



**JORDAN VALLEY WATER**  
CONSERVANCY DISTRICT

# 2024 VAULT IMPROVEMENT PROJECT

4390 S 2200 W, TAYLORSVILLE  
4330 S 300 W, MURRAY  
4500 S 350 E, MURRAY

11400 S 100 E, DRAPER  
11400 S 700 E, DRAPER

## VOLUME 2 - DRAWINGS

APRIL 2024 - JVVCD PROJECT # 4320

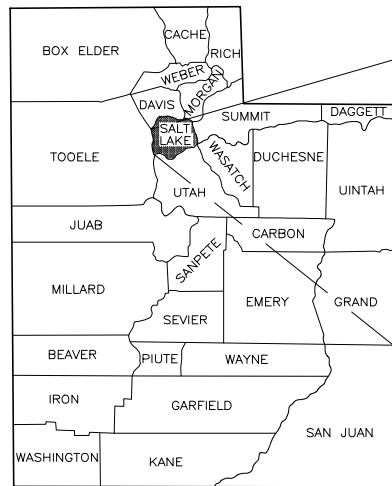

STATE OF UTAH

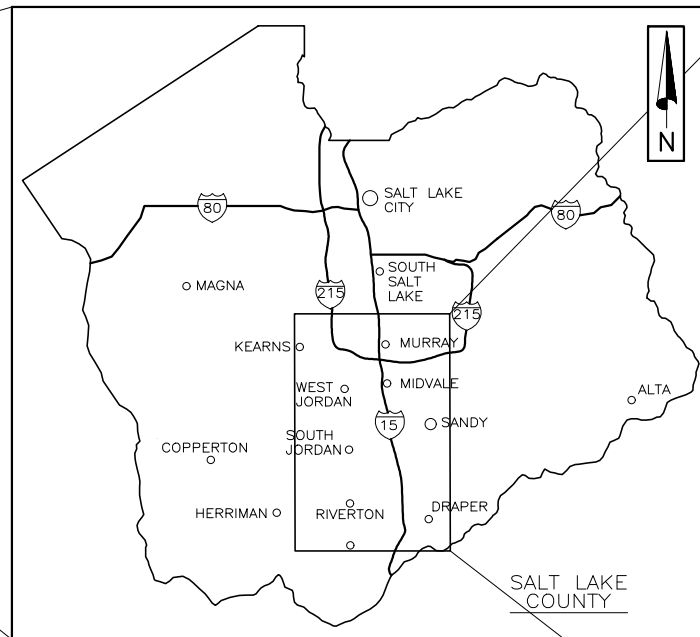

VICINITY MAP

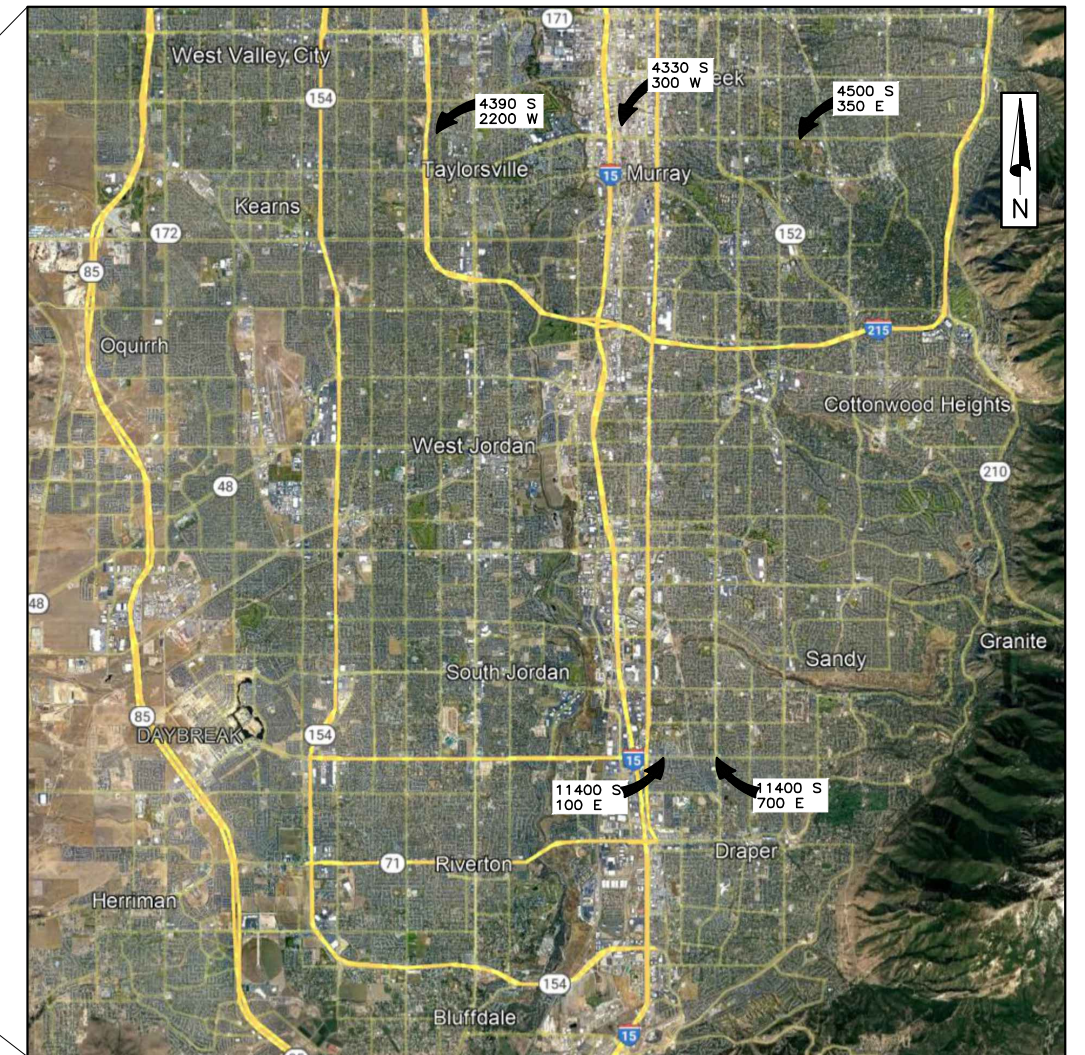

LOCATION MAP

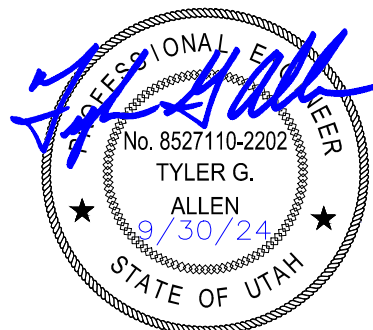
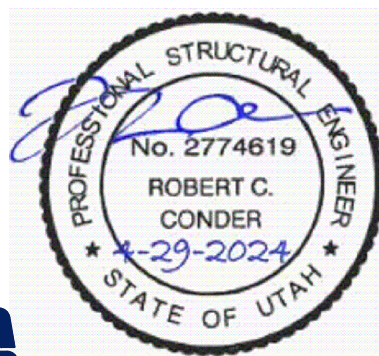

### HANSEN, ALLEN & LUCE DESIGN TEAM

TYLER G. ALLEN, P.E. — PRINCIPAL IN CHARGE  
NATHANIEL P. JONES, P.E. — PROJECT MANAGER





SECTION & DETAIL IDENTIFICATION

SECTION IDENTIFICATION

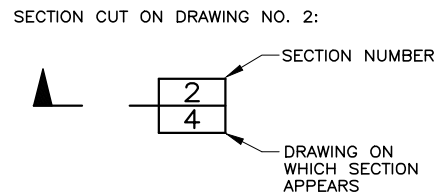

ON DRAWING NO. 4, THIS SECTION IS IDENTIFIED AS:

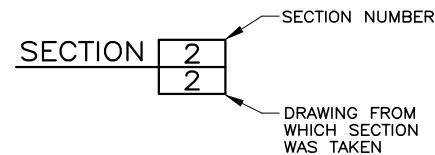

DETAIL IDENTIFICATION

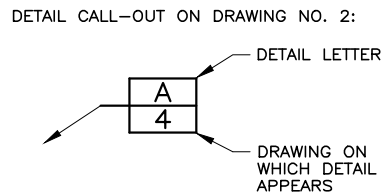

ON DRAWING NO. 4, THIS DETAIL IS IDENTIFIED AS:

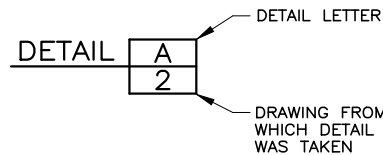

NOTES:

- IF SECTION CUT AND SECTION OR DETAIL CALL-OUT AND DETAIL ARE SHOWN ON SAME DRAWING, DRAWING NUMBER IS REPLACED BY A LINE.
- DETAIL LETTERS "I" AND "O" NOT USED.

LEGEND

— C-TV-UG —	— C-TV-UG —	EXISTING CABLE TV UNDER GROUND
— R D W —		EXISTING RIGHT-OF-WAY
— GS — GS — GS — GS — GS —		EXISTING GAS SERVICE LINE
— H P G —		EXISTING HIGH PRESSURE GAS LINE
— S S —		EXISTING SANITARY SEWER LINE
— S D —		EXISTING SANITARY STORM DRAIN
— W —		EXISTING WATER LINE
— P —		EXISTING POWER LINE
— T-UG — T-UG —		EXISTING TELEPHONE UNDER GROUND
— P-UG — P-UG — P-UG —		EXISTING UNDER GROUND POWER LINE
— F D —		EXISTING FIBER OPTIC LINE
— I R R —		EXISTING IRRIGATION LINE
— I R R —		EXISTING IRRIGATION LINE

	EXISTING VALVE
	EXISTING WATER METER
	EXISTING MANHOLE
	EXISTING LIGHT POLE
	EXISTING LIGHT POLE / TRAFFIC LIGHT
	EXISTING POLE W/ GUY WIRE

POTHoles

POTHOLE DETAIL SHEET (PHOTOS, DIMENSIONS, AND OTHER DATA) ARE IN SPEC SECTION 01 76 30 PROTECTION OF EXISTING FACILITIES. POTHOLE LOCATIONS ARE ALSO SHOWN ON THESE PLANS.

TABLE OF ABBREVIATIONS

⊙ = AT	DIP = DUCTILE IRON PIPE	PSI = POUND PER SQUARE INCH
AV = AIR VALVE	DWG = DRAWING	PVC = POLYVINYL CHLORIDE
AC = ASPHALT CONCRETE	ECC = ECCENTRIC	RJ = RESTRAINED JOINT
BFV = BUTTERFLY VALVE	EF = EACH FACE	SHT = SHEET
CC = CENTER TO CENTER	EL = ELEVATION	SS = STAINLESS STEEL
CL = CENTER LINE	EW = EACH WAY	STA = STATION
CLSM = CONTROLLED LOW STRENGTH MATERIAL (FLOW FILL)	FL = FLOW LINE	STL = STEEL
CML = CEMENT MORTAR LINED	FLG = FLANGE	SW = SOLVENT WELD
CMLC = CEMENT MORTAR LINED AND COATED	GE = GROOVED END	TB = THRUST BLOCK
CPLG = COUPLING	MAX = MAXIMUM	THD = THREAD
CTF = CUT TO FIT	MIN = MINIMUM	TYP = TYPICAL
CYL = CYLINDER	MJ = MECHANICAL JOINT	UBC = UNTREATED BASE COURSE
C&G = CURB & GUTTER	NTS = NOT TO SCALE	UNO = UNLESS NOTED OTHERWISE
DBL = DOUBLE	OC = ON CENTER	VTR = VENT THROUGH ROOF
DET = DETAIL	PE = PLAIN END	WSP = WELDED STEEL PIPE
DIA = DIAMETER		

TABLE NOTE: ABBREVIATIONS NOT LISTED IN THIS TABLE OR PLANS & SPECS ARE PER ASME Y1.1 (STANDARD ASME ABBREVIATIONS).



SEE SHEET C-1



SEE SHEETS C-2 & C-3



SEE SHEETS C-4, C-5, & C-6

INDEX OF DRAWINGS

SHEET NO.	TITLE	SHEET NO.	TITLE
<b>GENERAL</b>		<b>ELECTRICAL-GENERAL</b>	
G-1	COVER	E-1.1	LEGEND
G-2	LEGEND, PROJECT LOCATION & DRAWING INDEX	E-1.2	TABLES
G-3	GENERAL & CITY NOTES	E-1.3	COMMON DIAGRAMS
<b>CIVIL</b>		E-2.1	DETAILS, SH. 1
C-1	4390 S 2200 W SITE PLAN	E-2.2	NOT USED
C-2	4330 S 300 W SITE PLAN	E-2.3	DETAILS, SH. 3
C-3	4500 S 350 E SITE PLAN	E-3	NOT USED
C-4	11400 S STATE STREET SITE PLAN	<b>ELECTRICAL-JVWCD PS VAULT</b>	
C-4A	11400 S STATE STREET - 12" PIPE	<b>11400S 100E</b>	
C-5	11400 S 100 E SITE PLAN	E-4.1	SCHEDULES AND TABLES - 100E
C-6	11400 S 700 E SITE PLAN	E-4.4	SITE PLAN - 100E
C-7	4390 SOUTH 2200 WEST - VAULT	E-4.5	VAULT PLAN - 100E
C-8	4330 SOUTH 300 WEST - VAULT	<b>ELECTRICAL-WATER PRO VAULT</b>	
C-9	4500 SOUTH 350 EAST - VAULT	<b>11400S 700E</b>	
C-10	11400 SOUTH STATE STREET - VAULT	E-5.1	SCHEDULES AND TABLES - 700E
C-11	11400 SOUTH 100 EAST - PHOTOS	E-5.4	SITE PLAN - 700E
C-11A	NOT USED	E-5.5	VAULT PLAN - 700E
C-11B	11400 SOUTH 100 EAST - VAULT	<b>APPENDIX</b>	
C-12	11400 SOUTH 700 EAST - VAULT	<b>UDOT STANDARD REQUIREMENTS</b>	
C-13	TYPICAL DETAILS I	PV-0	UDOT STANDARD SPECS & DRAWINGS
C-14	TYPICAL DETAILS II	PV-1	JOINTS FOR HIGHWAYS WITH CONC TRAFFIC LANES AND SHOULDERS
C-15	TYPICAL DETAILS III	PV-2	CONC PAVEMENT DETAILS 1 OF 2
C-16	TYPICAL DETAILS IV	PV-3	CONC PAVEMENT DETAILS 2 OF 2
C-17	TYPICAL DETAILS V	PV-5	URBAN CONC PAVEMENT DETAILS
<b>CATHODIC PROTECTION</b>		PV-9	DOWEL BAR RETROFIT
CP-1	STANDARD DETAILS	PV-10	UTILITY ORIENTATION/ADJUSTMENT OPTIONS IN PCCP
CP-2	STANDARD DETAILS		
<b>STRUCTURAL</b>			
S-1	STRUCTURAL NOTES		
S-2	STRUCTURAL INSPECTIONS		
S-3	11400 SOUTH 100 EAST - VAULT ROOF		
S-4	11400 SOUTH 700 EAST - VAULT ROOF		
S-5	VAULT ROOF DETAILS		

FILE NAME: PROJECTS\127 - JVWCD\42.100 - 2023-24 VAULTS IMPROVEMENT\CAD\G-2 SHEET\_INDEX.DWG  
FILE DATE: 4.30.2024 09:50:46 (DD)



DESIGNED	NPJ	3
DRAFTED	DD	2
CHECKED	TGA	1
DATE	SEPTEMBER 2024	NO.

NO.	DATE	REVISIONS	BY	APVD.

SCALE  
NONE



2024 VAULT IMPROVEMENT PROJECT  
GENERAL  
LEGEND, PROJECT LOCATION & DRAWING INDEX

SHEET  
G-2  
127.42.100



**GENERAL NOTES**

- COMMAND TERMS (I.E. "PROVIDE", "CONSTRUCT", "INSTALL" ETC.) DESIGNATE WORK TO BE DONE BY CONTRACTOR.
- IN ADDITION TO THE TECHNICAL SPECIFICATIONS, DRAWINGS, AND OTHER PROVISIONS OR DOCUMENTS CONTAINED IN THESE CONTRACT DOCUMENTS; THESE DRAWINGS REFERENCE "MANUAL OF STANDARD SPECIFICATIONS" AND "MANUAL OF STANDARD PLANS" AS PREPARED BY THE UTAH CHAPTER OF THE AMERICAN PUBLIC WORKS ASSOCIATION AND THE ASSOCIATED GENERAL CONTRACTORS OF AMERICA, JWCD STANDARDS, AND CITY STANDARDS FOR THE VARIOUS JURISDICTIONAL MUNICIPALITIES / AGENCIES (LATEST EDITIONS) IN WHICH THIS PROJECT IS LOCATED (I.E. TAYLORSVILLE: 4390 S 2200 W; MURRAY: 4330 S 300 W; MURRAY / MILLCREEK: 4500 S 350 E; UDOT/SANDY/DRAPER: 11400 S STATE ST & 11400 S 700 E; SANDY/DRAPER: 11400 S 100 E). ANY CONFLICTS BETWEEN PROVISIONS OR DETAILS IN THE TECHNICAL SPECIFICATIONS, DRAWINGS, AND OTHER PROVISIONS OR DOCUMENTS CONTAINED IN THE CONTRACT DOCUMENTS VERSUS PROVISIONS CONTAINED IN THE LATEST EDITION OF APWA MANUAL OF STANDARD SPECIFICATIONS, APWA MANUAL OF STANDARD PLANS, JWCD STANDARDS, OR CITY STANDARDS SHALL BE RESOLVED IN FAVOR OF THE MOST STRINGENT OF THE CRITERIA AND CONDITIONS AS DETERMINED BY ENGINEER.
- CONTRACTOR SHALL MEET ALL UTAH STATE DEPARTMENT OF ENVIRONMENTAL QUALITY AND U.S. EPA REQUIREMENTS WITH RESPECT TO THEIR MINIMUM RULES AND REGULATIONS. ALL MATERIALS THAT MAY CONTACT DRINKING WATER, INCLUDING, PIPES, GASKETS, LUBRICANTS, O-RINGS, SHALL BE ANSI/NSF 61, DRINKING WATER SYSTEM COMPONENTS - HEALTH EFFECTS AND BE APPROPRIATELY STAMPED WITH THE NSF LOGO.
- CONSTRUCTION OPERATIONS SHALL BE CONDUCTED AND SIGNS, BARRICADES, AND FLASHERS SHALL BE PLACED SO AS TO COMPLY WITH OSHA, UTAH STATE INDUSTRIAL COMMISSION, LOCAL SAFETY STANDARDS, AND MANUAL ON UNIFORM TRAFFIC CONTROL.
- UTILITIES ARE SHOWN IN APPROXIMATE LOCATIONS. CONTRACTOR SHALL LOCATE ALL UNDERGROUND UTILITIES (WATER, FIBER, SEWER, TELEPHONE ETC.) AND ANY OTHER OBSTRUCTION DURING THE COURSE OF CONSTRUCTION. (CALL BLUE STAKES @ 1-800-662-4111)
- CONTRACTOR SHALL POTHOLE UTILITIES AT LEAST 2 DAYS AHEAD OF PIPELINE CONSTRUCTION TO VERIFY THAT THE DESIGN ALIGNMENT AND GRADE IS FEASIBLE AND TO PLAN ANY UTILITY RELOCATION'S THAT MAY BE NECESSARY. FAILURE TO POTHOLE IN ADVANCE WILL NOT RELIEVE THE CONTRACTOR FROM LOCATING THE PIPELINE IN AN ACCEPTABLE MANNER TO THE OWNER. ANY RELAYING OF THE PIPELINE, THAT MAY BECOME NECESSARY IN THIS REGARD, SHALL BE DONE AT THE CONTRACTORS EXPENSE.
- SUBMIT TO OWNER, CONTRACTOR AGREEMENTS WITH LAND OWNERS OF EACH PARCEL CONTRACTOR USES BEYOND PUBLIC STREET RIGHTS-OF-WAY AND OWNER EASEMENTS.
- UNLESS DETAILED, SPECIFIED OR INDICATED OTHERWISE, CONSTRUCTION SHALL BE AS INDICATED IN THE APPLICABLE TYPICAL DETAILS AND GENERAL NOTES. TYPICAL DETAILS ARE MEANT TO APPLY EVEN THOUGH NOT REFERENCED AT SPECIFIC LOCATIONS OR IN SPECIFIC DRAWINGS.
- CONTRACTOR SHALL BE RESPONSIBLE TO PROTECT ALL EXISTING IMPROVEMENTS DURING CONSTRUCTION AND SHALL REPLACE OR RESTORE ANY IMPROVEMENTS DAMAGED AS A RESULT OF THE CONSTRUCTION ACTIVITY, AS DIRECTED BY THE ENGINEER.
- CONTRACTOR SHALL VERIFY ALL DIMENSIONS BEFORE STARTING WORK AND SHALL IMMEDIATELY NOTIFY THE ENGINEER OF ANY DISCREPANCIES.
- THIS PROJECT IS LOCATED IN TAYLORSVILLE, MURRAY, MILLCREEK, SANDY, DRAPER CITY LIMITS AND UDOT ROADS. OBTAIN ALL APPLICABLE PERMITS AND APPROVALS FROM THESE RESPECTIVE ENTITIES AND COMPLY WITH THEIR RESPECTIVE REGULATIONS FOR TRAFFIC CONTROL, SAFETY, EXCAVATION IN PUBLICLY OWNED RIGHTS-OF-WAY, ETC.
- CONTRACTOR SHALL OBTAIN NOTICE OF INTENT, AND DEVELOP AND COMPLY WITH STORM WATER POLLUTION PREVENTION PLAN, AND ALL UPDES REQUIREMENTS.
- WORKING PRESSURE FOR THE INDIVIDUAL VAULTS AND SYSTEMS VARY. CONTRACTOR SHALL COORDINATE WITH JWCD TO OBTAIN CURRENT PRESSURES. ALL COMPONENTS FOR CONSTRUCTION SHALL BE MIN RATED FOR 250 PSI ON 4500 SOUTH PIPELINE & 300 PSI ON 11400 SOUTH PIPELINE.

**WATER NOTES**

- WATER LINE TRENCHES IN PRIVATE ROADWAYS OR TRAFFIC AREAS TO BE THOROUGHLY COMPACTED TO A MINIMUM OF 96% OF MAXIMUM DENSITY PER ASTM D1557. DENSITY CHECKS MAY BE REQUIRED BY THE GOVERNING JURISDICTION AT ANY TIME.
- A MINIMUM OF 48" OF COVER FROM THE TOP OF THE PIPE TO THE FINISH GRADE IS REQUIRED, EXCEPT AS NOTED.
- UNLESS OTHERWISE NOTED, ALL FITTINGS FOR PRESSURIZED WATER PIPING SHALL BE PROPERLY RESTRAINED BY THRUST BLOCKING, AND JOINT RESTRAINT.
- NEW MANHOLE RING & COVERS SHALL BE MARKED 'JWCD'.

**STEEL AND METAL FABRICATIONS:**

- BOLTS FOR PIPELINES: ASTM A193 BOLTS. IF BURIED, USE CARBON STEEL BOLTS, AWWA C217 WAX TAPE COATED.  
VAULTS: 316 SS BOLTS WITH GREASE CAPS (SILICONE RUBBER "MOCAP" FOR <2". USE SAP SEAL CAPS FOR >2")
- BOLTS FOR STRUCTURES: HIGH STRENGTH BOLTS CONFORMING TO THE FOLLOWING, EXCEPT WHERE SPECIFICALLY INDICATED OTHERWISE:  

UNLESS SHOWN OTHERWISE	A325-N
SLIP CRITICAL	A325-SC
ANCHOR BOLTS (AB)	
STAINLESS STEEL	F593, AISI TYPE 316, CONDITION CW
STEEL	F1554, GR 36
GALVANIZED STEEL	F1554, GR 36/A153
MACHINE BOLTS (MB)	A307

  - USE A307 BOLTS WITH PLATE WASHERS, UNLESS OTHERWISE SPECIFIED, FOR TYPICAL CONNECTIONS AND CONNECTIONS TO CONCRETE.
  - USE A325 BOLTS WITH PLATE WASHERS, UNLESS OTHERWISE SPECIFIED, FOR STEEL TO STEEL CONNECTIONS.
- ITEMS TO BE EMBEDDED IN CONCRETE SHALL BE CLEAN AND FREE OF OIL, DIRT AND PAINT.
- STEEL FABRICATED PARTS SHALL CONFORM THE CURRENT EDITION OF "THE AISC MANUAL OF STEEL CONSTRUCTION" AND CURRENT OSHA STANDARDS.
- ALL WELDS AND WELDING SHALL BE IN ACCORDANCE WITH AWS D1.1 OF "THE AMERICAN WELDING SOCIETY" (LATEST EDITION), USING ELECTRODES AS SPECIFIED THEREIN. WELDS TO BE MADE WITH E-70XX ELECTRODES U.N.O.
- EACH FIELD WELD SHALL HAVE A CWI INSPECTION REPORT STATING COMPLIANCE WITH AWS D1.1, A WPS FOR EACH WELD (OR SERIES OF LIKE WELDS), & PQR FOR EACH WELDER BY NAME.
- STEEL PIPE SHALL CONFORM TO A53, GRADE B AND HAVE 0.375 MIN WALL THICKNESS.

**GENERAL CONSTRUCTION NOTES**

- EXCAVATION, BEDDING AND BACKFILL FOR BURIED PIPELINES SHALL CONFORM TO CITY SPECIFIC STANDARDS, AND SECTION 31 23 15 OF THESE CONTRACT DOCUMENTS.
- ASPHALT, OR CONCRETE PAVEMENT CUTTING AND PATCHING SHALL CONFORM TO CITY SPECIFIC STANDARDS.
- CONTRACTOR SHALL REPLACE ANY EXISTING PAVEMENT, SIDEWALK OR CURB & GUTTER ALONG THE FRONTAGE OF THIS PROJECT, THAT IS DAMAGED OR REMOVED BY THE CONTRACTOR, OR AS DIRECTED BY CITY INSPECTORS OR ENGINEERS.
- ALL CONSTRUCTION SHALL CONFORM WITH THE CURRENT CITY STANDARD SPECIFICATIONS AND DETAILS FOR MUNICIPAL CONSTRUCTION FROM THE CITY IN WHICH CONSTRUCTION IS BEING CONDUCTED. (SEE NOTE 1 "GENERAL NOTES")
- ANY PROPOSED CHANGES TO THE APPROVED DESIGN SHALL BE REVIEWED AND APPROVED BY THE ENGINEER OF RECORD AND THE CITY ENGINEER.
- NOTIFY EACH CITY'S PUBLIC WORKS INSPECTION DEPARTMENT, 48 HOURS PRIOR TO BEGINNING CONSTRUCTION IN ANY ROADWAYS OR PUBLIC IMPROVEMENTS WITHIN CITY. ALL INSPECTIONS MUST BE DONE PRIOR TO OR CONCURRENT WITH CONSTRUCTION. FAILURE TO MAKE THIS NOTIFICATION MAY RESULT IN THE UNCOVERING AND/OR REMOVAL OF ALL CONSTRUCTION DONE WITHOUT NOTIFICATION AT THE DISCRETION OF CITY'S ENGINEER.
- PROVIDE A PROCTOR TEST FOR ANY ROADBASE MATERIAL, TO THE CITY'S PUBLIC WORKS INSPECTOR, WHEN DELIVERED OR PLACED ON SITE.
- DUST, MUD, AND EROSION SHALL BE ADEQUATELY CONTROLLED BY WHATEVER MEANS NECESSARY (EXCEPT AS NOTED), AND THE ROADWAYS SHALL BE KEPT FREE OF MUD AND DEBRIS AT ALL TIMES.
- THE USE OF MOTOR OILS AND OTHER PETROLEUM-BASED OR TOXIC LIQUIDS, FOR DUST SUPPRESSION, IS ABSOLUTELY PROHIBITED.
- PUBLIC NOTIFICATION TRAFFIC BOARDS SHALL BE PLACED AS PER CITY REQUIREMENT PRIOR TO CONSTRUCTION ON ALL AFFECTED ROADWAYS.
- TRAFFIC CONTROL PLANS SHALL BE SUBMITTED TO, AND APPROVED BY, THE APPROPRIATE CITY AGENCY PRIOR TO CONSTRUCTION (I.E. CITY, UDOT).

**OBSERVATION AND TESTING**

- SPECIAL INSPECTION DOES NOT INCLUDE OR WAIVE THE RESPONSIBILITY FOR ANY REQUIRED INSPECTIONS BY THE BUILDING OFFICIAL. THE CONTRACTOR IS RESPONSIBLE FOR SCHEDULING BOTH INSPECTIONS.
- SPECIFIED CONCRETE TESTING DURING CONSTRUCTION WILL BE CONTRACTOR SCHEDULED, OWNER AND ENGINEER APPROVED. SPECIFIED LAB TEST, MIXES AND SIMILAR TESTING TO VERIFY MATERIAL QUALITY AND CONFORMANCE TO THE SPECS, REQUIRING SUBMITTAL FOR REVIEW AND ACCEPTANCE, SHALL BE THE RESPONSIBILITY OF THE CONTRACTOR.
- STRUCTURAL OBSERVATIONS (CONTRACTOR SCHEDULED, OWNER AND ENGINEER APPROVED) IS REQUIRED IN ACCORDANCE WITH IBC SECTION 110 AND CHAPTER 17 AS INDICATED IN THE STATEMENT OF SPECIAL INSPECTION.

**CONSTRUCTION NOTES**

**FOR ALL CITIES AND SITES**

- OBTAIN RELEVANT PERMITS FROM JURISDICTIONAL AGENCIES, UDOT &/OR CITY. MAINTAIN DRIVEWAY ACCESS. NOTIFY ALL EMERGENCY SERVICES OF LOCATION & TIME OF EACH TRAFFIC LINE CLOSURE. IF WORK BLOCKS CROSSWALKS OR WALKS, PROVIDE ADA-COMPLIANT SIGNED DETOURS. PROVIDE ACCEPTABLE SIGNED DETOUR IF BIKE PATHS ARE BLOCKED.
- PROVIDE UDOT-APPROVED WATER FILLED BARRIERS (TRITON) PER MUTCD BETWEEN TRAFFIC & OPEN EXCAVATIONS. STEEL PLATE COVER TRENCHES DURING NON-CONSTRUCTION HOURS. ANCHOR STEEL PLATES TO PAVEMENT SO THEY DON'T SLIP.
- A. REPAIR ASPH. CONC: MATCH EXST THICKNESS + 1" (7" MAX THK IN UDOT HWYS). COMPLY WITH DET A, DWG C-13 (T-PATCH DETAIL). COMPLY WITH ALL JURISDICTIONAL AGENCY (UDOT/CITY) REQUIREMENTS AND STANDARDS. PAVE BETWEEN APRIL 15 AND OCT 31 (UNO). FOLLOW AGENCY WEATHER REQUIREMENTS.  
B. REPAIR CONC PAVEMENT (AT 700E): REPLACE FULL REINF. CONC PANELS PER UDOT STANDARDS, SPECS & PERMITS. USE UDOT RAPID STRENGTH CONC (BY PARSONS OR DRYCREEK - MIXED ONSITE, DRIES IN 1 HR, SPEC 03058). USE UDOT REINFORCING (RING BASKETS W/ L #11 BARS TIED W/ #5 BARS) PREMADE.
- RESTORE EXISTING LANE MARKINGS AFTER PAVING. RESTORE EXISTING FACILITIES DISTURBED (IE WALKS, C&G, LANDSCAPING, UTILITIES, SURFACE FEATURES, ETC).
- COORDINATE WORK TIMING AND JWCD MAINS SHUTDOWNS PER NOTES IN DWGS C-1 THRU C-8.  
A. WATER SHUTDOWNS FOR THE 4390S 2200W, 4500S 350E, 11400S 100E, 11400S 700E VAULTS SHALL BE BETWEEN OCT 15 AND MAR 15.  
B. WORK AT THE 4330S 300W VAULT MAY BE COMPLETED AT ANY TIME OF YEAR
- ALL NEW WATER MAINS SHALL BE "RJ" UNO. "RJ" MEANS "RESTRAIN ALL JOINTS" (INCLUDES JOINTS TO EXST PIPE).

**TAYLORSVILLE CITY:** 4390 S 2200 W CONTACT: BEN WHITE 801-293-8344

- OBTAIN, PAY AND COMPLY WITH CITY PERMIT. SUBMIT & GET CITY APPROVAL FOR TRAFFIC CONTROL PLAN. 1-LANE FLAGGED TRAFFIC IS ALLOWED FROM 9AM TO 3PM. MAINTAIN 2-WAY TRAFFIC (12' LINES) AT OTHER TIMES. SEE SPECS AND SHEET C-1 REQUIREMENTS.
- AMBIENT TEMPERATURE MUST BE 50 DEG F & RISING FOR PERMANENT HOT MIX ASPHALT PAVING.

**MURRAY CITY:** 4330 S 300 W (COMMERCE AVE) CONTACT: TRAE STOKES 801-270-2440

- PREPARE, SUBMIT AND EDIT CONTRACTOR TRAFFIC CONTROL PLAN UNTIL APPROVED BY MURRAY. NO ROAD CLOSURES ARE PERMITTED. MAINTAIN 1-LANE THRU TRAFFIC IN BOTH DIRECTIONS UNO. UDOT HAS NO REQUIREMENTS AT THIS SITE.
- PAVING IS PER MURRAY CITY PERMIT REQUIREMENTS.

**MURRAY/MILLCREEK:** 4500 S 350 E MURRAY CONTACT: TRAE STOKES 801-270-2440  
MILLCREEK CONTACT: AARON ROBERTS 801-214-2662

- PREPARE, SUBMIT AND EDIT CONTRACTOR TRAFFIC CONTROL PLAN UNTIL APPROVED BY MURRAY, MILLCREEK & UDOT. NO ROAD CLOSURES ARE PERMITTED. MAINTAIN THRU TRAFFIC IN BOTH DIRECTIONS UNO. SEE SHEET C-2 REQUIREMENTS.
- UDOT REQUIRES WORK BE DONE BETWEEN 9AM TO 3PM. MAINTAIN 1-LANE TRAFFIC IN BOTH DIRECTIONS. COMPLY WITH UDOT STANDARDS. PROVIDE SIGNS IN BOTH DIRECTIONS 72 HOURS BEFORE WORK UNTIL END. KEEP ALL WORK IN MEDIAN OR THE FIRST LANE SOUTH OF MEDIAN.

**11400 S:** SEE SHEETS C-5, C-6 & PV-0.

UDOT CONTACT: PETER TANG 801-887-3459; EMAIL: ptang@utah.gov  
SANDY CONTACT: BRITTANY WARD, SANDY TRAFFIC ENGINEER, 801-568-2991.  
DRAPER CONTACT: BRIEN MAXFIELD, SENIOR ENGINEER MANAGER, 801-576-6326.

- OBTAIN AND COMPLY WITH UDOT PERMITS. DRAPER + SANDY PERMITS AT 100 E VAULT. SUBMIT & EDIT CONTRACTOR TRAFFIC CONTROL PLANS UNTIL APPROVED BY ALL JURISDICTIONAL AGENCIES.
- PROVIDE VARIABLE MESSAGE SIGNS (VMS) ON ALL APPROACHES TO WORK (72 HOURS BEFORE WORK UNTIL AFTER WORK IS DONE), INFORMING PUBLIC OF FUTURE CONSTRUCTION AND CHANGES IN TRAFFIC PATTERNS.
- 100 E REQUIREMENTS (SEE SHEET C-5):** DRAPER-SANDY CITY BOUNDARY IS AT CENTER OF 11400 S STREET (100E IS NOT UDOT CONTROLLED). DRAPER WILL ISSUE PERMIT & REVIEW CONTRACTOR TRAFFIC CONTROL. ALSO, SUBMIT TRAFFIC CONTROL TO SANDY (BRITNEY WARD) AND INTEGRATE SANDY INPUT.

**700E UDOT REQUIREMENTS (SEE SHEET C-6):**

- 700E, SHT C-6. KEEP ALL LANES OPEN IN NON-WORK HOURS (FLUSH PLANTING):  
- BUILD AT NIGHT 9PM TO 5AM (COMPLY W/ NOISE ORDINANCE) OR DURING DAY (9AM TO 3PM).
- CALL UDOT BEFORE CONSTRUCTION TO MARK UDOT SIGNAL COMMUNICATION FIBERS IN PAVEMENT - LOCATIONS UNKNOWN. REMOVE/REPLACE (FUNCTIONAL) ALL UDOT SIGNAL FIBERS IN PAVEMENT.
- USE UDOT RAPID SET CLSM (TRENCH ZONE) & CONC (FULL CONC PANELS & UDOT REBAR BASKETS/DOWELS PER UDOT STD SPECS & DWGS SEE PV-0).
- INSULATE & CURE CONCRETE ABOVE 40 DEG F, SEE SPECS ON SHEET PV-0.

FILE NAME: PROJECTS\127 - JWCD\42.100 - 2023-24 VAULTS IMPROVEMENT\CAD\G-3 GENERAL\_CITY NOTES\_R2\_REWORK.DWG  
FILE DATE: 9/30/2024 11:57:47 (DD)



DESIGNED	NPJ	3	
DRAFTED	DD	2	
CHECKED	TGA	1	
DATE	SEPTEMBER 2024	NO.	DATE

NO.	DATE	REVISIONS	BY	APVD.

SCALE  
NONE



2024 VAULT IMPROVEMENT PROJECT  
GENERAL  
GENERAL & CITY NOTES

SHEET  
G-3  
127.42.100



FILE NAME: PROJECTS\127\_JVWCD\42.100 - 2023-24 VAULTS IMPROVEMENT\CAD\C-1 SITE PLAN 4390S\_2200W\_1.DWG  
 FILE DATE: 9/30/2024 11:51:15 (DD)

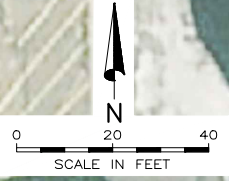
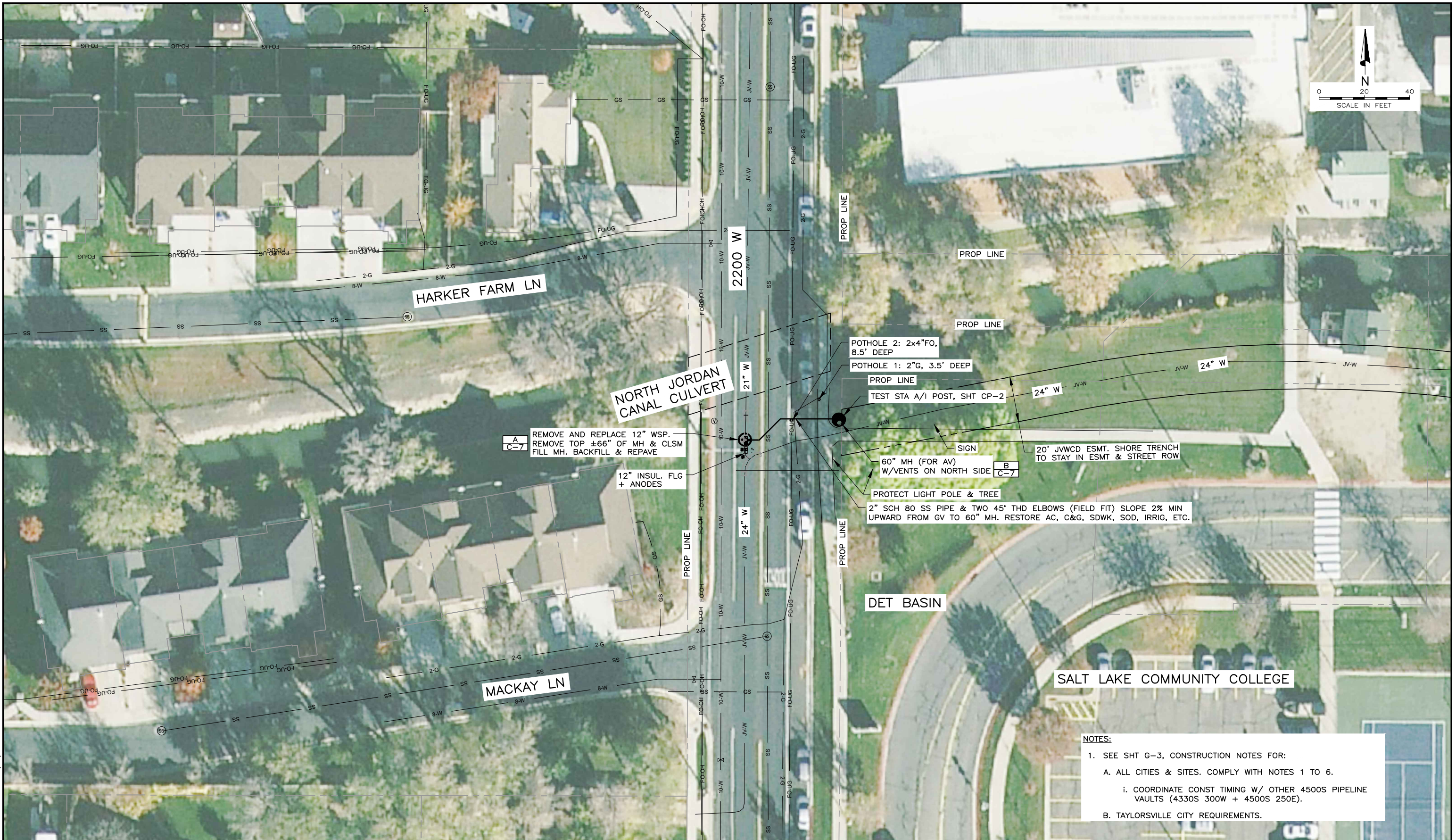

**SITE PLAN**

**NOTES:**

1. SEE SHT G-3, CONSTRUCTION NOTES FOR:
  - A. ALL CITIES & SITES. COMPLY WITH NOTES 1 TO 6.
    - i. COORDINATE CONST TIMING W/ OTHER 4500S PIPELINE VAULTS (4330S 300W + 4500S 250E).
  - B. TAYLORSVILLE CITY REQUIREMENTS.



DESIGNED	NPJ	3
DRAFTED	DD	2
CHECKED	TGA	1
DATE	SEPTEMBER 2024	NO.

NO.	DATE	REVISIONS	BY	APVD.

SCALE  
AS SHOWN



2024 VAULT IMPROVEMENT PROJECT  
 CIVIL  
 4390 S 2200 W SITE PLAN

SHEET  
C-1  
127.42.100



FILE NAME: PROJECTS\127\_JVWCD\42.100 - 2023-24 VAULTS IMPROVEMENT\CAD\C-2 SITE PLAN 4500S\_300W\_1.DWG  
 FILE DATE: 9/30/2024 11:52:35 (DD)

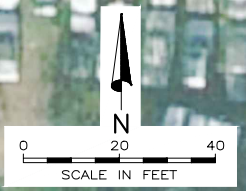
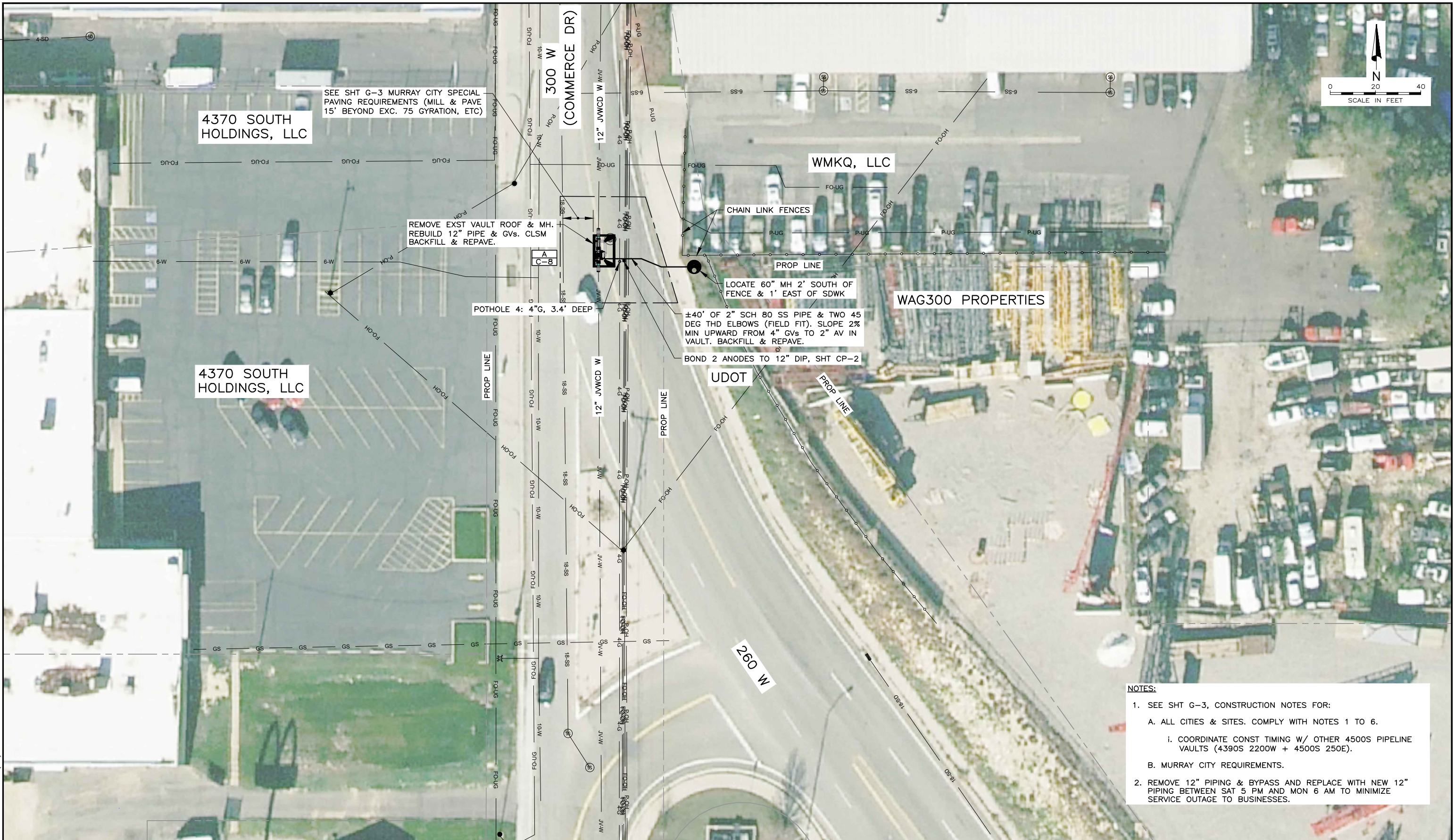

**NOTES:**

1. SEE SHT G-3, CONSTRUCTION NOTES FOR:
  - A. ALL CITIES & SITES. COMPLY WITH NOTES 1 TO 6.
    - i. COORDINATE CONST TIMING W/ OTHER 4500S PIPELINE VAULTS (4390S 2200W + 4500S 250E).
  - B. MURRAY CITY REQUIREMENTS.
2. REMOVE 12" PIPING & BYPASS AND REPLACE WITH NEW 12" PIPING BETWEEN SAT 5 PM AND MON 6 AM TO MINIMIZE SERVICE OUTAGE TO BUSINESSES.

**SITE PLAN**

7/04



DESIGNED	NPJ	3
DRAFTED	DD	2
CHECKED	TGA	1
DATE	SEPTEMBER 2024	NO.

NO.	DATE	REVISIONS	BY	APVD.

SCALE AS SHOWN



2024 VAULT IMPROVEMENT PROJECT  
 CIVIL  
 4330 S 300 W SITE PLAN

SHEET C-2  
 127.42.100



FILE NAME: PROJECTS\127\_JVWCD\42.100 - 2023-24 VAULTS IMPROVEMENT\CAD\C-3 SITE PLAN 4500S\_350E\_1.DWG  
 FILE DATE: 9/30/2024 11:32:58 (DD)

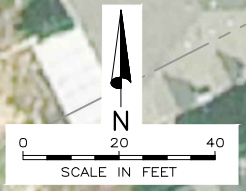
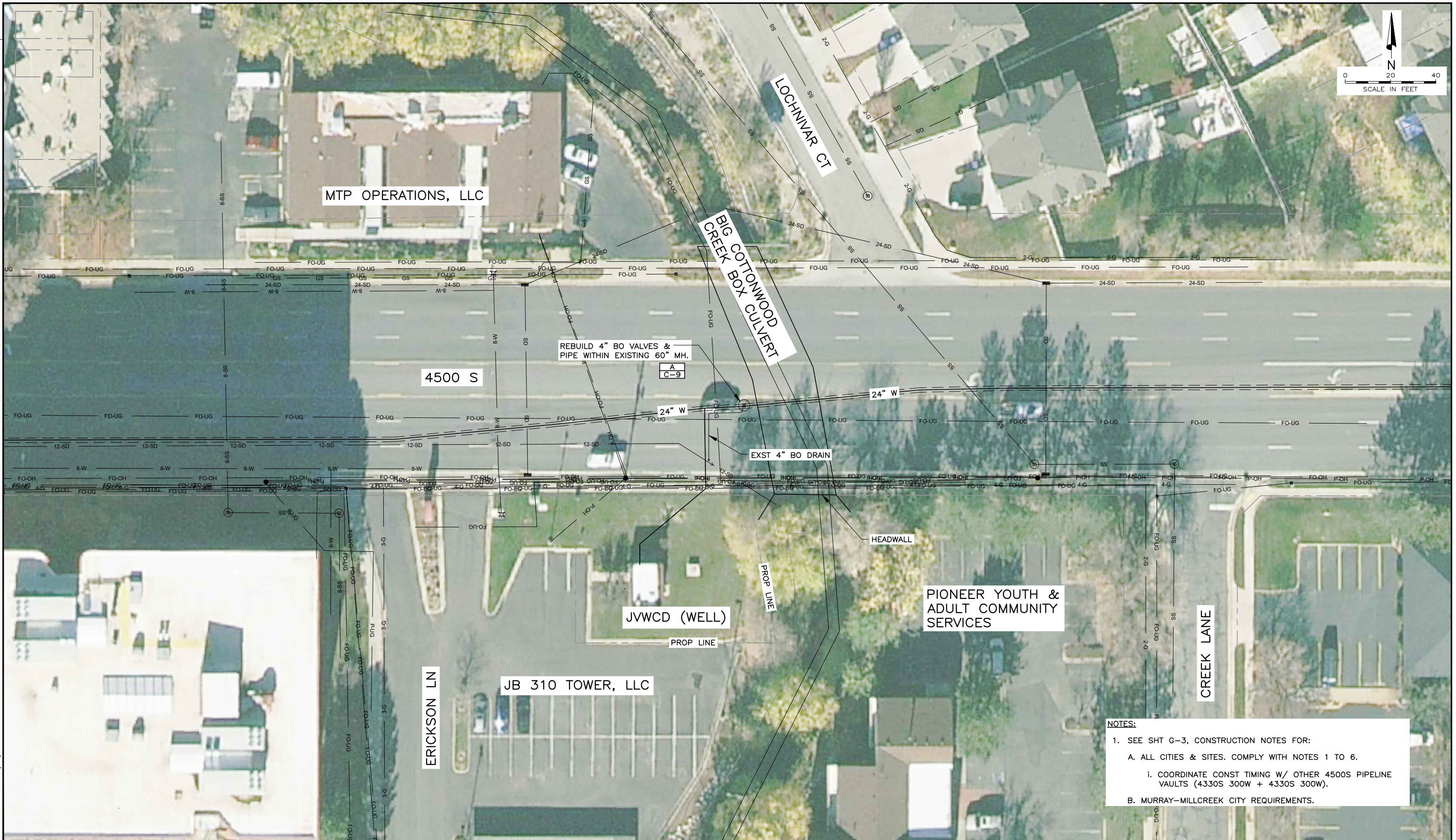

**NOTES:**

1. SEE SHIT G-3, CONSTRUCTION NOTES FOR:
  - A. ALL CITIES & SITES. COMPLY WITH NOTES 1 TO 6.
    - i. COORDINATE CONST TIMING W/ OTHER 4500S PIPELINE VAULTS (4330S 300W + 4330S 300W).
  - B. MURRAY-MILLCREEK CITY REQUIREMENTS.

**SITE PLAN**

7/04



DESIGNED	NPJ	3
DRAFTED	DD	2
CHECKED	TGA	1
DATE	SEPTEMBER 2024	NO.

NO.	DATE	REVISIONS	BY	APVD.

SCALE  
AS SHOWN



2024 VAULT IMPROVEMENT PROJECT  
 CIVIL  
 4500 S 350 E SITE PLAN

SHEET  
C-3  
127.42.100



FILE NAME: PROJECTS\127 - JWCD\42.100 - 2023-24 VAULTS IMPROVEMENT\CAD\C-5 SITE PLAN 11400S\_100E\_2\_REWORK.DWG  
 FILE DATE: 9/30/2024 11:41:43 (DD)

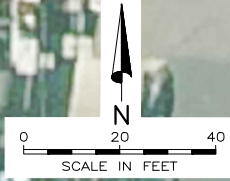
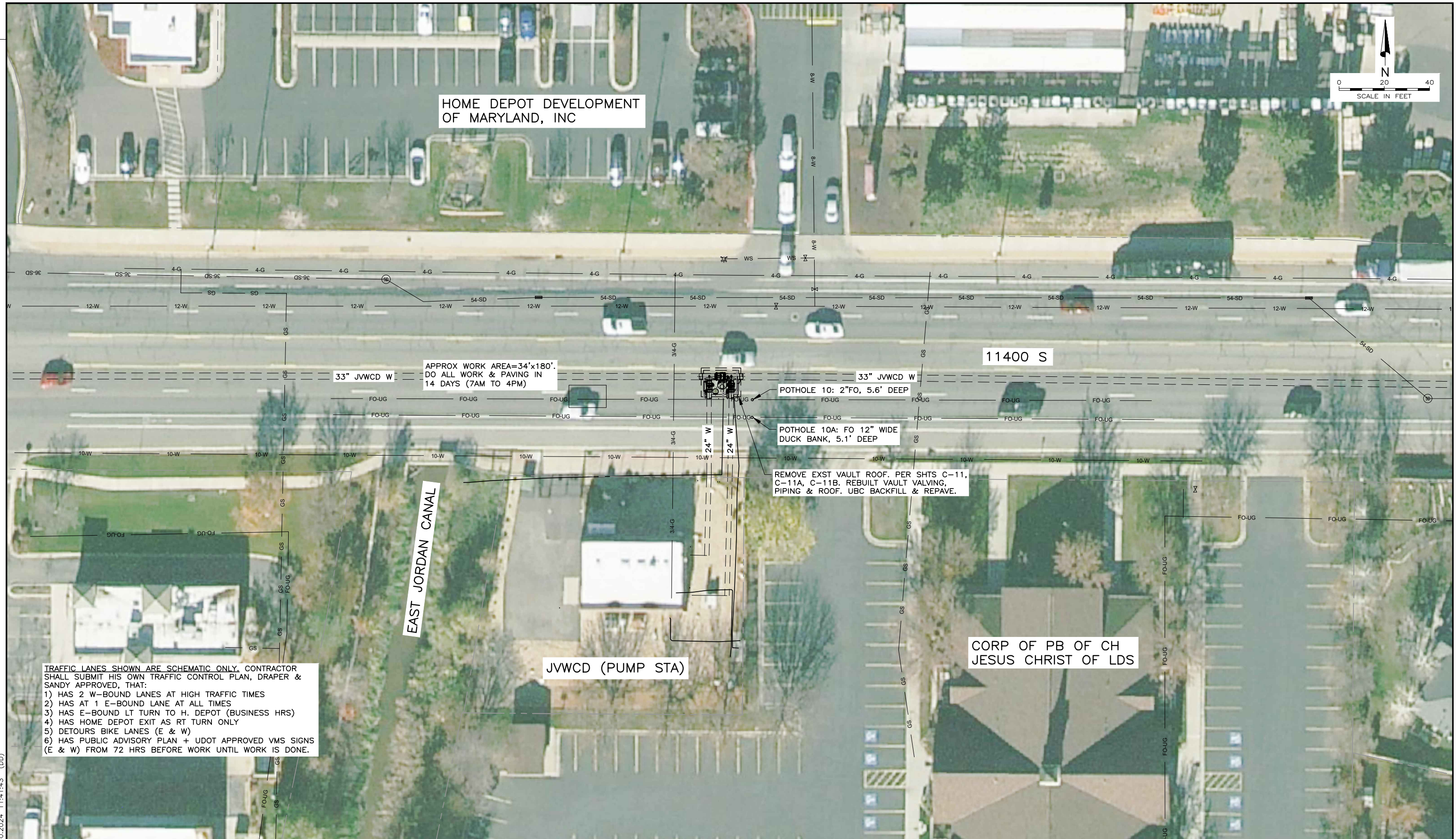

SITE PLAN



DESIGNED NPJ 3  
 DRAFTED DD 2  
 CHECKED TGA 1  
 DATE SEPTEMBER 2024 NO. DATE

NO.	DATE	REVISIONS	BY	APVD.

SCALE AS SHOWN



2024 VAULT IMPROVEMENT PROJECT  
 CIVIL  
 11400 S 100 E SITE PLAN

SHEET C-5  
 127.42.100



FILE NAME: PROJECTS\127\_JVWCD\42.100 - 2023-24 VAULTS IMPROVEMENT\CAD\C-6 SITE PLAN 11400S\_700E\_RT\_REWORK.DWG  
 FILE DATE: 9/30/2024 11:50:48 (DD)

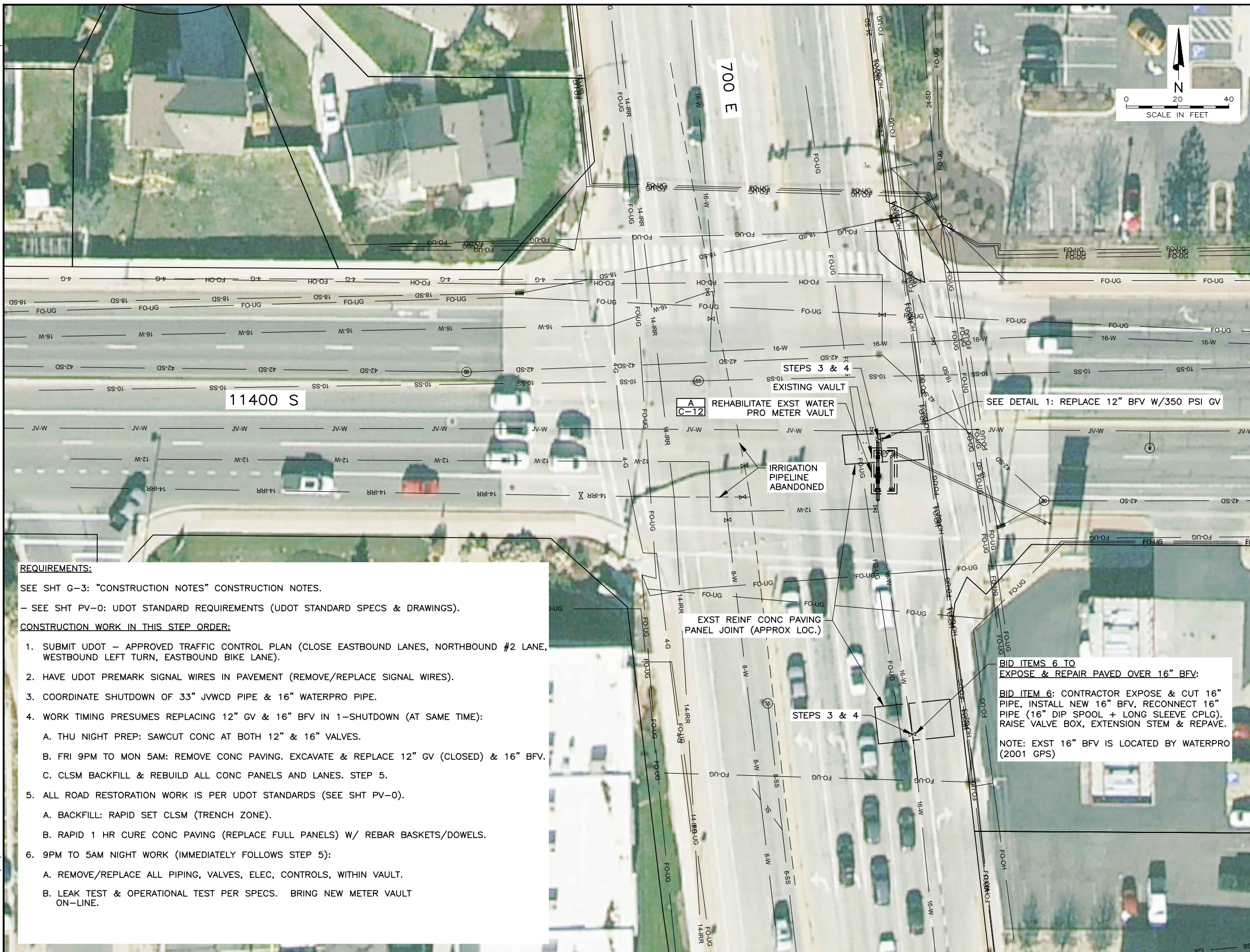

**REQUIREMENTS:**

SEE SHT G-3: "CONSTRUCTION NOTES" CONSTRUCTION NOTES.  
 - SEE SHT PV-0: UDOT STANDARD REQUIREMENTS (UDOT STANDARD SPECS & DRAWINGS).

**CONSTRUCTION WORK IN THIS STEP ORDER:**

1. SUBMIT UDOT - APPROVED TRAFFIC CONTROL PLAN (CLOSE EASTBOUND LANES, NORTHBOUND #2 LANE, WESTBOUND LEFT TURN, EASTBOUND BIKE LANE).
2. HAVE UDOT PREMARK SIGNAL WIRES IN PAVEMENT (REMOVE/REPLACE SIGNAL WIRES).
3. COORDINATE SHUTDOWN OF 33" JVWCD PIPE & 16" WATERPRO PIPE.
4. WORK TIMING PRESUMES REPLACING 12" GV & 16" BFV IN 1-SHUTDOWN (AT SAME TIME):
  - A. THU NIGHT PREP: SAWCUT CONC AT BOTH 12" & 16" VALVES.
  - B. FRI 9PM TO MON 5AM: REMOVE CONC PAVING. EXCAVATE & REPLACE 12" GV (CLOSED) & 16" BFV.
  - C. CLSM BACKFILL & REBUILD ALL CONC PANELS AND LANES. STEP 5.
5. ALL ROAD RESTORATION WORK IS PER UDOT STANDARDS (SEE SHT PV-0).
  - A. BACKFILL: RAPID SET CLSM (TRENCH ZONE).
  - B. RAPID 1 HR CURE CONC PAVING (REPLACE FULL PANELS) W/ REBAR BASKETS/DOWELS.
6. 9PM TO 5AM NIGHT WORK (IMMEDIATELY FOLLOWS STEP 5):
  - A. REMOVE/REPLACE ALL PIPING, VALVES, ELEC, CONTROLS, WITHIN VAULT.
  - B. LEAK TEST & OPERATIONAL TEST PER SPECS. BRING NEW METER VAULT ON-LINE.

**A  
C-12**  
 REHABILITATE EXIST WATER  
 PRO METER VAULT

IRRIGATION  
 PIPELINE  
 ABANDONED

EXIST REINF CONC PAVING  
 PANEL JOINT (APPROX LOC.)

**BID ITEMS 6 TO**  
 EXPOSE & REPAIR PAVED OVER 16" BFV:

**BID ITEM 6:** CONTRACTOR EXPOSE & CUT 16" PIPE, INSTALL NEW 16" BFV, RECONNECT 16" PIPE (16" DIP SPOOL + LONG SLEEVE CPLG). RAISE VALVE BOX, EXTENSION STEM & REPAVE.

NOTE: EXIST 16" BFV IS LOCATED BY WATERPRO (2001 GPS)

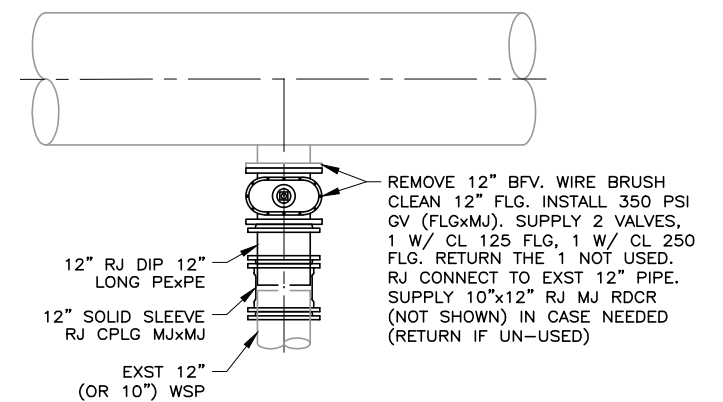

**DETAIL 1 - CUT IN 12" GV**

**NOTES:**

1. DBL BOND ALL BURIED JOINTS PER SHT CP-1.
2. RESTRAIN ALL JOINTS. USE CLASS 53 DIP.
3. WAX TAPE COAT (NOT SHOWN) ALL VALVES & JOINTS (TO 6" BEYOND BOLTS).
4. OMIT CONC UNDER GATE VALVE. COMPACT GRANULAR PIPE ZONE TO 97%.
5. INSTALL VALVE BOX + EXT STEM. RAPID SET CLSM BACKFILL TO RD SUBGRADE.

**SITE PLAN**



DESIGNED	NPJ	3
DRAFTED	DD	2
CHECKED	TGA	1
DATE	SEPTEMBER 2024	NO.

NO.	DATE	REVISIONS	BY	APVD.

SCALE  
 AS SHOWN



2024 VAULT IMPROVEMENT PROJECT  
 CIVIL  
 11400 S 700 E SITE PLAN

SHEET  
 C-6

127.42.100



FILE NAME: PROJECTS\127 - J\WCD\42.100 - 2023-24 VAULTS IMPROVEMENT\CAD\C-7 VAULT 4390S\_2200W.DWG  
 FILE DATE: 9/30/2024 11:51:13 (DD)

7/04

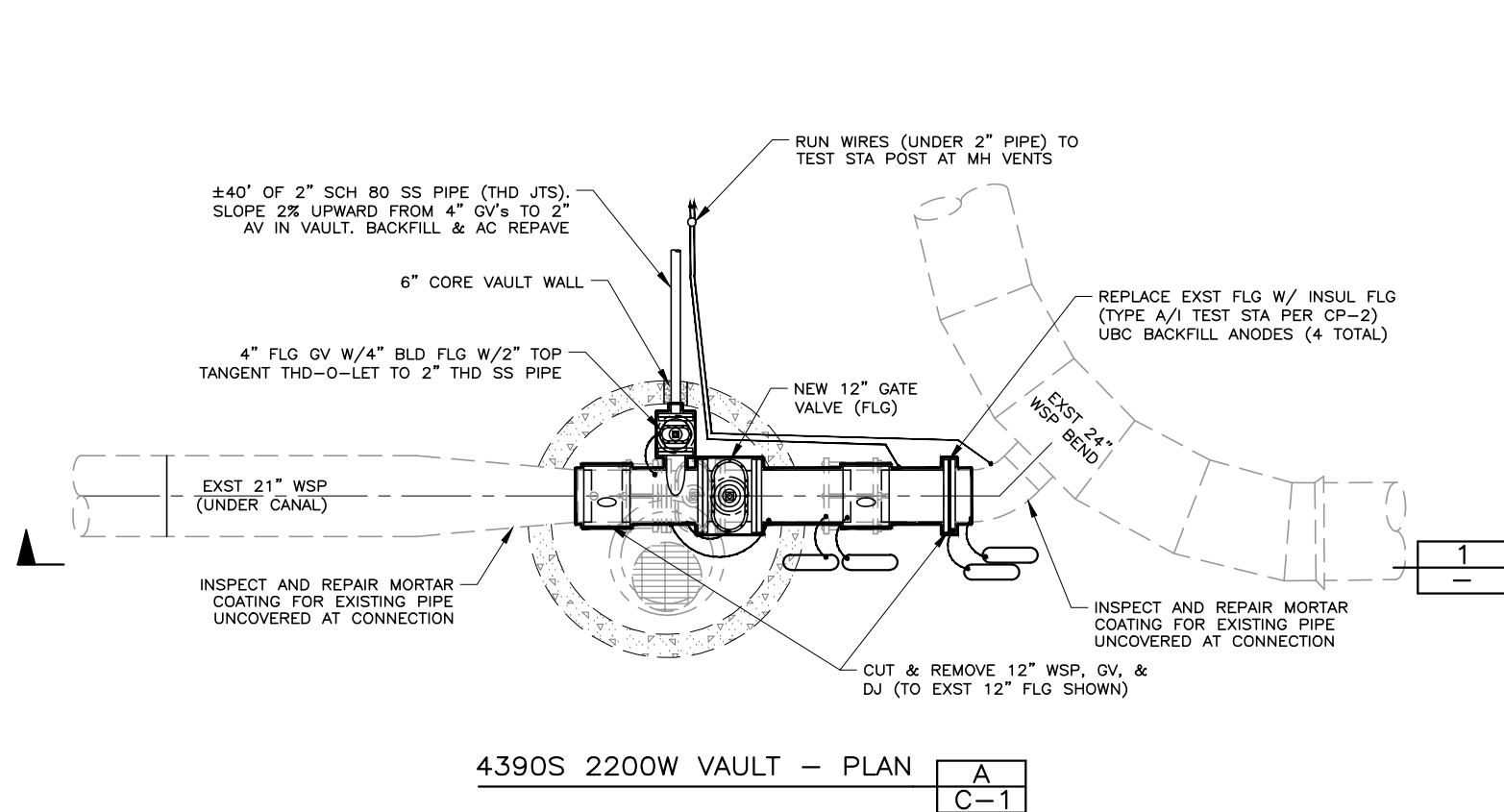

4390S 2200W VAULT - PLAN  
 A  
 C-1

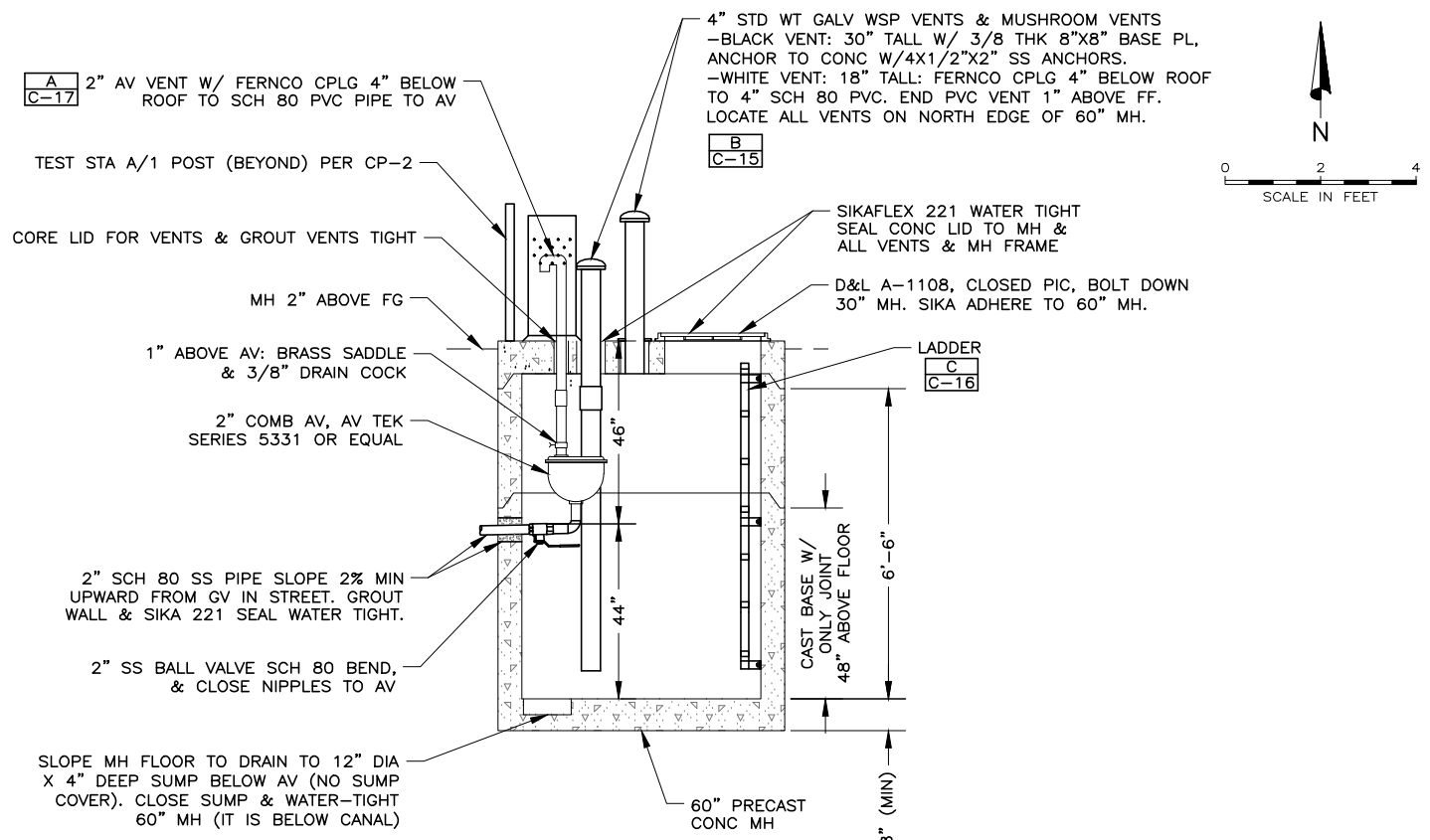

AV MH DETAIL  
 B  
 C-1

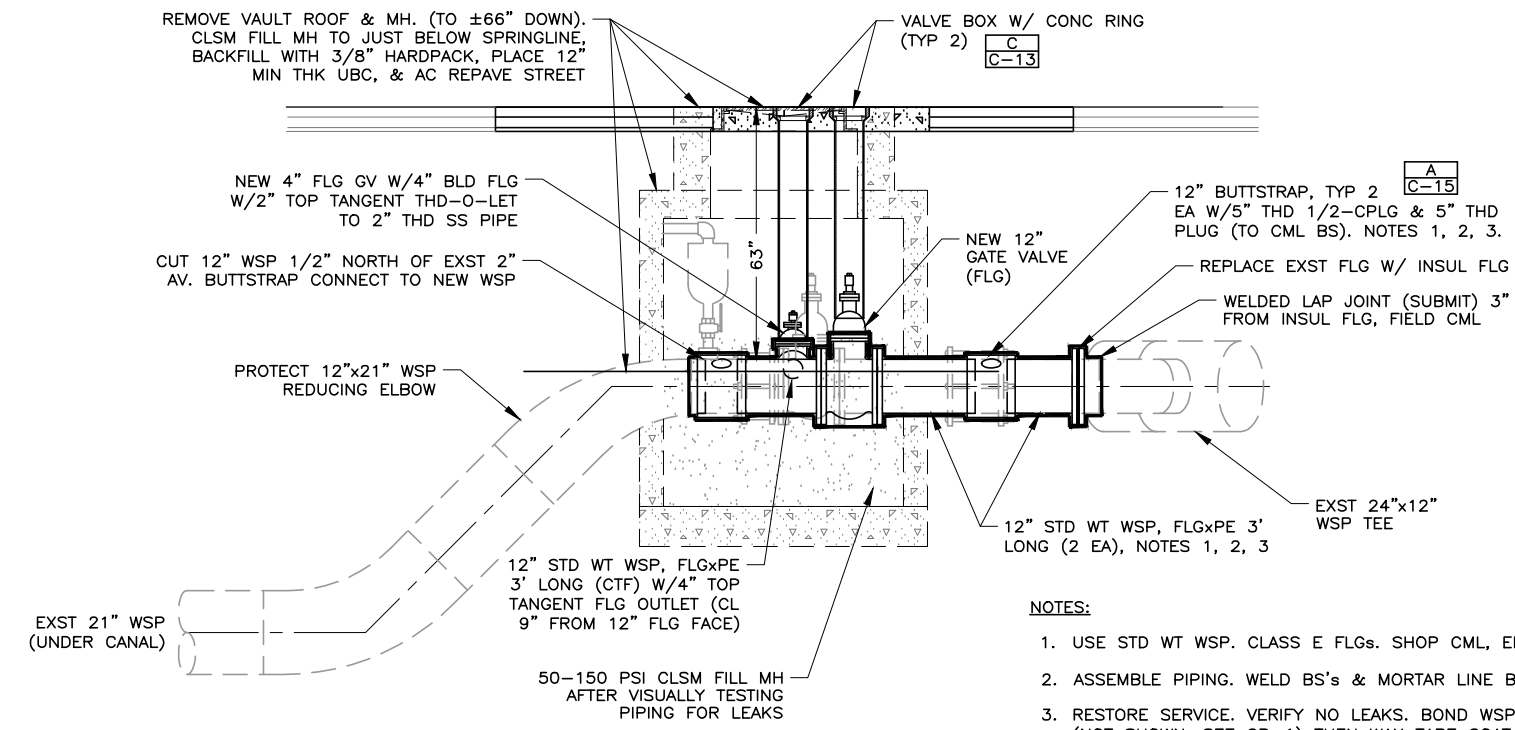

4390S 2200W VAULT - SECTION  
 1  
 -

- NOTES:
1. USE STD WT WSP. CLASS E FLGS. SHOP CML, EPOXY COAT.
  2. ASSEMBLE PIPING. WELD BS's & MORTAR LINE BS PER SPEC.
  3. RESTORE SERVICE. VERIFY NO LEAKS. BOND WSP & VALVES (NOT SHOWN, SEE CP-1) THEN WAX TAPE COAT ALL 12" PIPING & ALL PIPING WITHIN AREA OF 60" MH BASE.

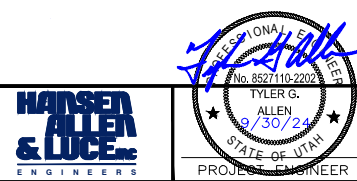
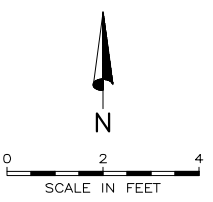

DESIGNED	NPJ	3
DRAFTED	DD	2
CHECKED	TGA	1
DATE	SEPTEMBER 2024	

NO.	DATE	REVISIONS	BY	APVD.

SCALE  
 AS SHOWN



2024 VAULT IMPROVEMENT PROJECT  
 CIVIL  
 4390 SOUTH 2200 WEST - VAULT

SHEET  
 C-7  
 127.42.100



FILE NAME: PROJECTS\127 - JWCD\42.100 - 2023-24 VAULTS IMPROVEMENT\CAD\C-8 VAULT 4330S\_300W\_R1.DWG  
 FILE DATE: 9/30/2024 13:49:41 (DD)

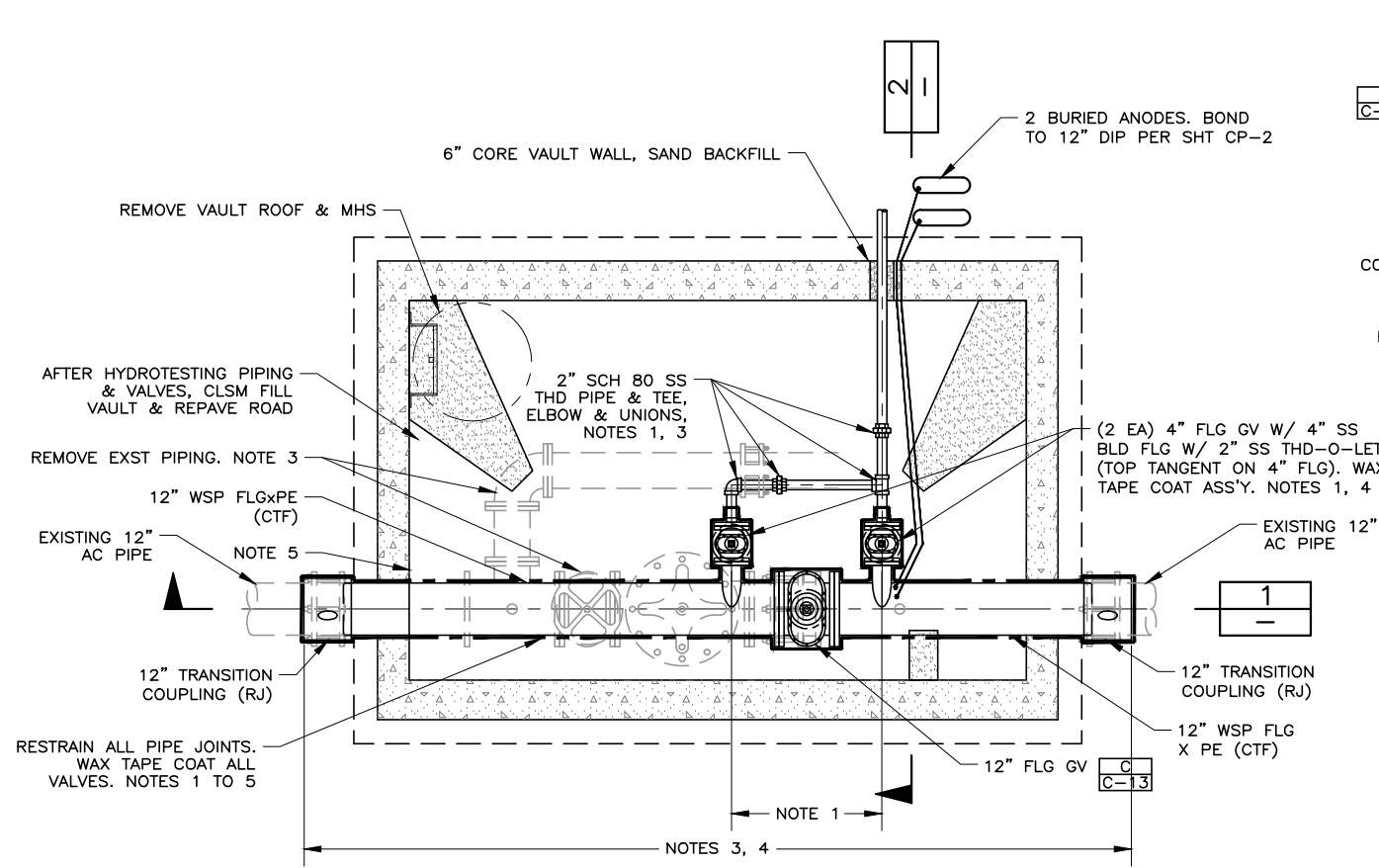

4330 SOUTH 300 WEST - PLAN

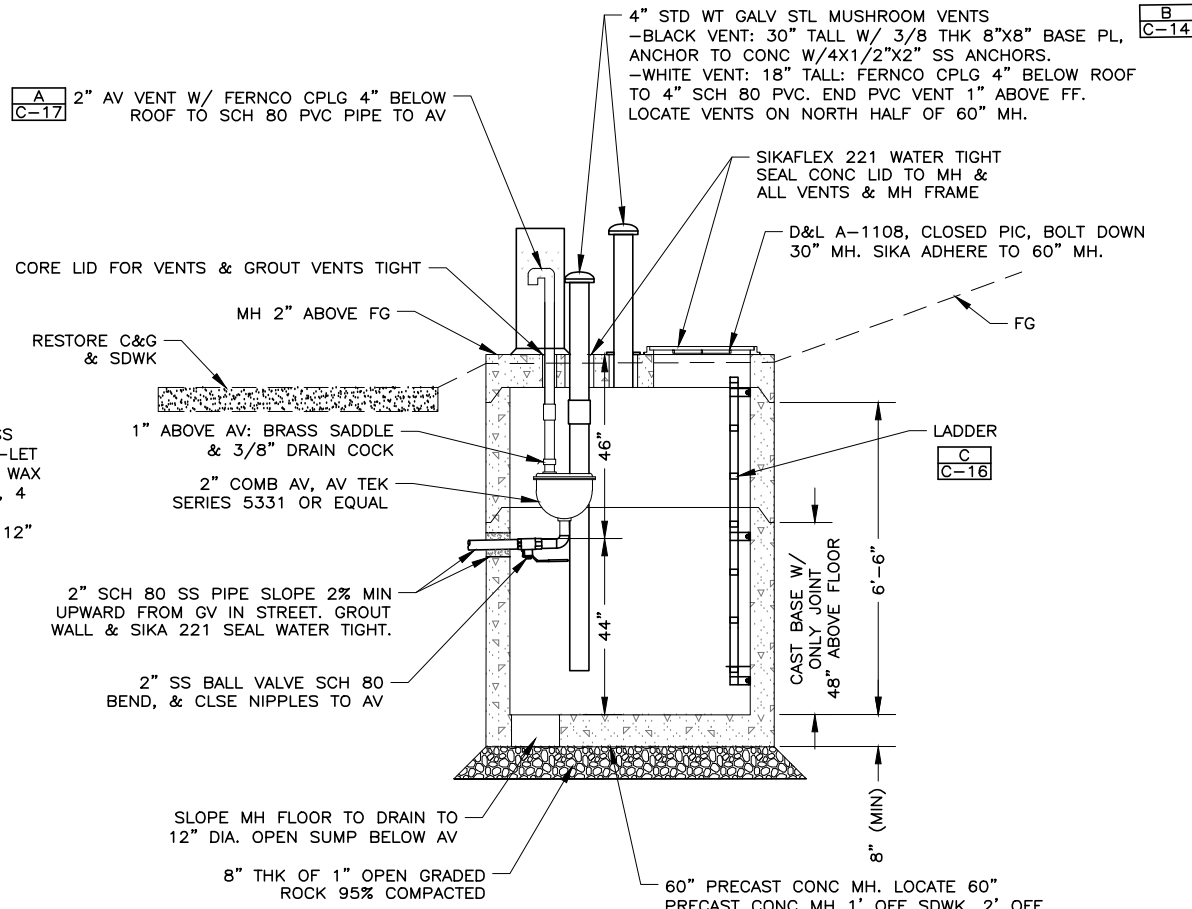

AV MH DETAIL

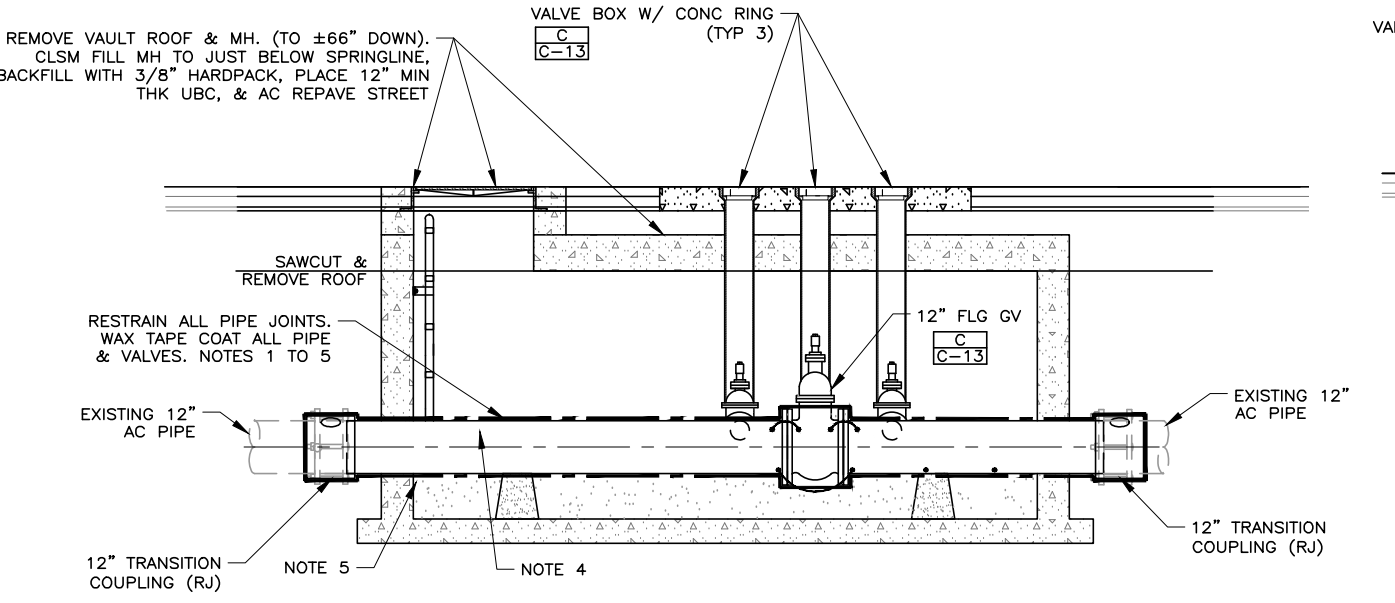

4330 SOUTH 300 WEST - SECTION 1

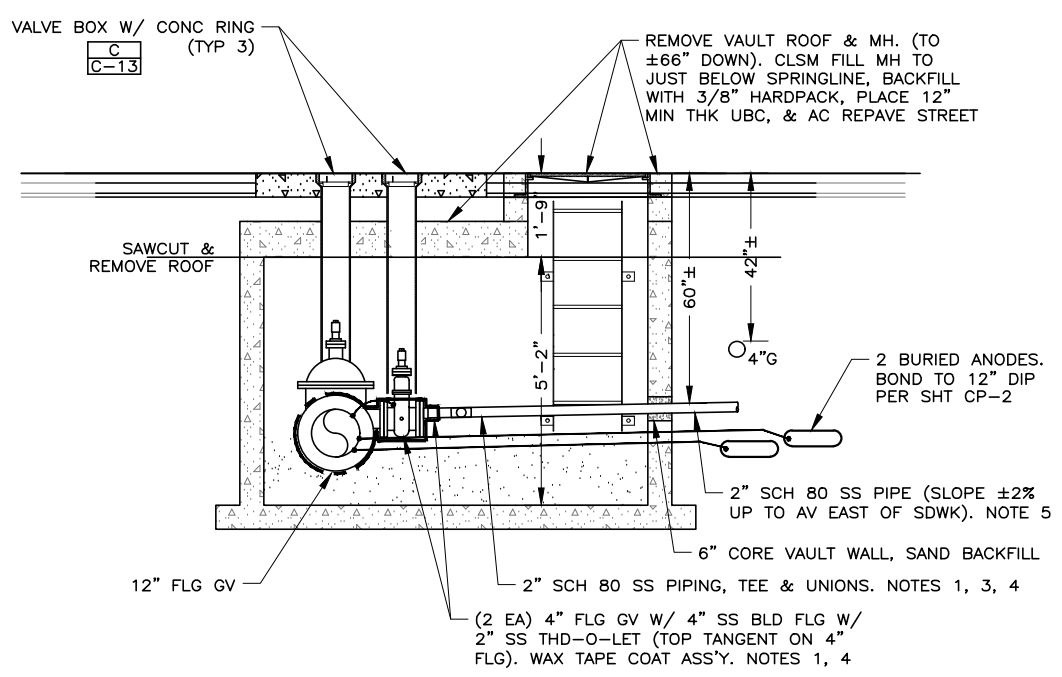

4330 SOUTH 300 WEST - SECTION 2

- NOTES (DO WORK IN THIS ORDER):**
1. SHOP ASSEMBLE PIPING LOOP (4" GVs + 2" SS PIPE LOOP). LEAK TEST ALL GVs & PIPING ARE DRIP TIGHT, THEN OPEN 12" GV & SHUT 4" GVs.
  2. SAWCUT & REMOVE VAULT AS DETAILED. TO MINIMIZE 12" MAIN SHUTDOWN (SERVES BUSINESSES), REPLACE PIPING IN VAULT (ITEM 3) BETWEEN SAT 6PM & MON 6AM.
  3. WORK DURING SHUTDOWN: REMOVE ALL EXST PIPING & CONFLICTING CONCRETE. DISINFECT & INSTALL ALL NEW PIPING & VALVES IN VAULT. THEN HAVE JWCD RESTORE 12" WATER MAIN TO SERVICE.
  4. HAVE ENGR VERIFY THERE ARE NO LEAKS, THEN BOND ALL JOINTS & DBL BOND TO ALL VALVES (SEE SHT CP-1 & SPEC 26 42 10); THEN WAX TAPE COAT ALL VALVES IN VAULT.
  5. 30"x30"x30" REINF CONC ENC WAX COATED FLG. #5 BARS AT 22" OC EW EF + 22" DIA #5 HOOPS EA SIDE FLG. BARS SHALL NOT TOUCH PIPING. DRILL #5 DOWELS IN FLOOR & 2 WALLS - 22" OC EW (12 TOTAL).
  6. INSTALL & LEAK TEST 2" SS PIPING TO AV & 60" MH. COMPLETE VALVE BOXES. CLSM FILL (50-150 PSI) VAULT. BACKFILL PIPING. AC REPAVE STREET PER CITY PERMIT.

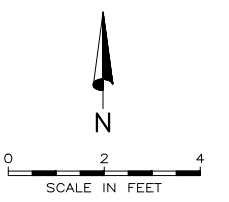

DESIGNED	NPJ	3
DRAFTED	DD	2
CHECKED	TGA	1
DATE	SEPTEMBER 2024	NO.

NO.	DATE	REVISIONS	BY	APVD.

SCALE  
AS SHOWN



2024 VAULT IMPROVEMENT PROJECT  
 CIVIL  
 4330 SOUTH 300 WEST - VAULT

SHEET  
C-8  
127.42.100



FILE NAME: PROJECTS\127 - JVVCD\42.100 - 2023-24 VAULTS IMPROVEMENT\CAD\C-9 VAULT 4500S\_350E.DWG  
 FILE DATE: 9/30/2024 12:23:10 (DD)

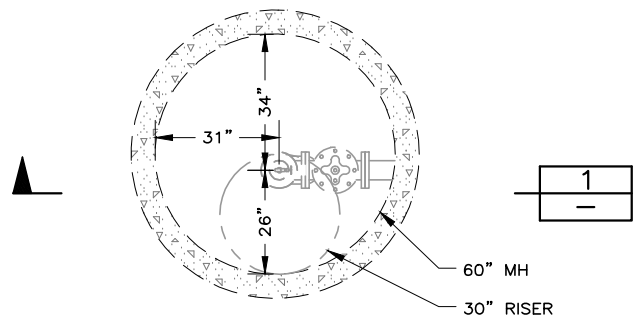

4500S 350E VAULT - EXST PLAN

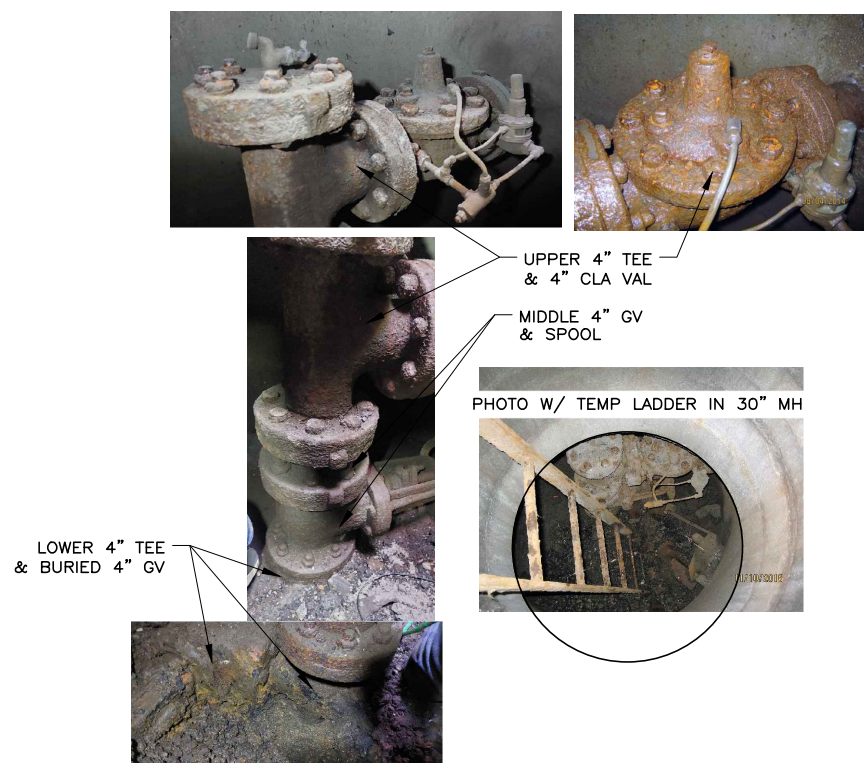

EXST 4" PIPING PHOTOS

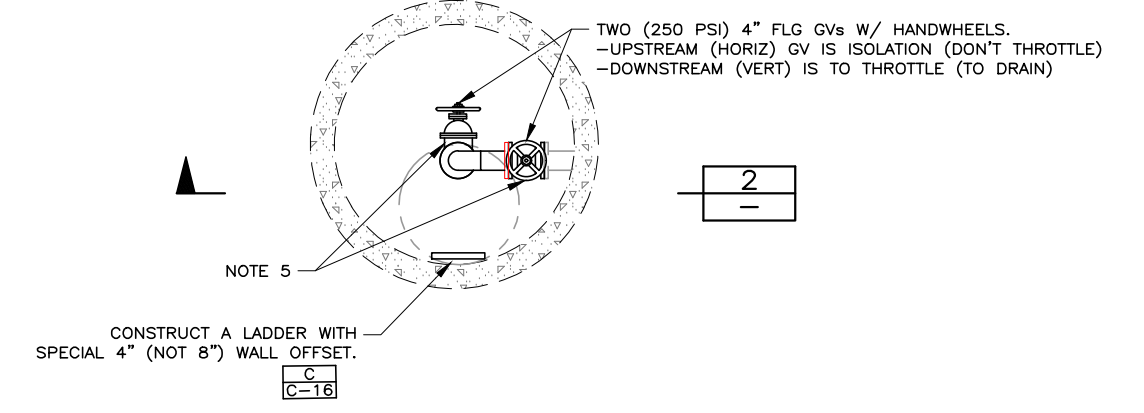

4500S 350E VAULT - REHABILITATED PLAN

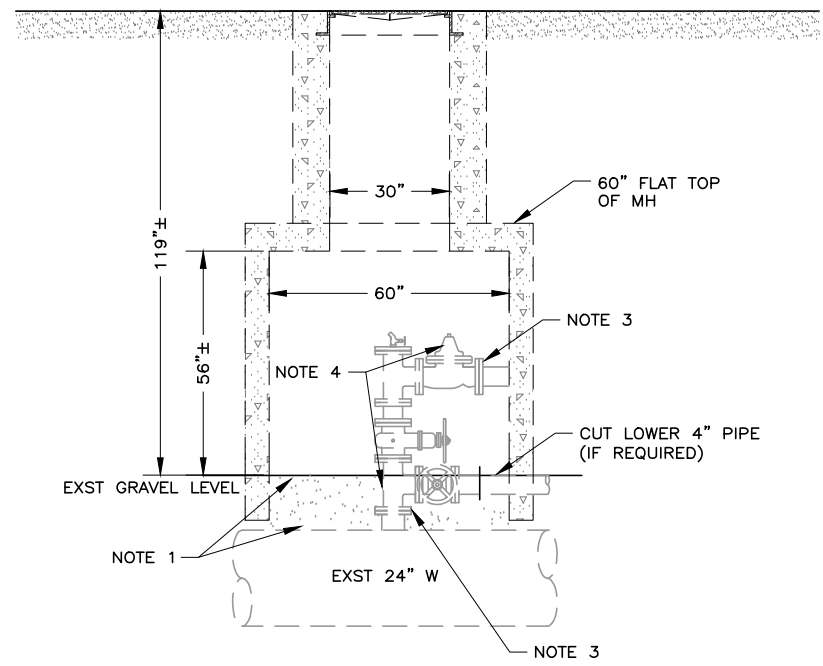

4500S 350W VAULT - EXST SECTION

- NOTES (WORK IN THIS ORDER):**
- HAND-TOOL EXCAVATE GRAVEL TO EXPOSE 24" PIPE FOR 2' AROUND 4" FLG OUTLET.
  - SHUTOFF 24" PIPE.
  - UNBOLT 4" FLGs (MAY NEED TO CUT BOLTS).
  - REMOVE 3 VALVES, 2 TEES & 4" PIPING.
  - INSTALL 2 NEW GVs & 4" WSP (SCH 80, SHOP CML & MC ZINC COAT). FIELD WELD ON (RED) FLGs & CML LINE.
  - TURN ON 24" W. VERIFY NO LEAKS.
  - WASSER COAT (MC ZINC COAT FIELD WELDS & FERROX A&B COAT ALL PIPE & VALVES IN MH). WAX TAPE (TOPCOAT) PIPING TO 10" ABOVE BOTTOM FLG. KEEP WAX OFF HANDWHEELS.

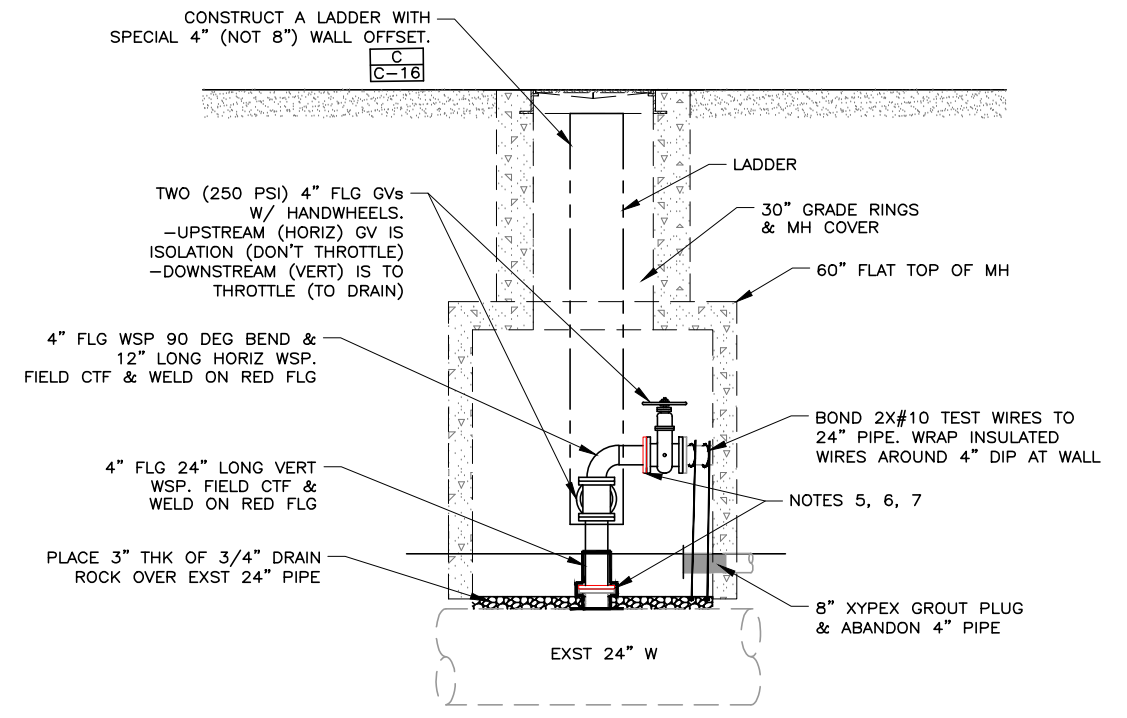

4500S 350W VAULT - REHABILITATED SECTION

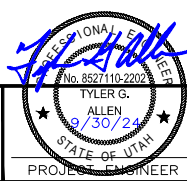

DESIGNED	NPJ	3
DRAFTED	DD	2
CHECKED	TGA	1
DATE	SEPTEMBER 2024	NO.

NO.	DATE	REVISIONS	BY	APVD.

SCALE  
AS SHOWN



2024 VAULT IMPROVEMENT PROJECT  
 CIVIL  
 4500 SOUTH 350 EAST - VAULT

SHEET  
C-9  
127.42.100



FILE NAME: PROJECTS\127\_JVWCD\42.100 - 2023-24 VAULTS IMPROVEMENT\CAD\C-11 VAULT 11400S\_100E-PHOTOS.DWG  
 FILE DATE: 9/30/2024 12:25:07 (DD)



West Side of Vault



West Side of Vault, Control Boxes



SW of Vault & Roof



N Center of Wall - Must Sawcut Roof



NE Corner - Precast Roof



East Wall - Crack Repair Req'd



East Wall Cathodic Negative Header Cables & Test Station Wires



SW Corner Roof (must sawcut center)



4" "F" FLG, Press, Gage



Ladder, Conduits, Grate

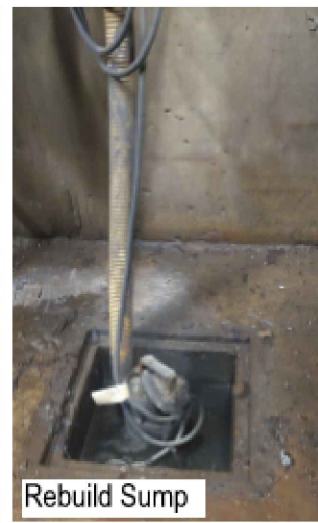

Rebuild Sump



MH, Ladder, Cathodic



4" "F" FLG, AV, Press Gage



8" "F" FLG, Drain

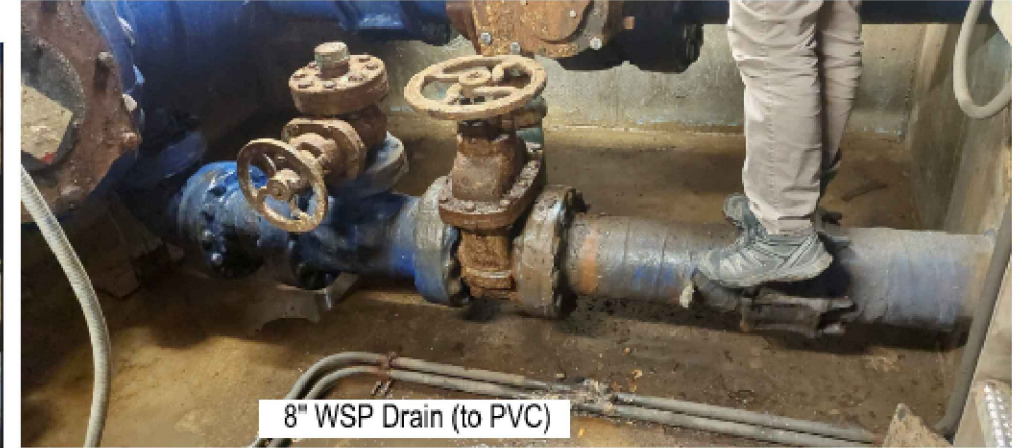

8" WSP Drain (to PVC)



8" Drain to PVC (S Wall)



8" Drain to PVC (S Wall)



8" Drain to PVC (S Wall)

**HANSEN ALLEN & LUCE ENGINEERS**  
 TYLER G. ALLEN  
 9/30/24  
 STATE OF UTAH  
 PROJECT ENGINEER

DESIGNED	NPJ	3
DRAFTED	DD	2
CHECKED	TGA	1
DATE	SEPTEMBER 2024	NO.

NO.	DATE	REVISIONS	BY	APVD.

SCALE AS SHOWN

**JORDAN VALLEY WATER CONSERVANCY DISTRICT**

2024 VAULT IMPROVEMENT PROJECT  
 CIVIL  
 11400 SOUTH 100 EAST — PHOTOS

SHEET C-11  
 127.42.100



FILE NAME: PROJECTS\127\_JVWCD\42.100 - 2023-24 VAULTS IMPROVEMENT\CAD\C-11B VAULT 11400S\_100E.DWG  
 FILE DATE: 9/30/2024 12:26:56 (DD)

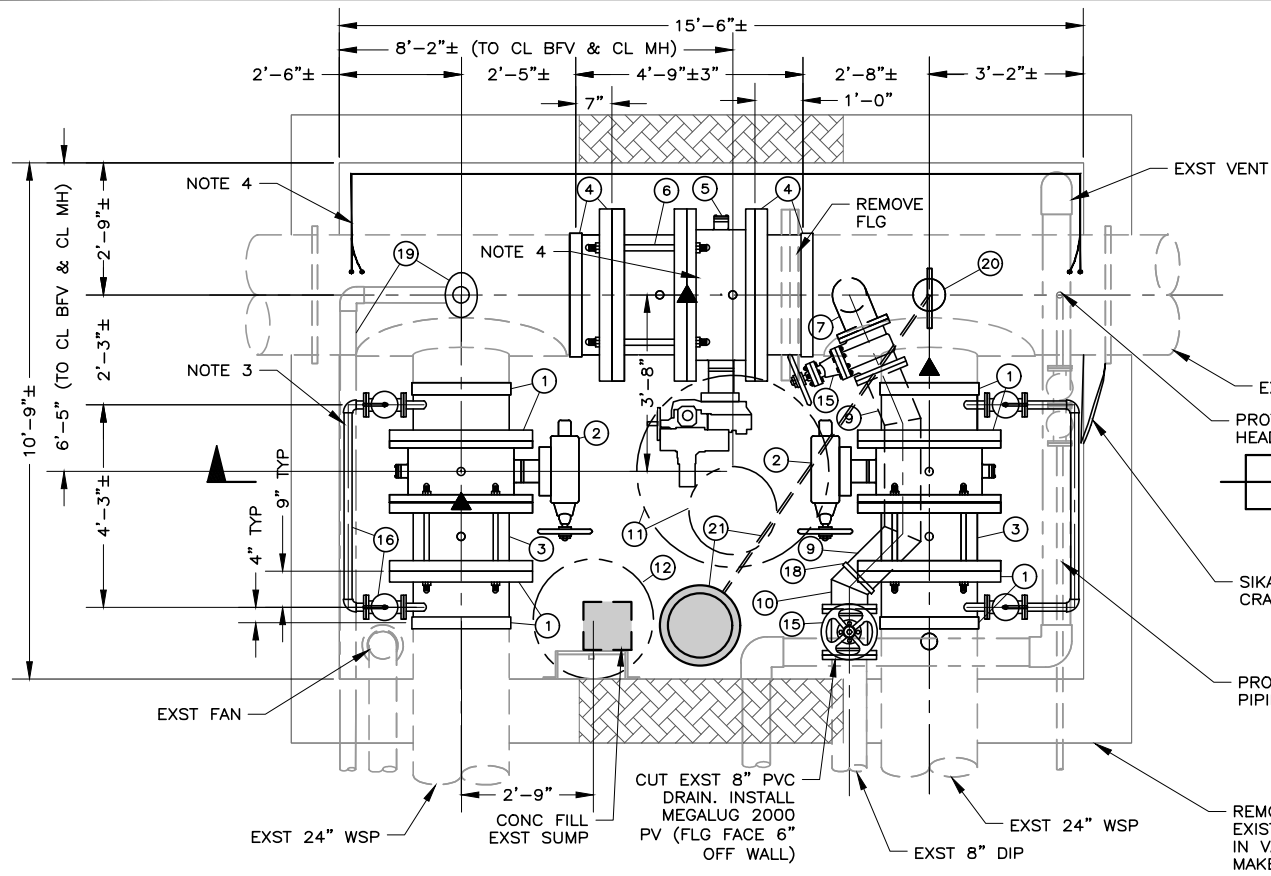

**CONSTRUCTION SCHEDULE:**  
**PRE-SHUTDOWN**  
 1. REMOVE WAX TAPE COAT FROM WSP & SANBLAST EXTERIOR TO SP5 FOR EXISTING PIPING THAT WILL REMAIN.  
**IN-SHUTDOWN**  
 1. EXCAVATE AND REMOVE PRECAST ROOF PANELS.  
 2. CUT OUT OLD VALVES & PIPING.  
 3. INSTALL NEW VALVES & PIPING.  
 4. INSTALL NEW PRECAST ROOF PANELS.  
**POST-SHUTDOWN**  
 1. RELOCATE 8" DRAIN.  
 2. MCU COAT (WASSER MC ZINC, FERROX A & B) ALL NEW & OLD WSP/DIP & VALVES.  
 3. REPAIR WALL CRACK.

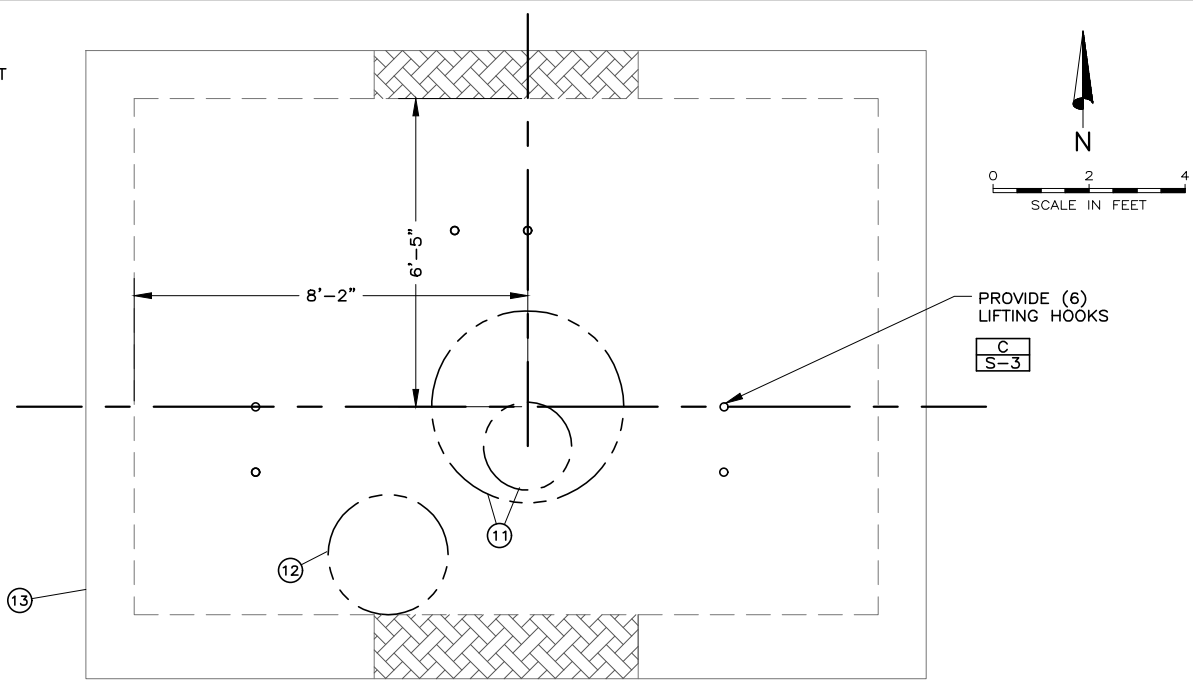

**PLAN - NEW PRECAST ROOF**  
 (SEE SHEET S-3 FOR STRUCTURAL DESIGN)

- MATERIALS SCHEDULE**
- | ITEM | DESCRIPTION  |
|------|--|
| 1    | 24" WSP, CLASS F FLG x BUTT (DET F, SHT C-15), NOTE 3 & 6.   |
| 2    | 24" CLASS 300, FLG DBL ECC BFV, MANUAL ACTUATOR, HANDWHEEL.  |
| 3    | 24" CLASS 300, FLG RESTRAINED DISMANTLING JOINT.   |
| 4    | 30" WSP, CLASS F FLG x BUTT (DET F, SHT C-15), NOTE 3 & 6.   |
| 5    | 30" CLASS 300, FLG DBL ECC BFV, AUTOMATIC ACTUATOR.  |
| 6    | 30" CLASS 300, FLG RESTRAINED DISMANTLING JOINT.   |
| 7    | 8" WSP & 90 DEG SR BEND + 4" LONG WSP SHOP WELDED TO EA END (CTF) & FIELD WELD CLASS F FLGs, NOTE 3.   |
| 8    | NOT USED.  |
| 9    | 8" WSP WITH TWO 30 DEG HZ 1-MITER BENDS 28" APART. So. LEG HAS GE 15" FROM So. MITER. No LEG IS ±14" (PROVIDE 8" CTF) FROM No. LEG MITER TO FIELD WELD SLIP ON CLASS F FLG., NOTE 3.       |
| 10   | 8" WSP 30 DEG HZ 1-MITER BEND. No LEG HAS GE 20" FROM MITER, So. LEG IS 5" LONG TO FACE OF FIELD WELD SLIP ON CLASS F FLG, NOTE 3.   |
| 11   | 48" MH FRAME & COVER (22" INNER MH), HS20 RATED, CLOSED PICK, BOLT DOWN, NEOPRENE SEALED, "WATER" LABEL, SOUTH BAY 1348-1310., OR APPROVED EQUAL.  |
| 12   | 30" MH FRAME & COVER, HS20 RATED, CLOSED PICK, NEOPRENE SEALED, "WATER" LABEL, SOUTH BAY 1252, OR APPROVED EQUAL.  |
| 13   | PRECAST CONC ROOF, SHT S-3. LIFTING EYES OVER EA BFV & DJ.   |
| 14   | NOT USED.  |
| 15   | 8" 350 PSI GATE VALVE W/ CLASS 250 FLGs.   |
| 16   | 2" SCH 80 SS PIPE; TWO CL 300 FULL PORT SS FLG BALL VALVES, FLG DISMANTLING JOINT & TWO (2) WALL SUPPORTS (DET E, SHT C-14).   |
| 17   | PIPE FLOOR SUPPORT (DET D, SHT C-14).  |
| 18   | 8" GE COUPLING.  |
| 19   | AIR VALVE ASSEMBLY (DET F, SHT C-16).  |
| 20   | PRESSURE GAGE ASSEMBLY (DET E, SHT C-16).  |
| 21   | REPLACE SUMP PUMP PER SPECS (& DET G, SHT C-16). DRAIN FLOOR LOW SPOT: SAWCUT (1/2" WIDE x 1/4" DEEP) TRENCH IN CONC FLOOR FROM UNDER ITEM 20 TO ITEM 21. GRIND SIDES SO TOP WIDTH IS ±1". |
- NOTES:**
- 11400 S PIPELINE SHUTDOWN TIME ALLOWED: 72 HOURS. COORDINATE TIMING W/ JWCD, UDOT, SANDY & DRAPER. SEE SHT C-11A, NOTE A. INSTALL ITEMS 7 & 8 IN-SHUTDOWN & ITEMS 9 & 10 POST-SHUTDOWN.
  - AFTER INSTALLING VALVES & RESTORING 11400 S PIPE SERVICE, HIGH PRESSURE (200 PSI) WASH VAULT FLOOR AND WALLS TO OWNER/ENGINEER SATISFACTION.
  - SHOP ASSEMBLE PIPING & VALVES (W/ 2" SS LOOP W/ 2" UNION. FIELD FIT (CTF) ASSEMBLED PIPING & TACK WELD IN PLACE. DISASSEMBLE PIPING, WELD JOINTS & FINISH CML THEN REASSEMBLE PIPING. COMPLY WITH WSP NOTES 1 THROUGH 7 ON SHEET C-15.
  - PROVIDE 2 #2 CABLES. BOND EACH TO 30" WSP 6" INSIDE EA END OF VAULT. MOUNT CABLES TO WALL IN A 2" SCH 40 PVC CONDUIT ±2' BELOW ROOF.
  - VAULT ROOF STRUCTURAL ON SHT S-3.
  - EXST 24" WSP OD=25.9"± (81.5"± PERIMETER OF WAX TAPE COATED SPIRAL SEAM WSP MEASURED 4 PLACES). EXST 30" WSP OD=32.7"± (102.8"± PERIMETER OF WAX TAPE COATED SPIRAL SEAM WSP MEASURED 2 PLACES).
  - SEE E SHEETS FOR ELECTRICAL AND CONTROLS.
- ▲ ADJUSTABLE PIPE SUPPORT, SEE DETAIL D ON C-14.

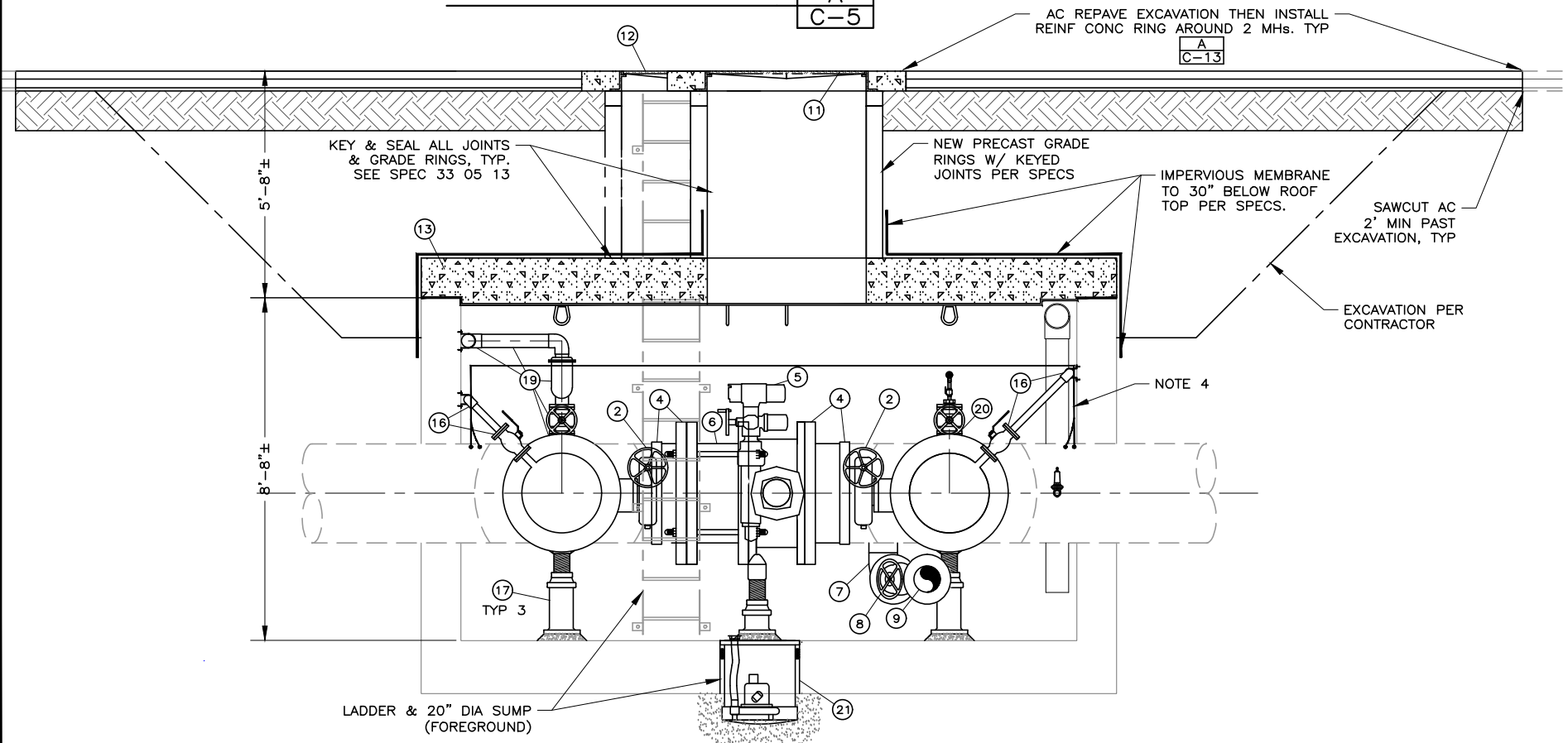

**11400S 100E VAULT - SECTION**

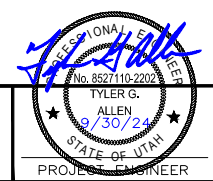

DESIGNED NPJ	3				
DRAFTED DD	2				
CHECKED TGA	1				
DATE SEPTEMBER 2024	NO.	DATE	REVISIONS	BY	APVD.

SCALE AS SHOWN





FILE NAME: PROJECTS\127\_JVWCD\42.100 - 2023-24 VAULTS IMPROVEMENT\CAD\C-12 VAULT 11400S\_700E\_R1.DWG  
 FILE DATE: 9/30/2024 12:28:11 (DD)

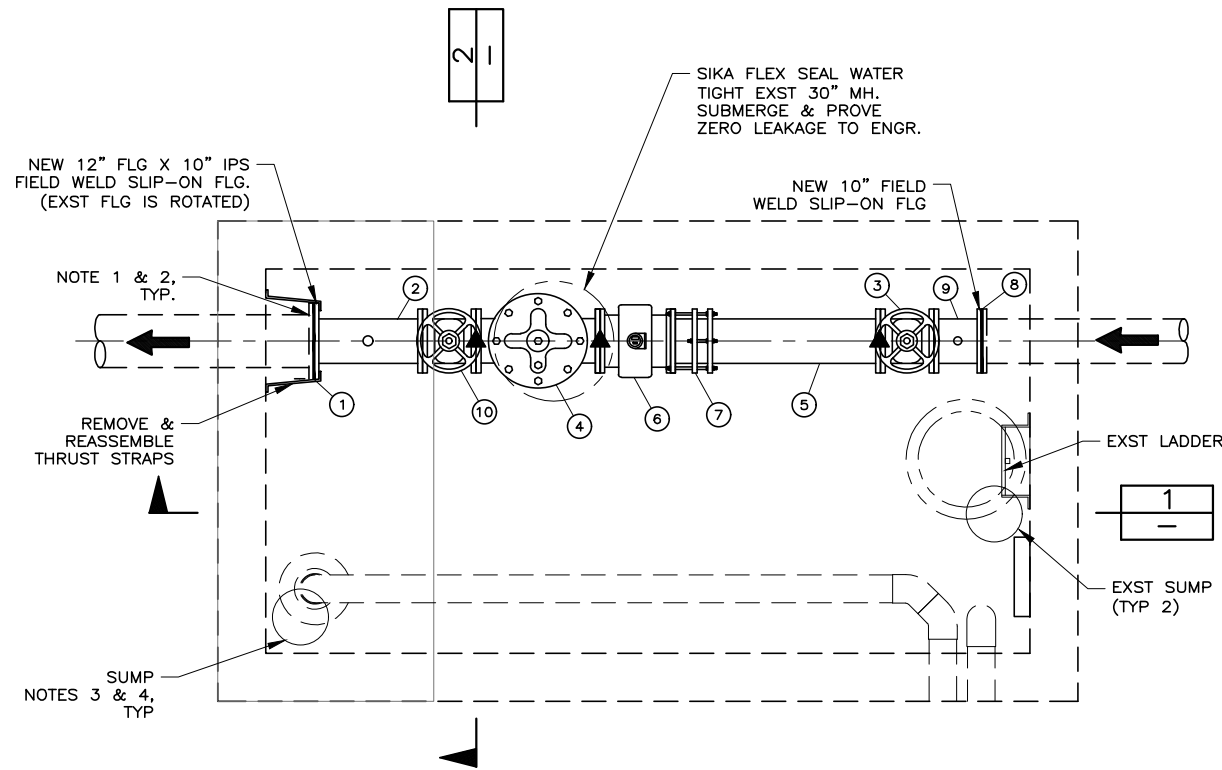

11400S 700E VAULT - PLAN

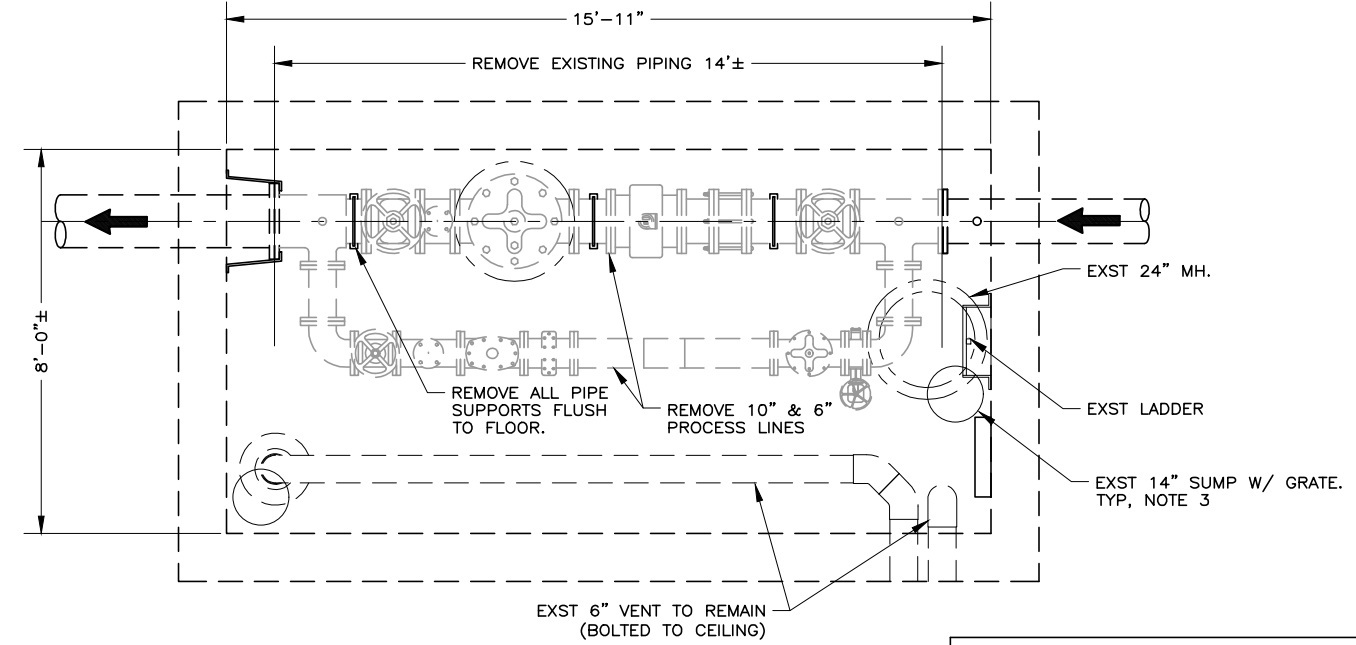

11400S 700E EXST VAULT (DEMOLITION)

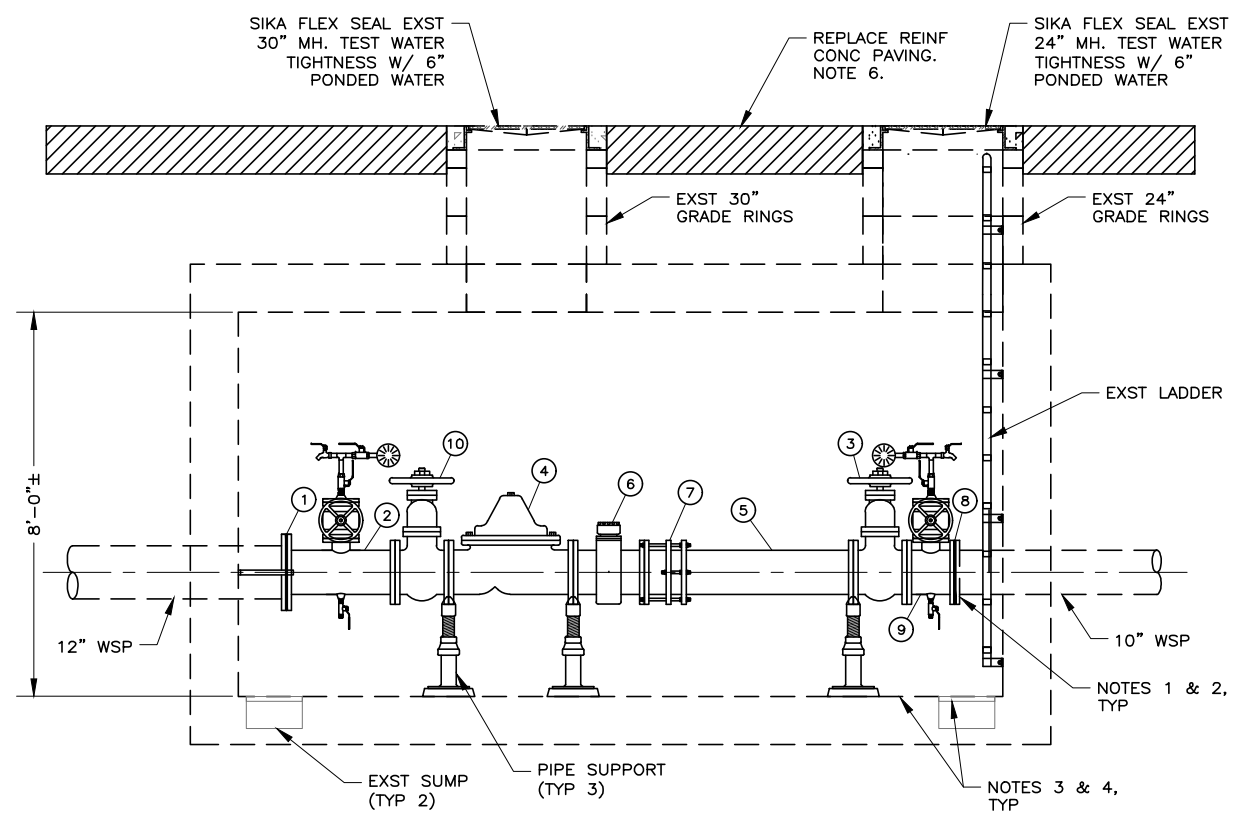

11400S 700E VAULT - SECTION

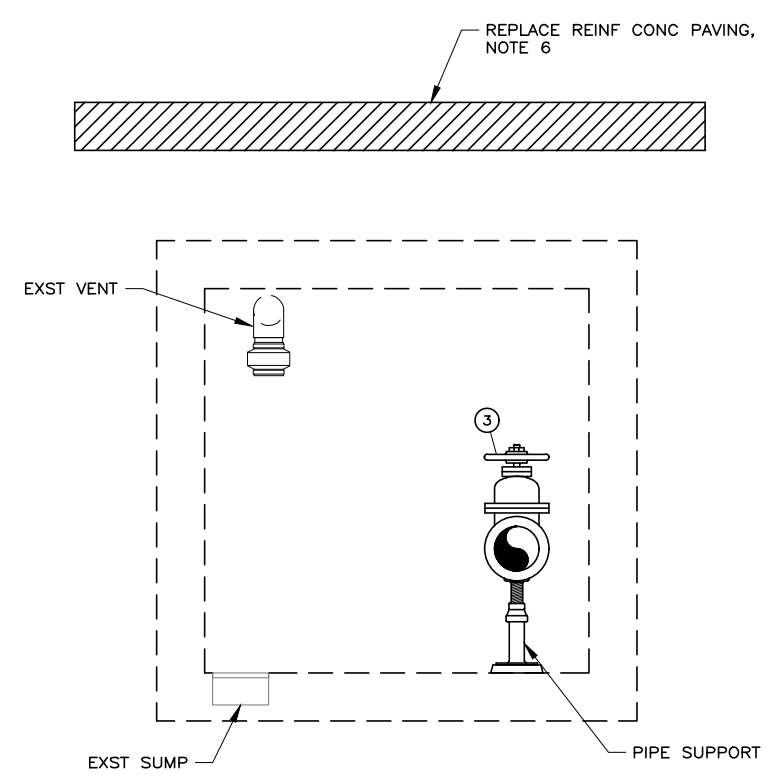

11400S 700E VAULT - SECTION

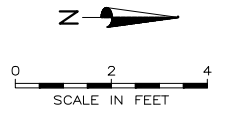

VALVE & FITTING SCHEDULE			
NO.	DESCRIPTION	SIZE	JOINT
1.	INSULATING FLANGE KIT (NOTE 1)	12"	FLG
2.	10" WSP, 20" LONG, NOTE 5. W/ PRESSURE GAUGE ASSEMBLY DET E, SHT C-16; + 0-400 PSI PRESS GAGE + 2" OUTLET (DOWN) DET F, SHT C-14 W/ THD PLUG	10"	FLG
3.	GATE VALVE, 350 PSI, CL 250 FLG	10"	FLG
4.	SINGER 106-PR 300 PSI PRV VALVE GLOBE VALVE	10"	FLG
5.	10" WSP, CONTRACTOR FIT PIPE LENGTH TO VALVES, NOTE 5. W/ PRESSURE GAUGE ASSEMBLY DET E, SHT C-16; + 0-400 PSI PRESS GAGE + 2" OUTLET (DOWN) DET F, SHT C-14 W/ THD PLUG	10"	FLG
6.	MAG METER, ROSEMOUNT PER SPECS	10"	FLG
7.	RESTRAINED DISMANTLING JOINT	10"	FLG
8.	INSULATING FLANGE KIT (NOTE 1)	10"	FLG
9.	10" WSP, 12" LONG, NOTE 5	10"	FLG
10.	250 PSI GATE VALVE DOWNSTREAM	10"	FLG
11.	OUTLET (SIDE) DET F, SHT C-14 W/ 400 PSI HOSE BIBB	3/4"	THD

NOTES:

- SANDBLAST EXST PIPE & FLG & FIELD COAT PER SPECS.
- ASSEMBLE PIPING & THRUST STRAPS. TACK WELD SLIP ON FLGS. DISASSEMBLE PIPING, WELD SLIP ON FLGS, MORTAR LINE & WASSER COAT. ENGR MUST INSPECT FIELD LINING & COATING. REASSEMBLE PIPING & THRUST STRAPS.
- MAY REUSE EXST SUMP COVERS IF SANDBLASTED & (WASSER) FIELD COATED PER SPECS.
- HIGH PRESSURE WATER JET (>200 PSI) CLEAN FLOOR AND BOTTOM 2' OF WALLS TO OWNER SATISFACTION.
- USE STD WT WSP. C205 MORTAR LINE. WASSER COAT (MOISTURE CURED URETHANE).
- REMOVE & REPLACE 11" THK CONC PAVING (REPLACE FULL PANELS, REINFORCE JTS) PER UDOT PERMIT, STANDARD SPECS & PLAN REQUIREMENTS ON SHTS PV-0 TO PV-10; UDOT RAPID CURE CONC, RAPID CURE CLSM (FILL), ETC. EXST PANEL LAYOUT PER SHT C-8.

▲ ADJUSTABLE PIPE SUPPORT, SEE DETAIL D ON C-14.



DESIGNED	NPJ	3
DRAFTED	DD	2
CHECKED	TGA	1
DATE	SEPTEMBER 2024	NO.

NO.	DATE	REVISIONS	BY	APVD.

SCALE  
AS SHOWN



2024 VAULT IMPROVEMENT PROJECT  
 CIVIL  
 11400 SOUTH 700 EAST - VAULT

SHEET  
C-12  
127.42.100



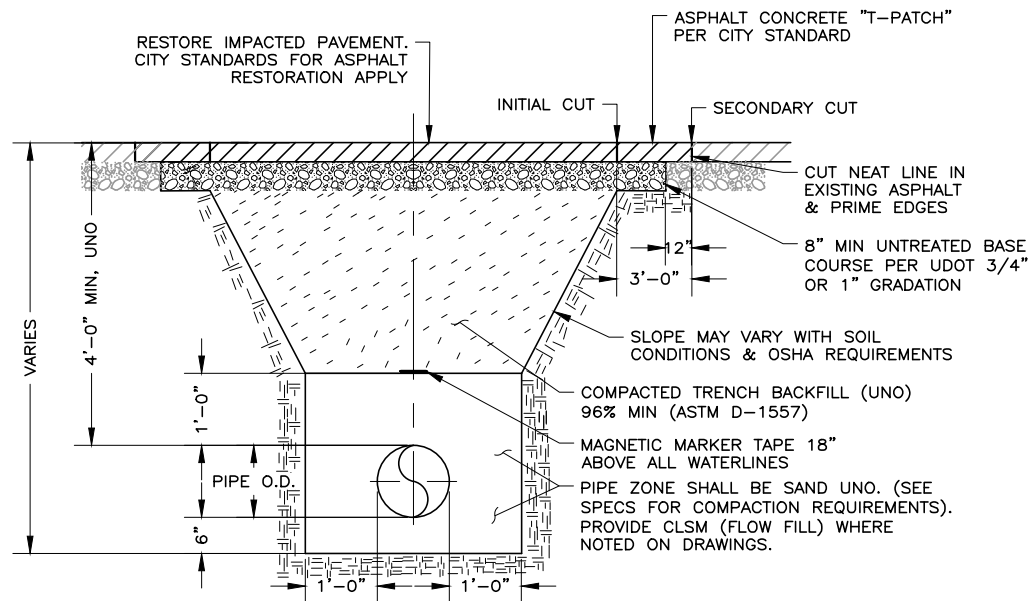

TYPICAL TRENCH DETAIL 

A
-

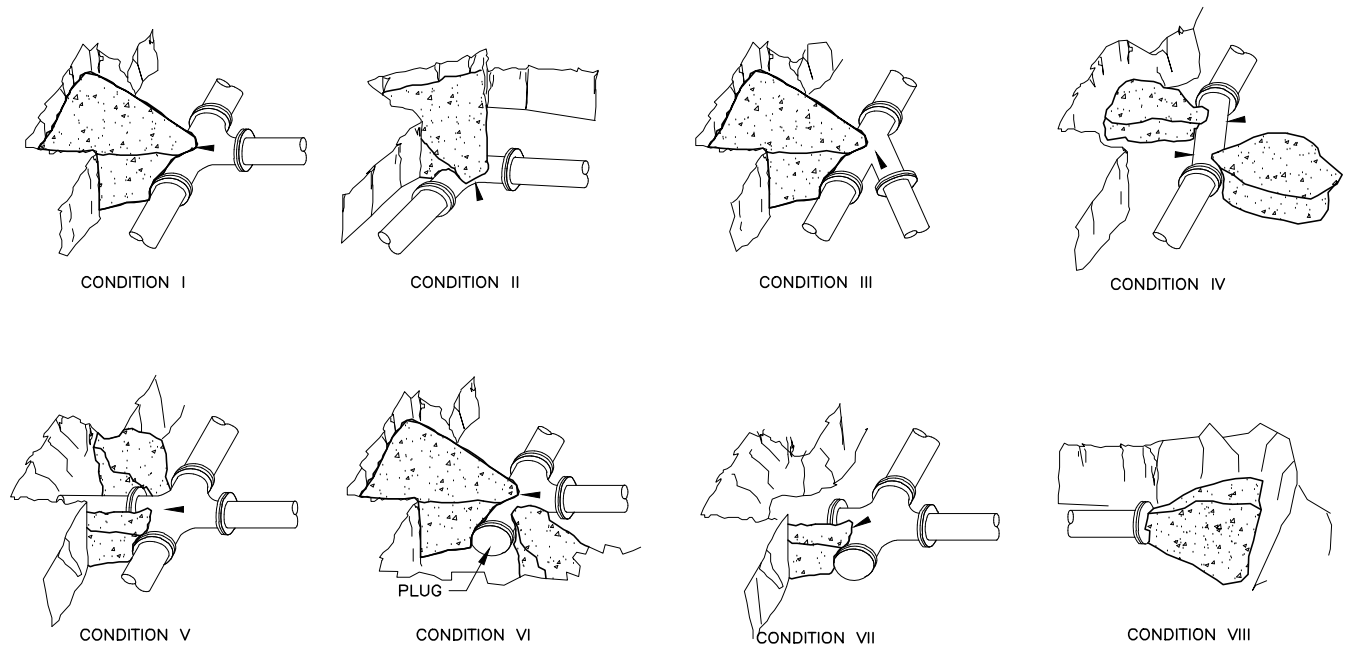

THRUST BLOCK BEARING AREA IN SQ. FEET

NOMINAL PIPE SIZE (IN)	DIP ID (IN)	CONDITION							
		I	II	III	IV	V	VI	VII	VIII
4	4.3	2.2	3.1	1.5	1.7	1.1	2.2	3.1	2.2
6	6.4	4.8	6.8	3.4	3.7	2.4	4.8	6.8	4.8
8	8.6	8.6	12.2	6.1	6.6	4.3	8.6	12.2	8.6
10	10.6	13.2	18.6	9.3	10.1	6.6	13.2	18.6	13.2
12	12.6	18.8	26.6	13.3	14.4	9.4	18.8	26.6	18.8
14	14.7	25.6	36.2	18.1	19.6	12.8	25.6	36.2	25.6
16	16.8	33.3	47.0	23.5	25.4	16.7	33.3	47.0	33.3
18	18.9	42.0	59.4	29.7	32.1	21.0	42.0	59.4	42.0
20	20.9	51.7	73.1	36.5	39.5	25.9	51.7	73.1	51.7
24	25.1	74.0	104.6	52.3	56.6	37.0	74.0	104.6	74.0
30	31.2	114.4	161.8	80.9	87.5	57.2	114.4	161.8	114.4
36	37.5	164.4	232.5	116.3	125.9	82.2	164.4	232.5	164.4

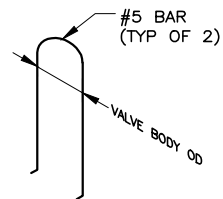
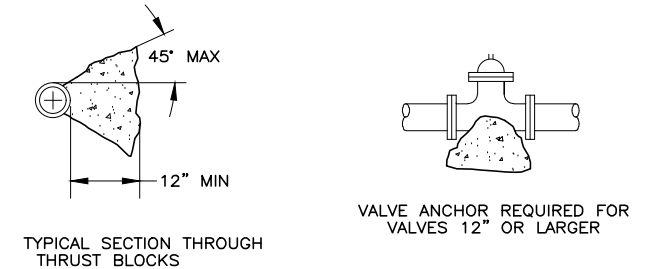

DETAIL: EPOXY COATED #5 BAR (GV ANCHOR) 

B
-

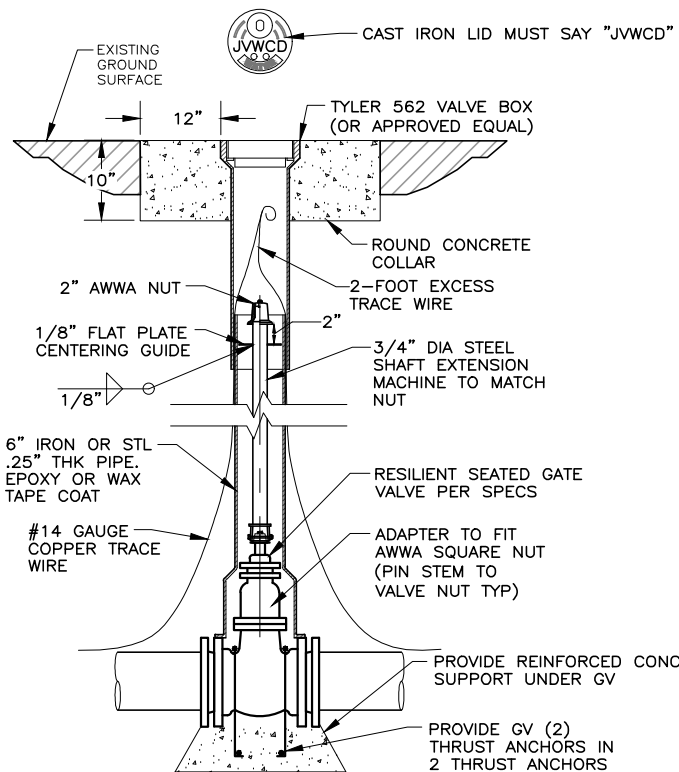

- NOTES:
- VALVE OPERATING NUT SHALL BE WITHIN 3' TO FINISHED SURFACE. EXTENSION STEMS WITH ROCK SHIELDS SHALL BE PROVIDED WHERE DEPTHS EXCEED 4'.
  - PROVIDE AN EPOXY PROTECTIVE COATING TO EXTERIOR SURFACE OF VALVE STEM RISER.
  - VALVES AND CONNECTIONS SHALL BE POLY WRAPPED WITH GREASED HARDWARE USING 3" WIDE PVC TAPE.

BURIED GATE VALVE & VALVE BOX 

C	C
C-7	C-8

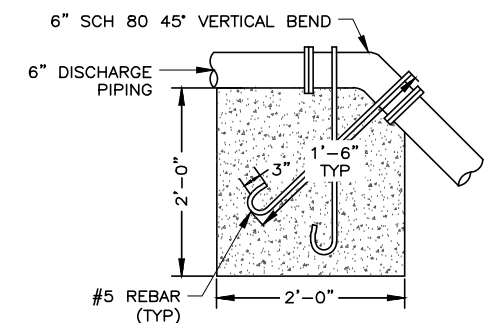

6" DISCHARGE PIPE GRAVITY BLOCK DETAIL

DETAIL NOTES:

- ALL THRUST BLOCK BEARING FACES SHALL BE POURED AGAINST UNDISTURBED SOIL OR APPROVED COMPACTED BACKFILL.
- CONCRETE SHALL BE CLASS 6.0-B-3000.
- ALL THRUST BLOCK SIDES SHALL BE FORMED.
- CALCULATED ON 200 LB. TEST PRESSURE AND ALLOWABLE BEARING PRESSURE OF 2000 LBS. PER SQUARE FOOT.
- IN POORER SOILS SPECIAL DESIGN IS REQUIRED.
- THRUST RESTRAINT TO INCLUDE THRUST BLOCK AND JOINT RESTRAINT AT ALL PIPEBENDS.

TYPICAL THRUST BLOCK / RESTRAINT DETAILS 

D
-

FILE NAME: PROJECTS\127 - JVWCD\42.100 - 2023-24 VAULTS IMPROVEMENT\CAD\C-13 TYPICAL DETAILS I.DWG  
FILE DATE: 9/30/2024 12:40:46 (DD)

7/04



DESIGNED	NPJ	3
DRAFTED	DD	2
CHECKED	TGA	1
DATE	SEPTEMBER 2024	NO.

NO.	DATE	REVISIONS	BY	APVD.

SCALE NOT TO SCALE



2024 VAULT IMPROVEMENT PROJECT  
CIVIL  
TYPICAL DETAILS I

SHEET C-13  
127.42.100



FILE NAME: PROJECTS\127 - JVVCD\42.100 - 2023-24 VAULTS IMPROVEMENT\CAD\C-14 TYPICAL DETAILS\_IL.RT.DWG  
 FILE DATE: 9/30/2024 12:43:04 (DD)

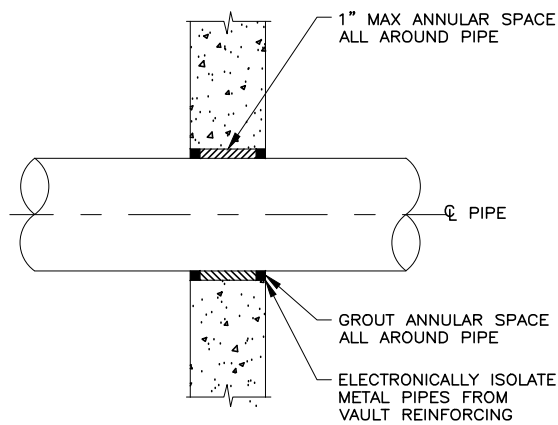

WALL PIPE GROUDED PENETRATION 

A
-

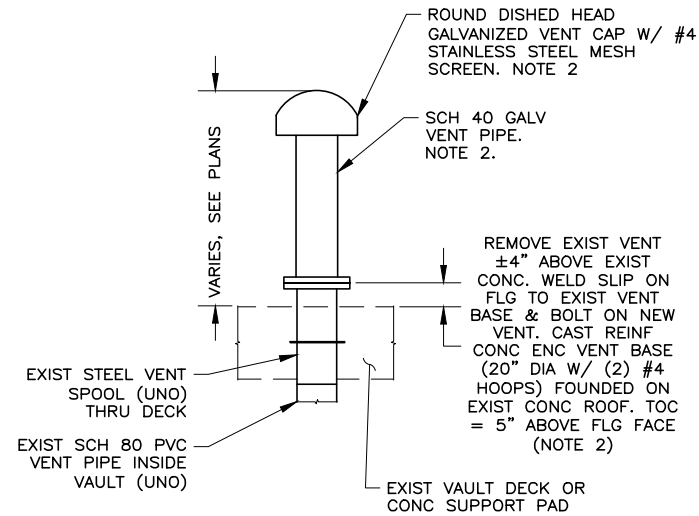

- NOTES:
- VENT PIPE DIA IS CALLED OUT ON VAULT/MH PLANS.
  - SYSTEM 4 PAINT OVER GALV VENT (BLACK OR WHITE, PER PLANS)

REPLACE EXIST PERF VENT W/ MUSHROOM VENT 

B	B
-	C-8

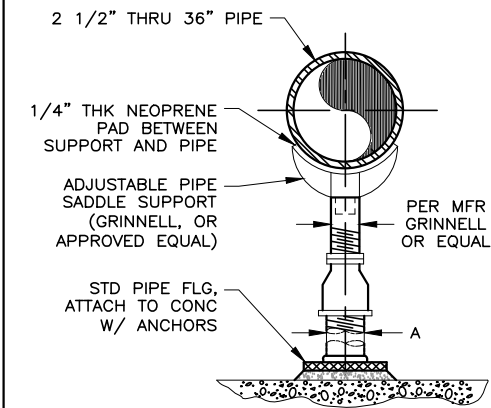

DIMENSION TABLE	
PIPE SIZE	A
2-1/2"	2-1/2"
3"	2-1/2"
4"	3"
6"	3"
8"	3"
10"	3"
12"	3"
14"	4"
16"	4"
18"	6"
20"	6"
24"	6"
30"	6"
36"	6"

PIPE SUPPORT - FLOOR MOUNTED 

D	D
C-11B	C-12

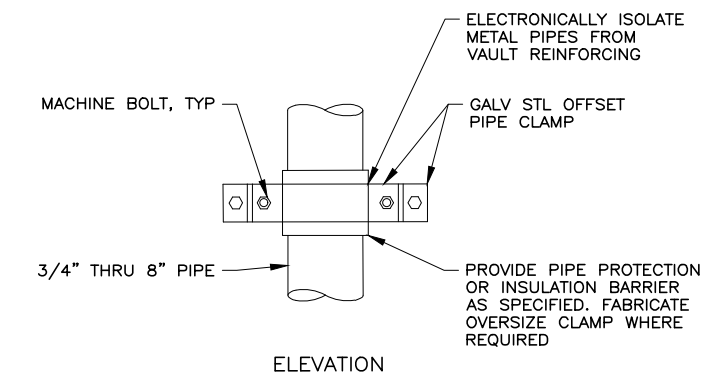

PIPE SUPPORT - WALL MOUNTED 

E
C-11B

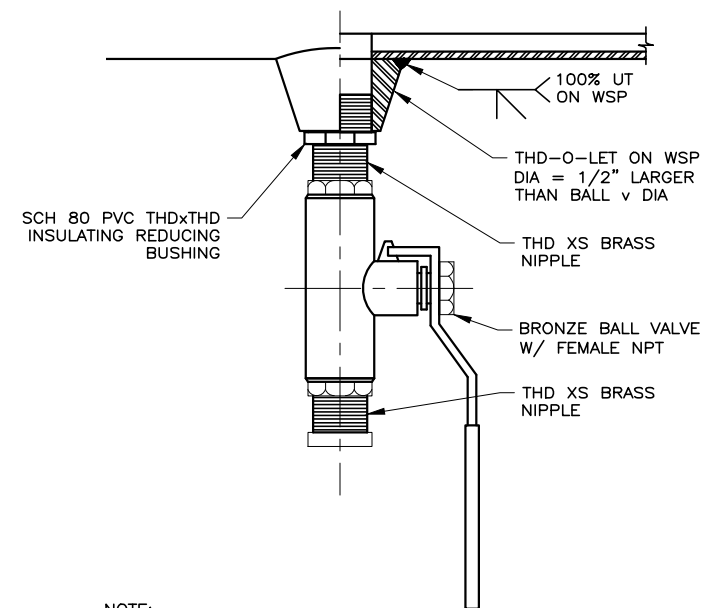

- NOTE:
- IF WSP CONNECTS TO COPPER OR BRASS PIPE, USE XS THD BRASS PIPE & THD BRONZE BALL VALVE PRESSURE RATED 200 PSI MIN HIGHER THAN PIPELINE.

WSP OUTLET TO BALL VALVE 

F
-

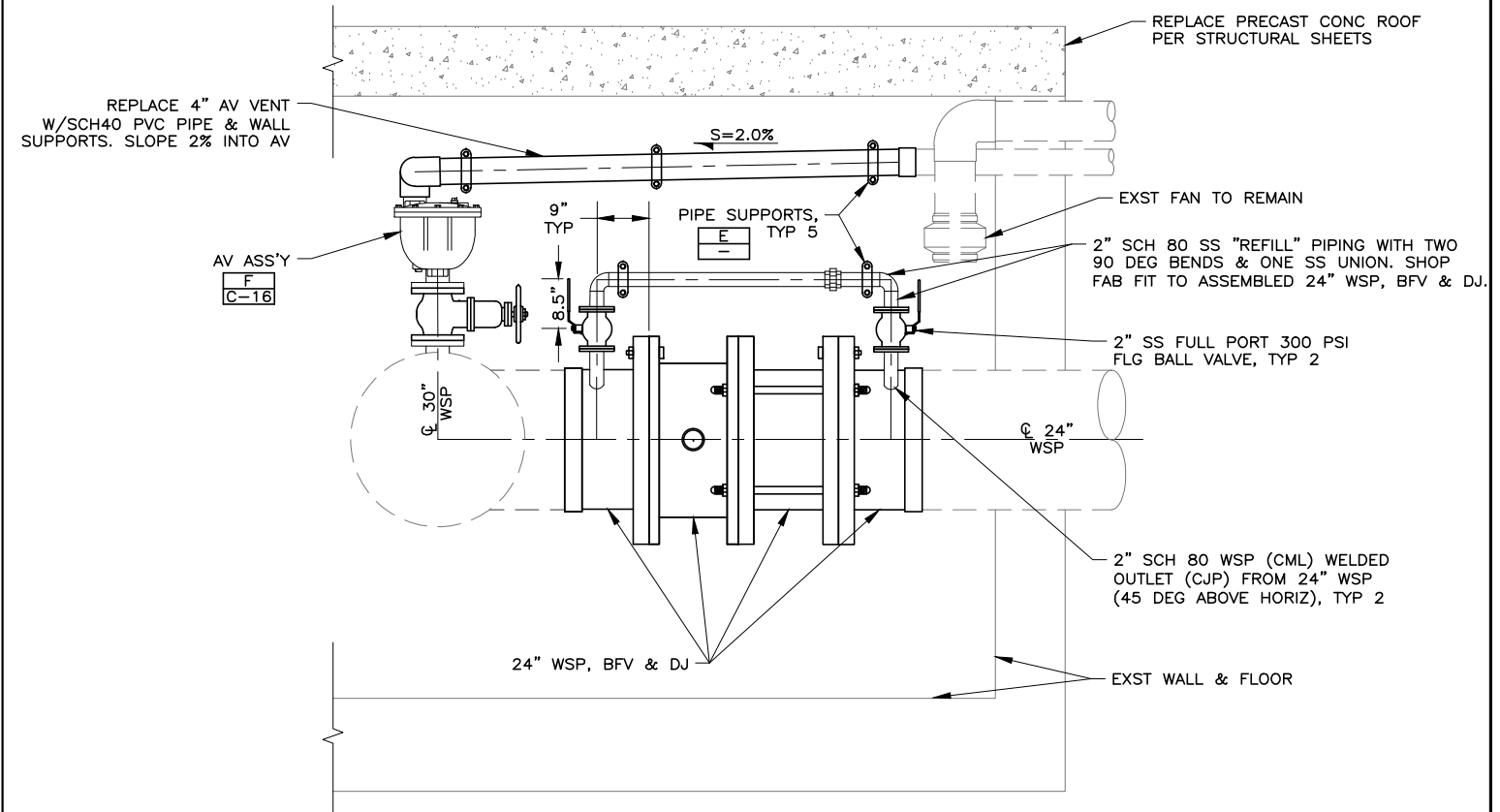

2" REFILL LINE BYPASS PIPE 

G
C-11B



FILE NAME: PROJECTS\127 - JVVCD\42.100 - 2023-24 VAULTS IMPROVEMENT\CAD\C-15 TYPICAL DETAILS III.DWG  
 FILE DATE: 9/30/2024 12:43:45 (DD)

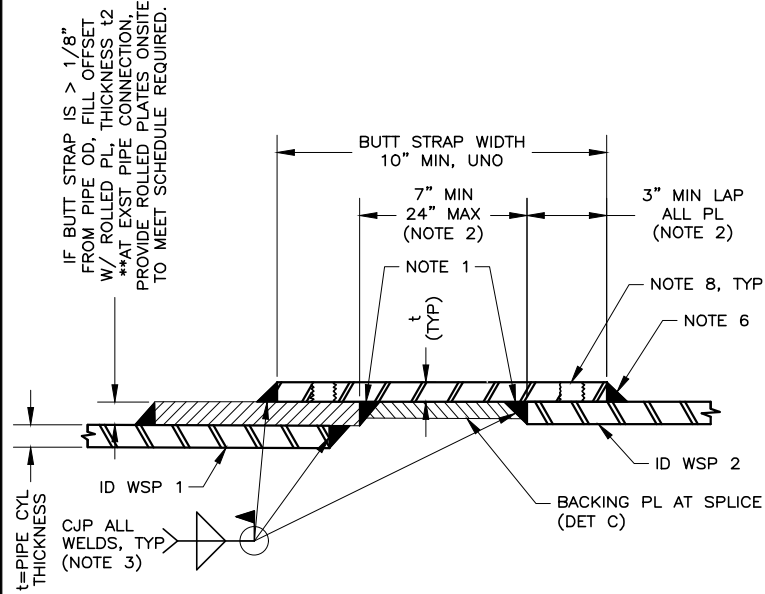

**BUTT STRAP CONNECTION TO WSP** A  
 NTS

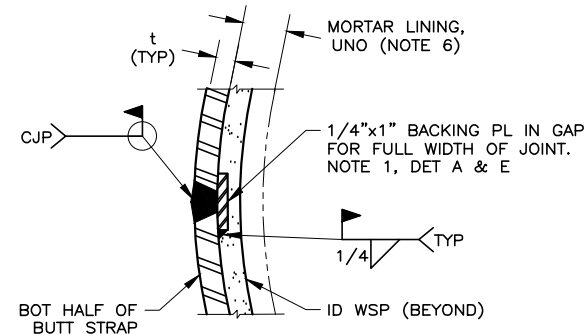

**BUTT STRAP SPLICE** B  
 NTS

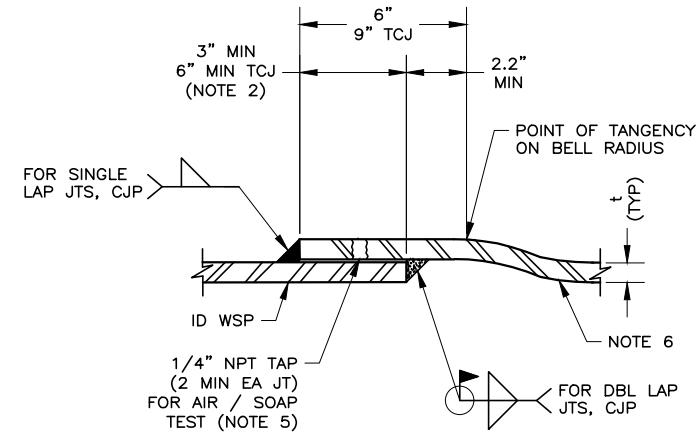

**LAP WELDED JOINT (SINGLE & DBL)** C  
 NTS

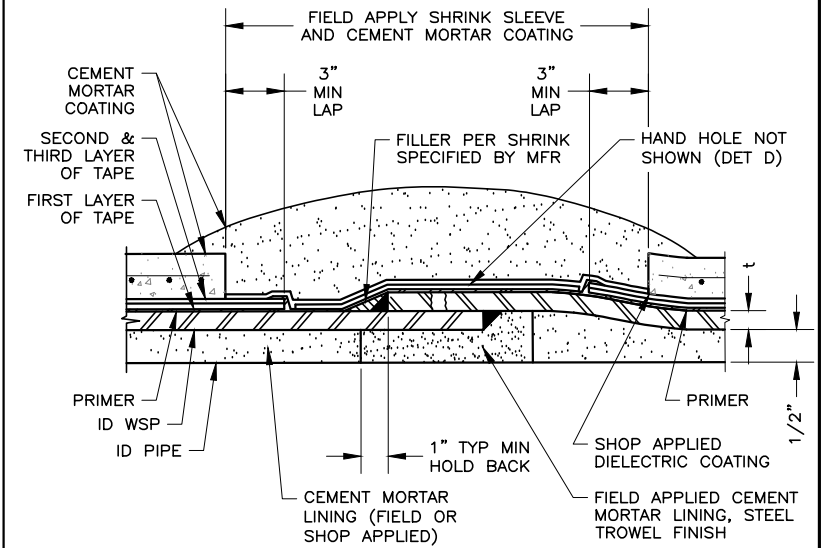

**BURIED JOINTS LINING & COATING:  
 SHRINK SLEEVE COAT / MORTAR LINE & COAT** D  
 NTS

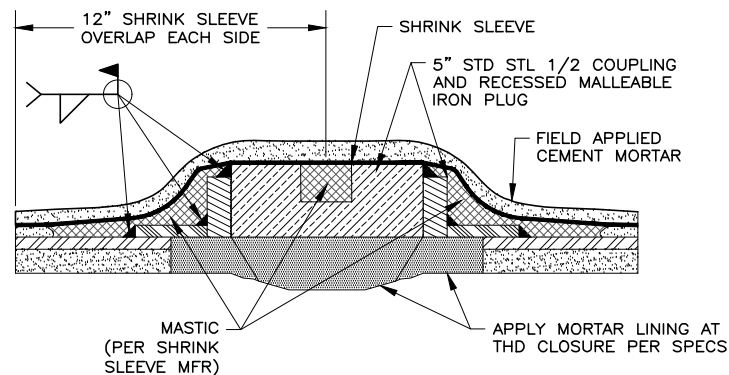

**DETAIL NOTE:**  
 HAND HOLES SHALL BE INSTALLED AT WELDED CLOSURE JOINTS (I.E BUTT STRAPS) FOR ACCESS TO APPLY LINING (NOTE 2).

**BURIED BUTT STRAP - HAND HOLES** E  
 NTS

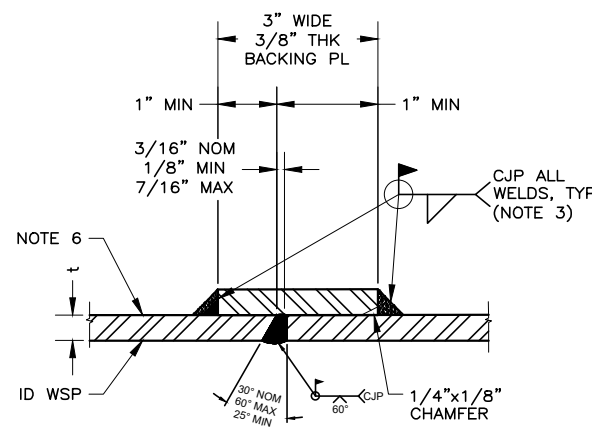

**DETAIL NOTE:**  
 FOR EACH BUTT WELDED FIELD JOINT WITH BACKING PLATE: INSPECT WITH AN ENGINEER-APPROVED, QUALIFIED CWI FOR RADIOGRAPHIC (RT), OR ULTRASONIC (UT) INSPECTION AND SUBMIT CWI INSPECTION REPORT ON EACH JOINT.  
 ALTERNATELY, USE A BUTT STRAP JOINT (PER DETAIL A) AND SUBMIT CWI AIR SOAP TEST FOR EACH PER NOTE 8.

**BUTT WELDED FIELD JOINT W/ BACKING PL** F  
 NTS C-11

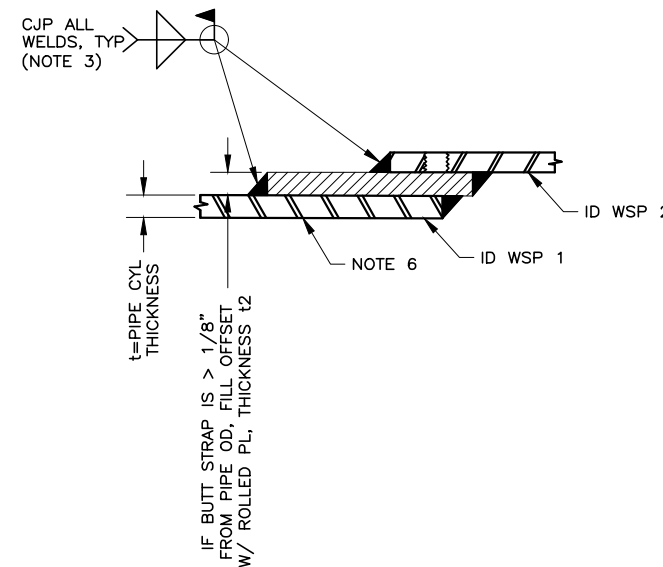

**CONNECTING (2) WSP'S OF DIFFERENT DIA W/ FILLER PL** G  
 NTS

**WSP NOTES:**

- BUTT STRAP SPLICE PLATE: BEVEL ENDS BEFORE WELDING OR BACK GOUGE CONTACT TO ADJACENT CYL BEFORE COMPLETING INSIDE FILLET WELD. OMIT INSIDE WELDS ON 12" WSP.
- SEE SPECS FOR LINING AND COATING BUTT STRAPS AND CLOSURES. PROVIDE SHOP-CML, FLG'D OUTLET (NOT SHOWN). WELD BUTT STRAP, THEN CML. INSTALL 6" BLD FLG. WAX TAPE COAT BUTT STRAP + OUTLET.
- PROVIDE COMPLETE JOINT PENETRATION (CJP) WELDS. WELD THICKNESS SHALL MATCH PLATE THICKNESS WELDED TO. PROVIDE 3/8" WELDS UNO.
- FOR EACH FIELD WELD: SUBMIT CERTIFIED WELDING INSPECTOR (CWI) TESTS (VISUAL VT, DYE PEN DP, MAG PARTICLE MT, ULTRASONIC UT, X-RAY RT, AIR SOAP). REPORTS SHALL LIST CWI, TEST, DATE, WPS, PQR, & THAT EACH WELD COMPLIES WITH AWS D1.1. SEE SPEC 33 92 10.
- NEW WSP IN VAULTS: SHOP MORTAR LINE & ZINC PRIME COAT. FIELD COAT (WASSER FERROX A&B). EXST WSP IN VAULTS: SANDBLAST EXTERIOR & SYSTEM 4 COAT (WASSER MC ZINC, FERROX A&B).
- WSP LININGS AND COATINGS - SEE NOTES 6A TO 6D:
  - LININGS & COATINGS ARE NOT SHOWN IN DETAILS FOR CLARITY. LINE & COAT BURIED JOINTS PER SPEC 09 98 10.
  - COAT BURIED JOINTS W/ HEAT SHRINK & HOLIDAY TEST, THEN MORTAR TOP COAT. MAY OMIT MORTAR COATING AT JOINTS IF PIPE ZONE IS CLSM.
  - MORTAR LINE JOINTS PER SPEC 09 98 10 UNO. WHERE CALLED OUT, EPOXY LINE JOINTS PER SPEC 09 90 00.
  - COAT PIPING IN VAULTS WITH MOISTURE CURED URETHANE SYSTEM (WASSER MC ZINC, FERROX A, FERROX B) PER SPECS.
- FIELD CTF WSP: ASSEMBLE PIPING. CTF WSP & TACK WELD IN PLACE. THEN DISASSEMBLE PIPING & CJP BUTT WELD JOINT (OR SLIP-ON FLG FILLET WELD INSIDE & OUT). THEN CEMENT MORTAR LINE (CML) & WASSER COAT (NOTE 6D). LET CML CURE, THEN REASSEMBLE PIPING.
- OMIT AIR SOAP TEST ON 12" WSP.



DESIGNED NPJ	3
DRAFTED DD	2
CHECKED TGA	1
DATE SEPTEMBER 2024	NO. DATE

REVISIONS

BY APVD.

SCALE NOT TO SCALE



2024 VAULT IMPROVEMENT PROJECT  
 CIVIL  
 TYPICAL DETAILS IV

SHEET  
 C-15  
 127.42.100



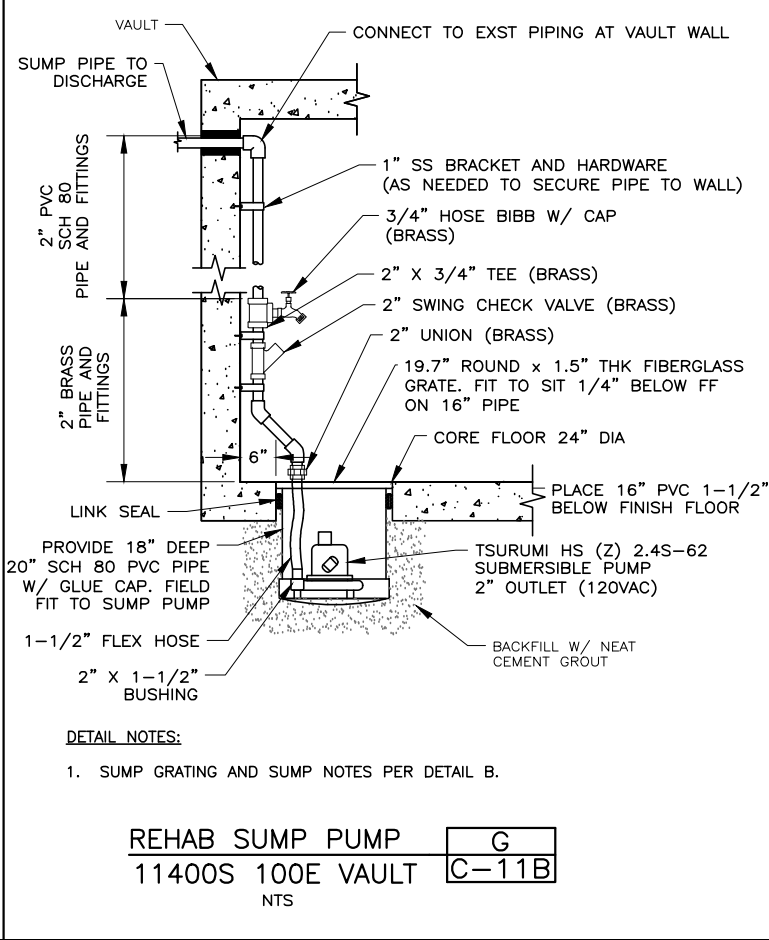
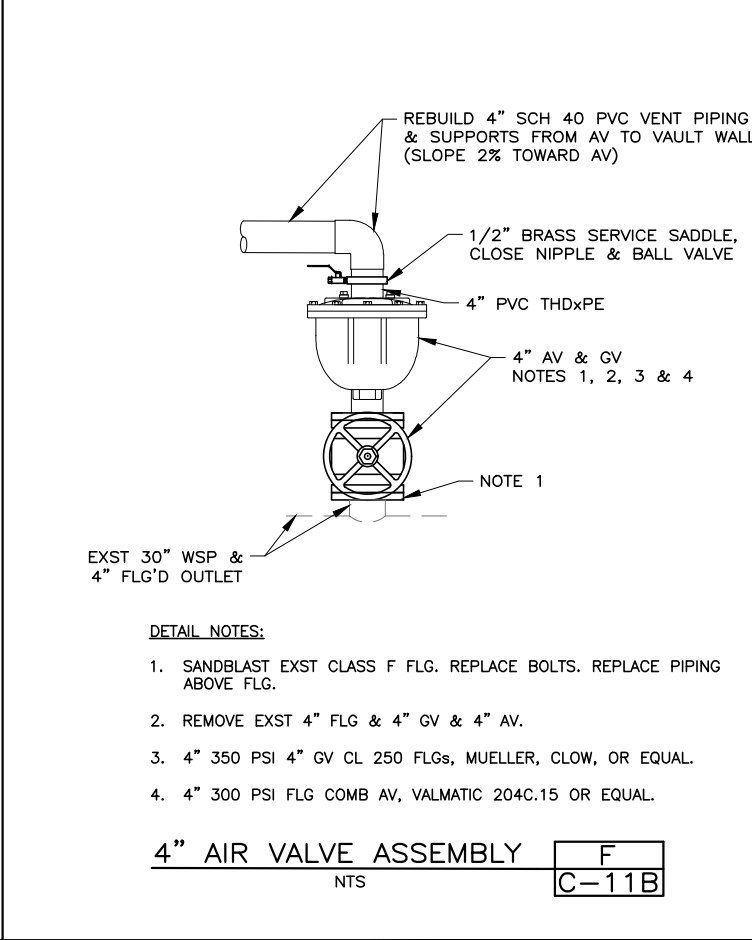
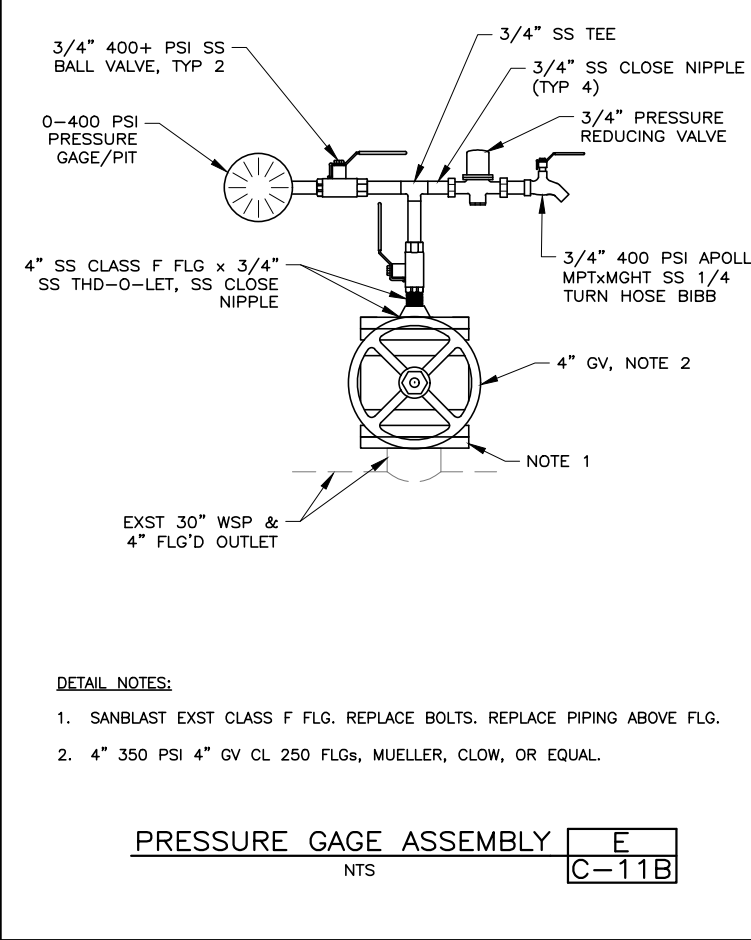
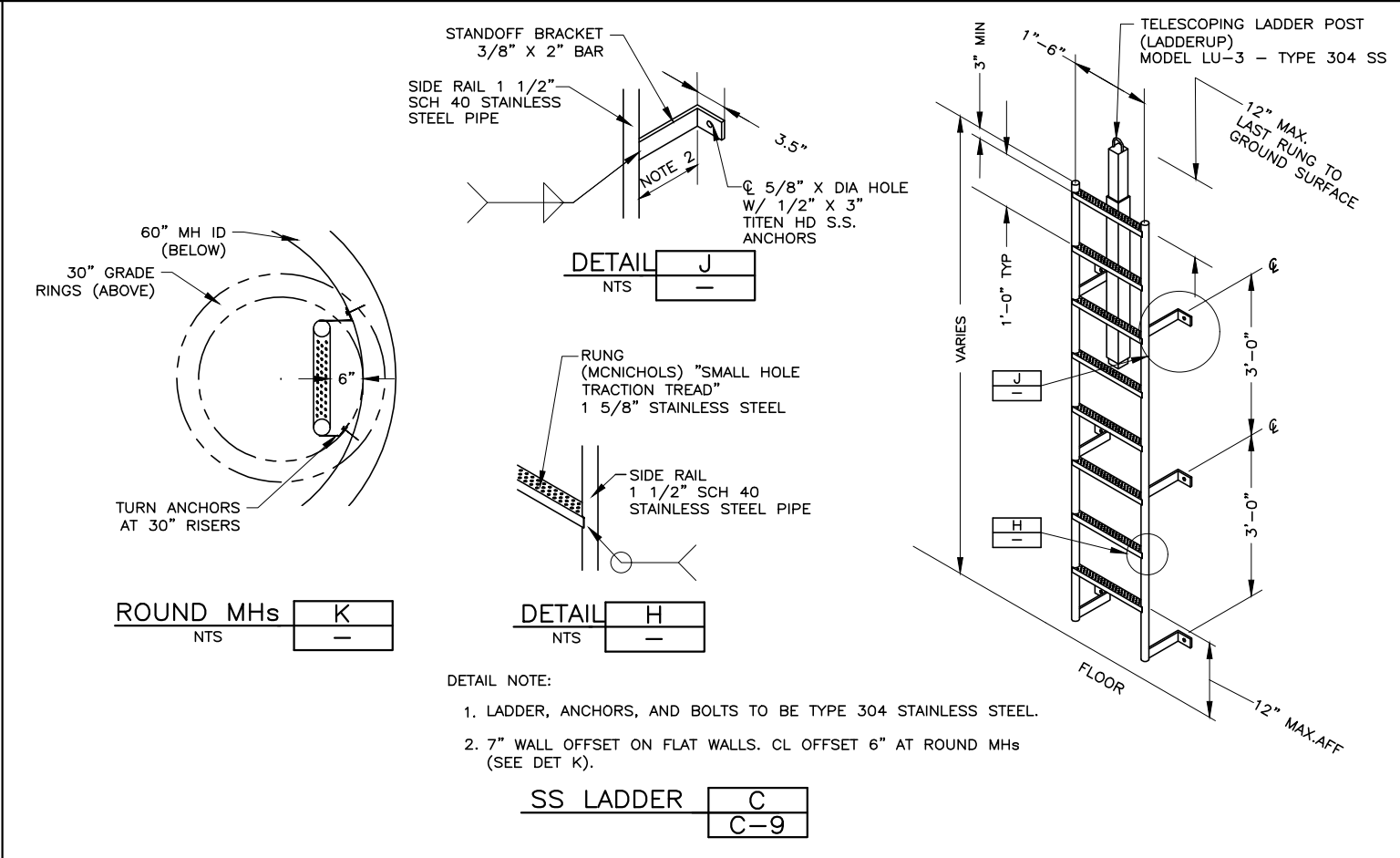
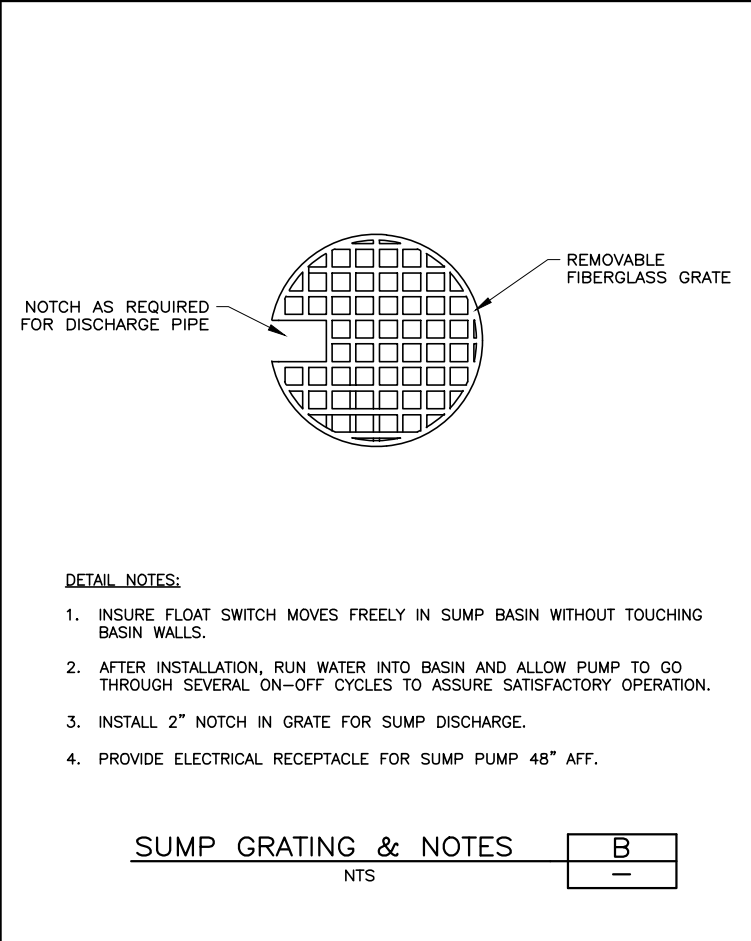

FILE NAME: PROJECTS\127 - JVVCD\42.100 - 2023-24 VAULTS IMPROVEMENT\CAD\C-16 TYPICAL DETAILS IV\_R1.DWG  
FILE DATE: 9/30/2024 12:45:41 (DD)

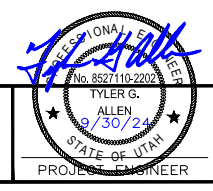

DESIGNED	NPJ	3
DRAFTED	DD	2
CHECKED	TGA	1
DATE	SEPTEMBER 2024	NO.

NO.	DATE	REVISIONS	BY	APVD.

SCALE  
NOT  
TO  
SCALE



2024 VAULT IMPROVEMENT PROJECT  
CIVIL  
TYPICAL DETAILS IV

SHEET  
C-16  
127.42.100



FILE NAME: PROJECTS\127 - JVVCD\42.100 - 2023-24 VAULTS IMPROVEMENT\CAD\C-17 TYPICAL DETAILS V.DWG  
 FILE DATE: 9/30/2024 12:48:57 (DD)

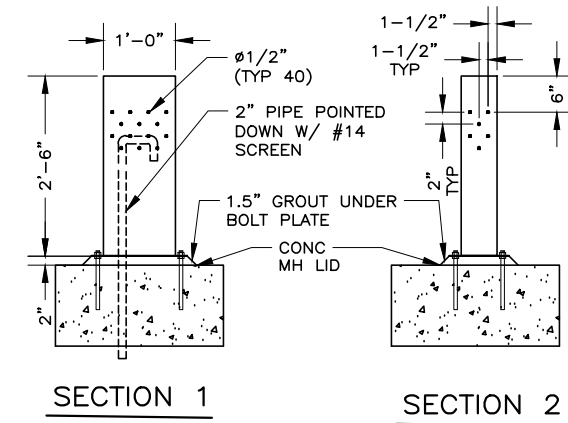
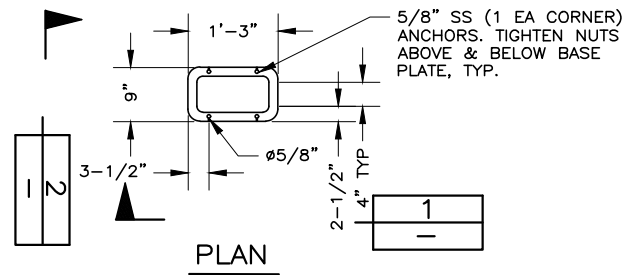

NOTE:  
 BASE, ROOF, & SIDE PLATES SHALL BE 3/16" THK SS.  
 JOIN ALL PLATES W/FULL LENGTH 3/16" SS FILLET WELDS.

VENT COVER	A	A
NTS	C-7	C-8



DESIGNED NPJ 3  
 DRAFTED DD 2  
 CHECKED TGA 1  
 DATE SEPTEMBER 2024 NO. DATE

NO.	DATE	REVISIONS	BY	APVD.

SCALE  
 NOT  
 TO  
 SCALE



2024 VAULT IMPROVEMENT PROJECT  
 CIVIL  
 TYPICAL DETAILS V

SHEET  
 C-17  
 127.42.100



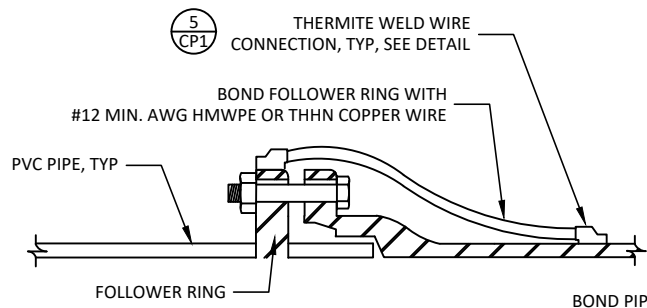

DETAIL A

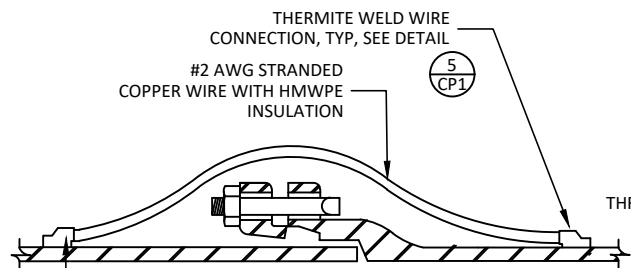

DETAIL B

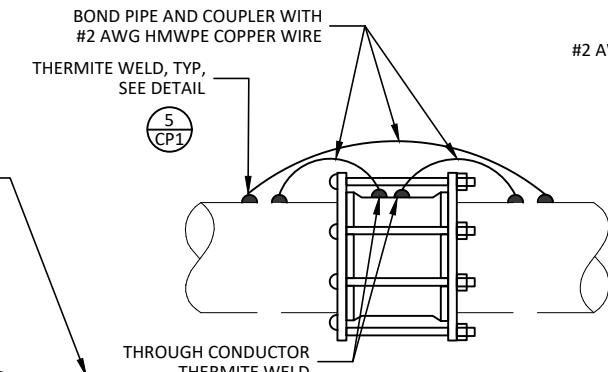

DETAIL C

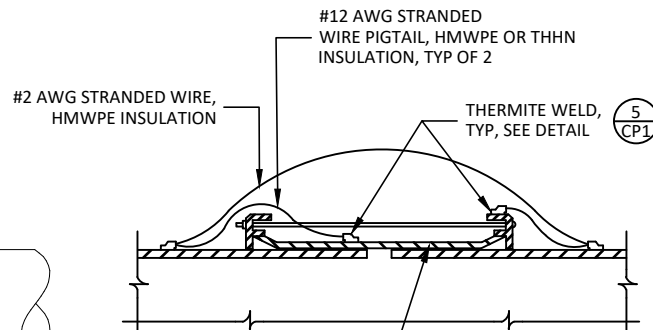

- NOTES:
1. INSTALL TWO (2) BOND WIRES PER JOINT.
  2. COAT ALL THERMITE WELDS, PIPE, AND EXPOSED COPPER WIRE WITH DENSO PROTAL (7125, 7200, 7300) OR COATING SYSTEM AS SPECIFIED.

**FLEXIBLE JOINT BOND**

NTS

2

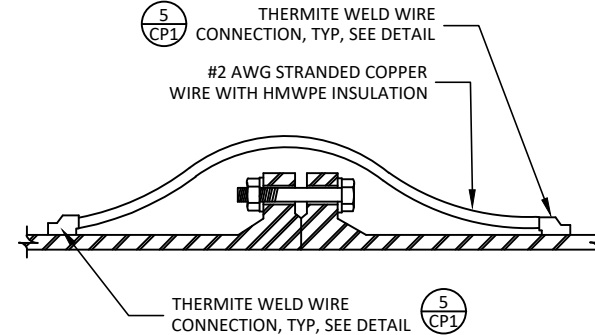

- NOTES:
1. INSTALL TWO (2) BOND WIRES PER JOINT.
  2. COAT ALL THERMITE WELDS, PIPE, AND EXPOSED COPPER WIRE WITH DENSO PROTAL (7125, 7200, 7300) OR COATING SYSTEM AS SPECIFIED.
  3. PIPELINE COATING NOT SHOWN FOR CLARITY.

**FLANGED JOINT BOND**

NTS

3

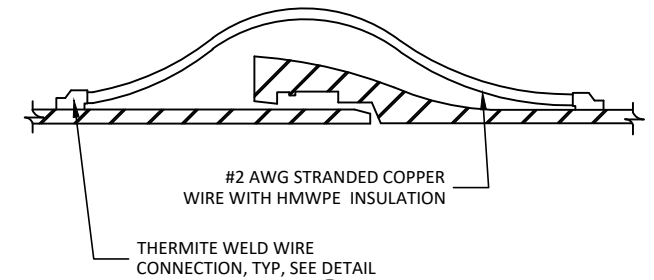

- NOTES:
1. PUSH ON DUCTILE IRON BOND SHOWN, SIMILAR FOR DUCTILE MECHANICAL AND RESTRAINED JOINTS, AND STEEL CARNEGIE JOINTS.
  2. INSTALL NUMBER OF BOND WIRES SPECIFIED PER JOINT FOR PIPE DIAMETER AND MATERIAL.
  3. COAT ALL THERMITE WELDS, PIPE, AND EXPOSED COPPER WIRE WITH DENSO PROTAL (7125, 7200, 7300) OR COATING SYSTEM AS SPECIFIED.
  4. PIPELINE COATING NOT SHOWN FOR CLARITY.

**DUCTILE IRON JOINT BOND**

NTS

4

**MECHANICAL JOINT BOND**

NTS

1

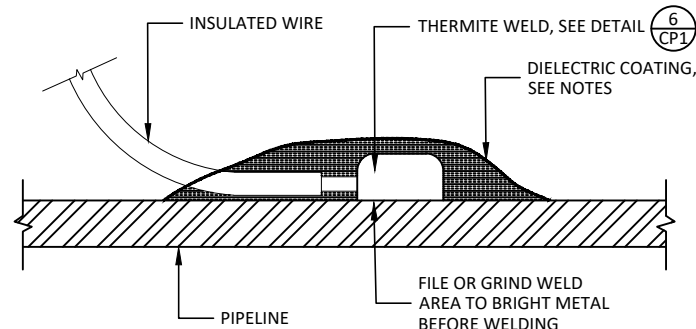

- NOTES:
1. COPPER SLEEVE REQUIRED FOR #2 AWG JOINT BONDS OR FOR #12 AWG OR SMALLER TEST WIRES.
  2. WELDER AND CARTRIDGE SIZE VARIES ACCORDING TO PIPE SIZE AND PIPE MATERIAL, CONSULT WELDER MANUFACTURER FOR RECOMMENDED WELDER AND CARTRIDGE.
  3. COAT ALL THERMITE WELDS, PIPE, AND EXPOSED COPPER WIRE WITH DENSO PROTAL (7125, 7200, 7300) OR COATING SYSTEM AS SPECIFIED.
  4. PIPELINE COATING NOT SHOWN FOR CLARITY.

**STEEL AND DUCTILE IRON PIPE WIRE CONNECTION**

NTS

5

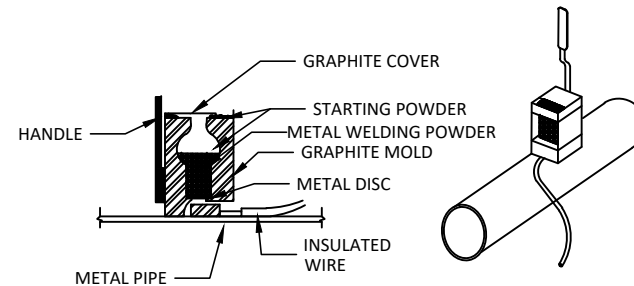

- STEP 1** FILE STRUCTURE CONNECTION AREA (3IN X 3IN) TO BARE SHINY METAL AND CLEAN.
- STEP 2** STRIP INSULATION FROM WIRE.
- STEP 3** HOLD MOLD FIRMLY WITH OPENING AWAY FROM OPERATOR AND IGNITE WITH STRIKER.
- STEP 4** REMOVE SLAG FROM CONNECTION AND PEEN WELD FOR SOUNDNESS.
- STEP 5** COVER CONNECTION AND EXPOSED STRUCTURE SURFACE WITH A DIELECTRIC COATING AS SPECIFIED.

**EXOTHERMIC WELD PROCEDURE**

NTS

6

**EXOTHERMIC WELD NOTES:**

1. ONE WELD SHALL BE USED FOR EACH.
2. CLEAN OILY OR GREASY CABLE WITH A RAPID-DRYING SOLVENT. REMOVE ONLY ENOUGH INSULATION FROM THE CABLE TO ALLOW THE EXOTHERMIC WELD CONNECTION TO BE MADE.
3. REMOVE ALL COATING, DIRT, GRIME, AND GREASE FROM THE METAL STRUCTURE AT WELD LOCATIONS BY WIRE BRUSHING AND/OR USE OF SUITABLE SAFE. SOLVENTS. CLEAN THE STRUCTURE TO A BRIGHT, SHINY SURFACE FREE OF ALL SERIOUS PITS AND FLAWS. THE AREA OF THE STRUCTURE WHERE THE ATTACHMENT IS TO BE MADE MUST BE DRY.
4. OPEN WELD MOLD AND PLACE METAL DISC INSIDE AT BOTTOM OF MOLD, POUR METAL WELDING POWDER INTO MOLD AND ON TOP OF METAL DISC. STARTING POWDER IS CAKED AT THE BOTTOM OF THE WELD CHARGE CONTAINER. TAP WELD CHARGE CONTAINER AND POUR HALF OF STARTING POWDER INTO WELD MOLD. CLOSE THE TOP OF WELD MOLD AND POUR THE REMAINING STARTING POWDER IN STRIKING HOLE. THE WELD MOLD IS NOW LOADED AND READY FOR USE.
5. PROVIDE PREFABRICATED FACTORY SLEEVES WHERE REQUIRED BY THERMITE WELDING MANUFACTURER.
6. THE LEAD WIRE IS TO BE HELD AT AN ANGLE TO THE SURFACE WHEN WELDING. ONLY ONE WIRE SHALL BE ATTACHED WITH EACH WELD. HOLD LOADED WELD MOLD FIRMLY ON PIPE AND WIRE. IGNITE STARTING POWDER IN STRIKING HOLE USING A STRIKER. HOLD WELD MOLD FIRMLY AGAINST PIPE FOR 5 SECONDS TO ALLOW FOR WELD PROCESS.
7. WELDS SHALL BE TESTED BY STRIKING THE WELD NUGGET WITH A TWO POUND HAMMER WHILE PULLING FIRMLY ON THE WIRE. ALL UNSOUND WELDS SHALL BE REMOVED, THE SURFACES RECLEANED, REWELDED, AND RETESTED. WELD SLAG SHALL BE REMOVED.
8. APPLY DIELECTRIC COATING AS SHOWN AND SPECIFIED TO WELD AND ALL EXPOSED AREAS SURROUNDING WELD.

90% DESIGN

FILE NAME: 7/04  
FILE DATE:



ERIK LLEWELLYN, PE  
PROJECT ENGINEER

DESIGNED	ESL	3	
DRAFTED	ZGS	2	
CHECKED	ESL	1	
DATE	JANUARY 2024	NO.	DATE

REVISIONS		BY	APVD.

SCALE  
NTS



2024 VAULT IMPROVEMENT PROJECT  
CATHODIC PROTECTION DETAILS

SHEET  
CP1

127.42.100



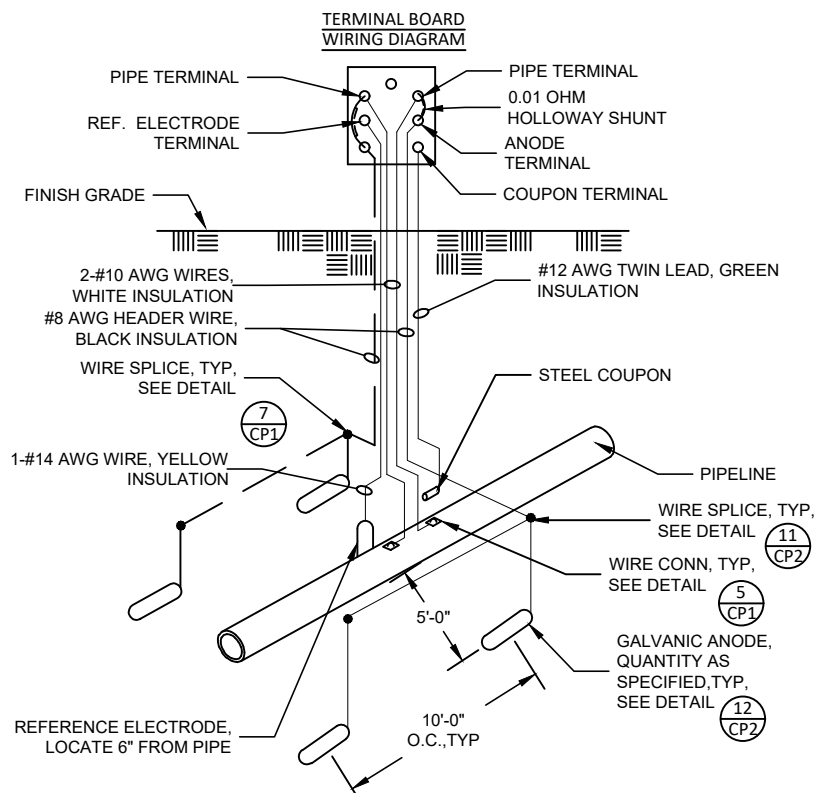

- NOTES:**
1. SEE POST TEST STATION DETAIL.
  2. POSITION STEEL COUPON 12" AND PARALLEL TO PIPE. COUPON SHOULD BE APPROX. 6" FROM REFERENCE ELECTRODE.
  3. INSTALL AND LABEL EACH TEST LEAD IN TEST STATION.
  4. NOT ALL TEST WIRES SHOWN FOR CLARITY. FOR TERMINAL BOARD LAYOUT, SEE DETAIL

**TYPE "A" TEST STATION** (7)

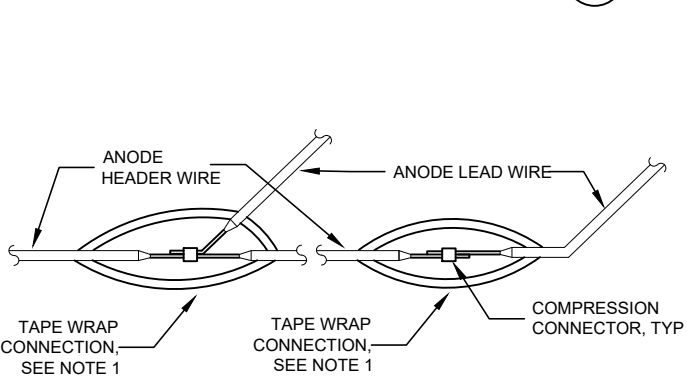

- NOTES:**
1. FILL VOIDS AND IRREGULARITIES WITH INSULATING PUTTY, WRAP CONNECTION WITH TWO LAYERS OF SCOTCH 130C SELF VULCANIZING RUBBER TAPE AND TWO LAYERS OF SCOTCH 88 VINYL ELECTRICAL TAPE.
  2. DETAIL SIMILAR FOR ANODE HEADER WIRE SPLICES, SIZE COMPRESSION CONNECTORS AS REQUIRED.

**GALVANIC ANODE WIRE SPLICES** (11)

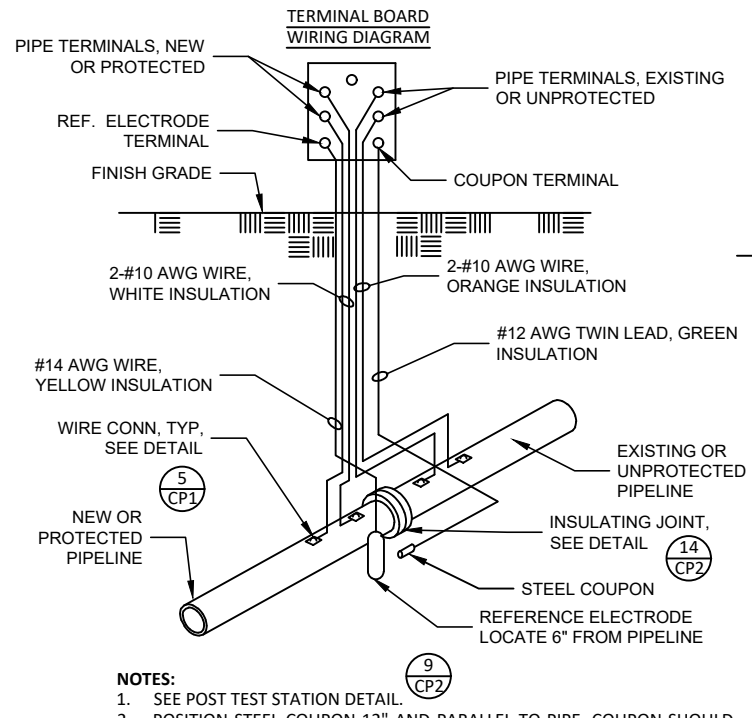

- NOTES:**
1. SEE POST TEST STATION DETAIL.
  2. POSITION STEEL COUPON 12" AND PARALLEL TO PIPE. COUPON SHOULD BE APPROX. 6" FROM REFERENCE ELECTRODE.
  3. INSTALL AND LABEL EACH TEST LEAD IN TEST STATION.
  4. NOT ALL TEST WIRES SHOWN FOR CLARITY. FOR TERMINAL BOARD LAYOUT, SEE DETAIL

**TYPE "I" TEST STATION** (8)

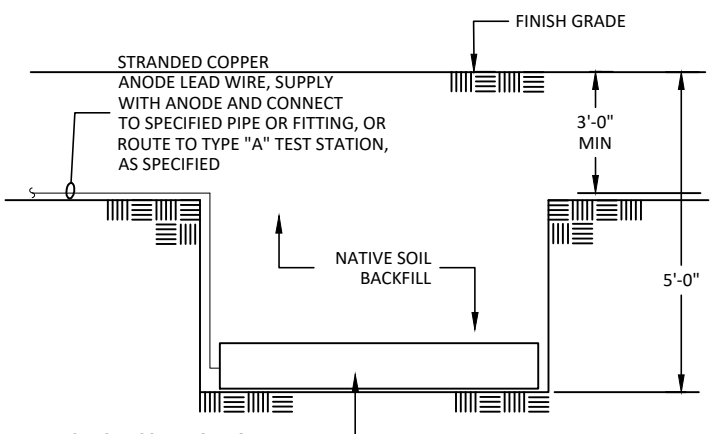

- NOTES:**
1. ANODES TO BE INSTALLED HORIZONTALLY UNLESS SPECIFIED OTHERWISE.
  2. ANODES INCLUDE AN ATTACHED LEAD WIRE FOR INSTALLATION.
  3. WHERE MULTIPLE ANODES ARE SPECIFIED TO BE INSTALLED, SPLICE ANODE LEAD WIRES TOGETHER AND RUN HEADER WIRE TO TEST STATION. SEE DETAILS
  4. REMOVE ANODE FROM PLASTIC BEFORE INSTALLATION.
  5. ENSURE ANODES ARE NOT IN CONTACT WITH ANY OTHER BELOW GRADE STRUCTURES.
  6. AFTER ANODE INSTALLATION, BACKFILL TO 1-FOOT OVER THE ANODES, WATER ANODES WITH 5 GALLONS OF WATER PER ANODE, IF SOILS ARE DRY AS DETERMINED BY THE ENGINEER.
  7. WHEN POSSIBLE, PLACE ANODES WITHIN MOIST LOAM AND CLAY SOIL. AVOID PLACEMENT OF ANODES WITHIN DRY SAND AND DO NOT PLACE WITHIN GRAVEL.

**HORIZONTAL GALVANIC ANODE INSTALLATION** (12)

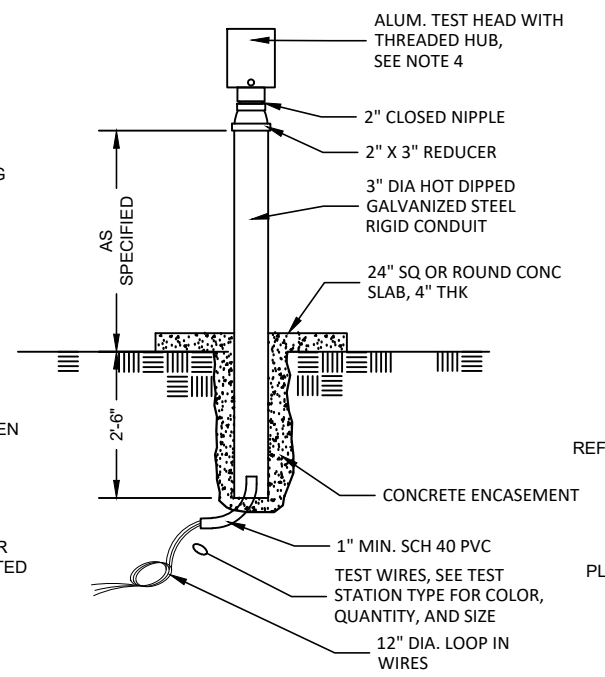

- NOTES:**
1. QUANTITY OF TERMINALS AND WIRING CONNECTIONS VARIES, SEE APPLICABLE TEST STATION DETAILS FOR TYPE OF TEST STATION.
  2. PROVIDE WIRE LOOP AT BASE OF POST MOUNTED TEST STATION TO MINIMIZE SETTLEMENT STRESSES ON WIRE.
  3. INSTALL TESTOX SERIES 700 TEST STATION UNLESS SPECIFIED OTHERWISE.
  4. CORROSION RESISTANT TAPE WRAP TO BE APPLIED TO BURIED SECTION OF GALVANIZED STEEL POST. EXTEND TAPE TO 6" ABOVE GROUND.

**POST MOUNTED, GALVANIZED STEEL POST** (9)

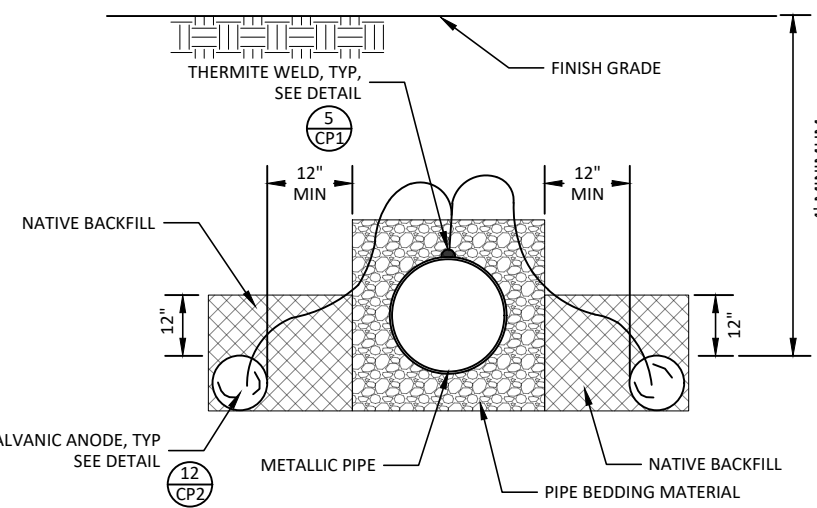

- NOTES:**
3. GALVANIC ANODES SHALL BE THE MATERIAL AND WEIGHT AS SPECIFIED.
  4. INSTALL QUANTITY OF ANODES AS SPECIFIED.
  5. WHERE MULTIPLE ANODES ARE INSTALLED, MAINTAIN 5' CENTER TO CENTER SEPARATION.
  6. COAT CONNECTION AND ANY EXPOSED METAL WITH WAX TAPE OR EPOXY, AS SPECIFIED.

**ANODE DIRECT CONNECTION** (13)

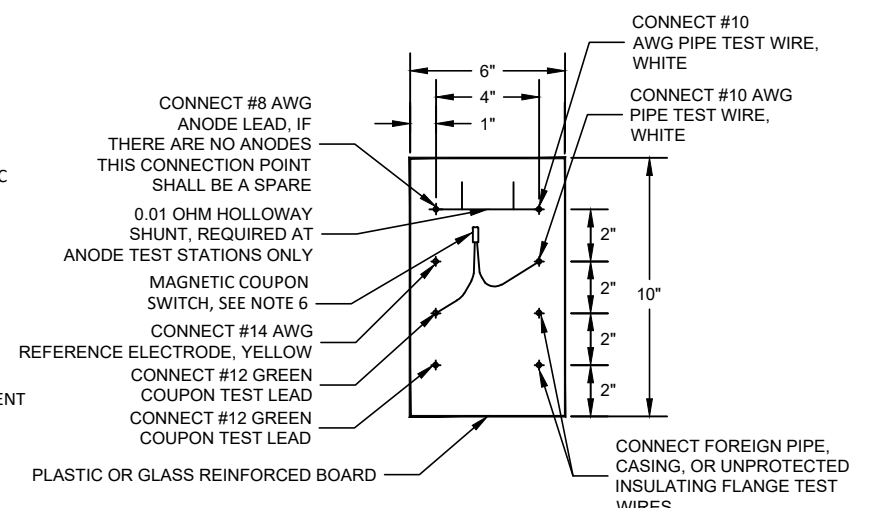

- NOTES:**
1. TERMINAL BOARD LAYOUT FOR REFERENCE ONLY AND MAY BE DIFFERENT ON PHYSICAL BOARD.
  2. TERMINALS SHALL BE 1/4" STAINLESS STEEL WITH LOCKING WASHER, TWO FLAT WASHERS, AND DOUBLE NUTS.
  3. ALL WIRE CONNECTIONS TO BE WITH RING TONGUE COMPRESSION TERMINALS.
  4. INSTALL AND LABEL EACH TEST LEAD IN TEST STATION.
  5. TEST WIRES NOT SHOWN FOR CLARITY.
  6. ONE (1) COUPON TO BE INSTALLED OR AS SPECIFIED BY ENGINEER WITH MAGNETIC COUPON SWITCH INSTALLED BETWEEN COUPON TEST LEAD TERMINAL AND PIPE TEST LEAD TERMINAL.

**TERMINAL BOARD LAYOUT** (10)

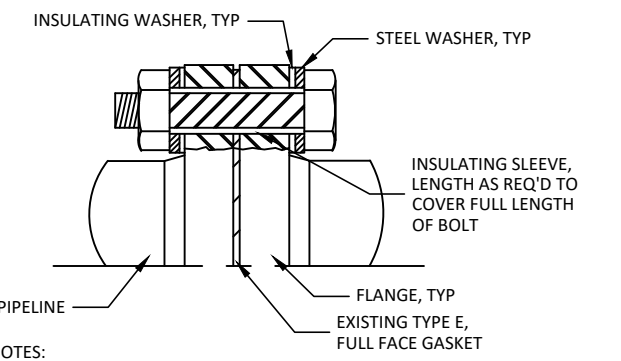

- NOTES:**
1. DOUBLE INSULATING WASHERS SHOWN FOR NON-BURIED INSULATING FLANGE INSTALLATIONS.
  2. FOR BURIED OR SUBMERGED INSULATING FLANGE INSTALLATION USE SINGLE INSULATING WASHER ON UNPROTECTED SIDE OF INSULATING FLANGE.
  3. COAT INTERIOR OF MORTAR LINED PIPE FOR TWO PIPE DIAMETERS WITH NSF APPROVED EPOXY AT 20 MILS DFT.
  4. COAT BURIED OR IMMERSED INSULATING FLANGES WITH SPECIFIED PIPELINE DIELECTRIC JOINT COATING OR HEAT SHRINK SLEEVE WITH MORTAR OVERCOAT ON MLC STEEL PIPE.
  5. TEST COMPLETED JOINT FOR ELECTRICAL ISOLATION AND REPAIR AS REQUIRED.

**INSULATING FLANGE** (14)

90% DESIGN

FILE NAME: 7/04  
FILE DATE:

	DESIGNED	ESL	3		
	DRAFTED	ZGS	2		
	CHECKED	ESL	1		
	PROJECT ENGINEER	DATE	JANUARY 2024	NO.	DATE

REVISIONS		BY	APVD.

SCALE	NTS

2024 VAULT IMPROVEMENT PROJECT CATHODIC PROTECTION DETAILS	SHEET CP2
---	--------------

127.42.100



STRUCTURAL NOTES

GENERAL NOTES:

1. THE GENERAL CONTRACTOR AND SUB-CONTRACTORS SHALL PROVIDE SUFFICIENT SKILLED WORKMEN AND SUPERVISORS WHO SHALL BE PRESENT AT ALL TIMES DURING EXECUTION OF THE WORK. A PROJECT MANAGER, SHALL BE ASSIGNED BY THE GENERAL CONTRACTOR, AND SHALL BE RESPONSIBLE FOR THE DAILY COORDINATION OF THE PROJECT AND SHALL MAINTAIN ALL REQUIRED DRAWINGS, SPECIFICATIONS, REPORTS, AND OTHER ITEMS FOR REVIEW AT THE SITE.
2. ALL CONSTRUCTION SHALL BE ACCORDING TO THE 2021 EDITION OF THE INTERNATIONAL BUILDING CODE (IBC). AS AMENDED BY THE STATE OF UTAH.
3. THE CONTRACTOR SHALL BE RESPONSIBLE FOR THE PROTECTION OF AND SAFETY IN AND AROUND THE JOB SITE AND/OR ADJACENT PROPERTIES.
4. THE CONTRACTOR AND/OR OWNER SHALL KEEP LOADS ON THE STRUCTURE WITHIN THE LIMITS OF THE DESIGN LOADS BOTH DURING AND AFTER CONSTRUCTION.

DESIGN CRITERIA

- |                                       |          |
|---------------------------------------|----------|
| 1. RISK CATEGORY:                     | IV       |
| 2. SNOW IMPORTANCE FACTOR, Is:        | 1.20     |
| 3. SEISMIC IMPORTANCE FACTOR, Ie:     | 1.50     |
| 4. GROUND SNOW LOAD Pg:               | 33 PSF   |
| 5. LIVE LOAD:                         | 60 PSF   |
| 6. HS20-44 LOADING (WHERE APPLICABLE) |          |
| 7. NO SOILS REPORT WAS PROVIDED:      |          |
| ASSUMED SOIL BEARING PRESSURE :       | 1500 PSF |
| COEFFICIENT OF FRICTION:              | 0.45     |
| AT-REST PRESSURE:                     | 60 PCF   |
| ACTIVE PRESSURE:                      | 45 PCF   |
| PASSIVE PRESSURE:                     | 250 PCF  |

STRUCTURAL NOTES:

REINFORCED CONCRETE:

1. ALL CONCRETE CONSTRUCTION, INCLUDING BENDING OF BARS, SHALL COMPLY WITH ACI "BUILDING CODE REQUIREMENTS FOR REINFORCED CONCRETE" (ACI 318).
2. UNLESS CALLED OUT OTHERWISE ON THE PLANS, MINIMUM REINFORCEMENT OF CONCRETE WORK SHALL BE:  
WALLS:  
8" THICK OR LESS - USE #5 @ 16" E.W.  
9" OR THICKER - USE #5 @ 12" E.W., E.F.  
SLABS:  
8" THICK OR LESS - USE #4 @ 16" E.W.
3. ALL WALL REINFORCEMENT AT CORNERS OR JUNCTIONS OF WALLS SHALL BE CONTINUOUS, LAPPED, OR TERMINATED IN A STANDARD 90 DEGREE HOOK. LAP SPLICES SHALL CONFORM WITH NOTE 6.
4. UNLESS SHOWN OTHERWISE ALL BARS SHALL BE DOWELED. DOWELS SHALL BE THE SAME SIZE AND SPACING AS THE REINFORCEMENT WHICH IS TO BE SPLICED TO THE DOWELS.
5. ALL REINFORCING BARS SHALL BE GRADE 60 AND SHALL CONFORM TO ASTM A-615, CURRENT REVISION. REINFORCING STEEL SHALL BE NEW AND FREE FROM RUST, OIL OR OTHER BOND INHIBITOR.
6. ALL CONTINUOUS REINFORCING BARS SHALL LAP AT LEAST 40 BAR DIAMETERS. SPLICES SHALL BE MADE AWAY FROM POINTS OF MAXIMUM STRESS. MINIMUM LAP SHALL BE 18 IN.
7. CONCRETE COVER OVER REINFORCEMENT SHALL BE AS FOLLOWS:  
7.1. SURFACE NOT EXPOSED DIRECTLY TO THE GROUND, WATER OR WEATHER AFTER FORM REMOVAL:  
    CONCRETE SLABS IN BUILDINGS - - - - - 3/4"  
7.2. CONCRETE SLABS IN WATER BEARING SURFACES EXPOSED DIRECTLY TO THE GROUND, WATER OR WEATHER AFTER FORM REMOVAL:  
    FOR #5 BARS OR SMALLER - - - - - 1-1/2"  
    FOR #6 BARS OR LARGER - - - - - 2"  
7.3. CONCRETE PLACED DIRECTLY AGAINST GROUND - - - - - 3"  
7.4. REINFORCEMENT SHALL BE PLACED WITHIN A TOLERANCE OF ±1/4" OF POSITION SPECIFIED.
8. CONCRETE CURING SHALL BE IN ACCORDANCE WITH THE CONTRACT DOCUMENTS. SOME CONCRETE WORK REQUIRES WATER CURING, AS MEMBRANE CURING IS NOT ALLOWED. THE CONTRACTOR IS WARNED THAT WATER CURING IS DIFFICULT AT TIMES DUE TO WIND AND DRY CONDITIONS. THE CONTRACTOR SHALL STUDY REQUIREMENTS AND SHALL FURNISH ADEQUATE SYSTEMS TO PROVIDE WATER CURING WHERE REQUIRED. TOP OF WALLS SHALL BE KEPT VISIBLY MOIST AT ALL TIMES AND SHALL BE FLOODED NOT LESS THAN THREE TIMES DAILY.  
A. FOR POURING CONCRETE DURING COLD WEATHER:  
1. FOLLOW RECOMMENDATIONS CONTAINED IN PUBLICATION ACI 306R "COLD-WEATHER CONCRETING," CURRENT REVISION.  
2. PROTECT CONCRETE WORK FROM PHYSICAL DAMAGE OR REDUCED STRENGTH WHICH COULD BE CAUSED BY FROST, FREEZING ACTIONS OR LOW TEMPERATURES.  
3. WHEN AIR TEMPERATURE HAS FALLEN TO OR IS EXPECTED TO FALL BELOW 40°F OR 4°C, UNIFORMLY HEAT WATER AND AGGREGATES BEFORE MIXING TO OBTAIN A CONCRETE MIXTURE TEMPERATURE OF NOT LESS THAN 50°F OR 10°C, AND NOT MORE THAN 80°F OR 27°C AT TIME OF PLACEMENT. CONCRETE SHALL BE AIR ENTRAINED WITH AIR CONTENT OF 6% +/- 1% BY VOLUME.

REINFORCED CONCRETE CONT.

4. CONCRETE SHALL BE AIR ENTRAINED WITH AIR CONTENT OF 6% +/- 1% BY VOLUME.
  5. DO NOT USE FROZEN MATERIALS OR MATERIALS CONTAINING ICE OR SNOW. DO NOT PLACE CONCRETE ON FROZEN SUBGRADE OR ON SUBGRADE CONTAINING FROZEN MATERIALS.
  6. DO NOT USE CALCIUM CHLORIDE, SALT OR OTHER MATERIALS CONTAINING ANTIFREEZE AGENTS OR CHEMICAL ACCELERATORS, UNLESS OTHERWISE APPROVED IN THE MIX DESIGN.
  7. COVER AND HEAT CONCRETE FOR A MINIMUM OF 7 DAYS AS RECOMMENDED BY ACI 306R, CURRENT REVISION.
- B. FOR POURING CONCRETE DURING HOT WEATHER:  
FOLLOW RECOMMENDATIONS CONTAINED IN PUBLICATION ACI 305R "COLD-WEATHER CONCRETING," CURRENT REVISION.  
PROTECT CONCRETE FROM FLASH CURING BY PROVIDING A WATER/MOISTURE CURE FOR 3 DAYS.  
A 4500 PSI (WITH A 6-1/2 BAG MIX) IS RECOMMENDED FOR THESE CONDITIONS.
9. NO BACKFILL SHALL BE PLACED AGAINST WALLS UNTIL CONCRETE HAS REACHED 85 PERCENT OF THE SPECIFIED STRENGTH AND THE CONNECTING SLABS AND BEAMS HAVE BEEN CAST AND HAVE REACHED 85 PERCENT OF THE SPECIFIED STRENGTH.
  10. CONCRETE TO HAVE A MIN. 28 DAY STRENGTH OF 4000 PSI AND SHALL COMPLY WITH SANDY CITY SPECIFICATION: "SECTION 03000 - CONCRETE WORK".

WELDING

1. WELDS SHALL CONFORM TO AMERICAN WELDING SOCIETY (AWS), LATEST EDITION:  
D1.1, STRUCTURAL WELDING CODE - STEEL  
D1.2, STRUCTURAL WELDING CODE - ALUMINUM  
D1.3, STRUCTURAL WELDING CODE - SHEET STEEL  
D1.4, STRUCTURAL WELDING CODE - REINFORCING STEEL  
D1.6, STRUCTURAL WELDING CODE - STAINLESS STEEL
2. REPAIR WELDS FOUND DEFECTIVE IN ACCORDANCE WITH AWS D1.1, SEC 5.26.
3. USE INTERMITTENT WELDS AT FIELD WELDS OF EMBED PLATES AND ANGLES TO AVOID SPALLING OR CRACKING OF THE EXISTING CONCRETE.

SUBMITTALS:

1. THE FOLLOWING INFORMATION AND SUBMITTALS SHALL BE PROVIDED TO THE CONSTRUCTION MANAGER (CM) BEFORE FABRICATION AND/OR DELIVERY TO THE JOBSITE, NOT ALL MAY APPLY.  
A. CONCRETE MIX DESIGNS.  
B. CONCRETE REINFORCEMENT SHOP DRAWINGS.  
C. STRUCTURAL BACKFILL PIT LOCATION AND MATERIAL SPECIFICATION, IF USED ON SITE.  
D. STRUCTURAL STEEL SHOP DRAWINGS.  
E. OTHER SHOP DRAWINGS & SUBMITTALS AS DEEMED NECESSARY BY THE CONSTRUCTION MANAGER.

FILE NAME: PROJECTS\127 - JWC\042.100 - 2023-24 VAULTS IMPROVEMENT\CAD\S-1 STRUCTURAL NOTES.DWG  
FILE DATE: 9/30/2024 12:52:04 (DD)



DESIGNED NPJ,RCC	3				
DRAFTED DD	2				
CHECKED TGA	1				
DATE SEPTEMBER 2024	NO.	DATE	REVISIONS	BY	APVD.

SCALE



2024 VAULT IMPROVEMENT PROJECT  
STRUCTURAL  
STRUCTURAL NOTES

SHEET  
S-1  
127.42.100



SPECIAL INSPECTIONS

SCHEDULE OF SPECIAL INSPECTIONS APPLICABLE TO THIS PROJECT					
MATERIAL/ACTIVITY	TYPE OF INSPECTION	C/P *	EXTENT/REFERENCE	INSP INITIALS	INSP DATE
<b>GENERAL</b>					
Pre-construction conference	Meeting with Owner, Contractor and Registered Design Professional to discuss Special Inspection procedures	P	Scheduled by DCRA with the Contractor prior to commencement of work		
<b>EARTHWORK</b>					
Site preparation (building)	Field testing and inspection	P	Field Review; IBC 1705.6		
Fill material (building)	Review submittals, field testing and inspection	P	Field Review; IBC 1705.6		
Fill compaction (building)	In-place density tests, lift thickness	C	Field Review; IBC 1705.6		
Excavation	Field inspection and verification of proper depth	P	Field Review; IBC 1705.6		
Foundation sub-grade	Field inspection of foundation subgrade prior to placement of concrete	P	Field Review; IBC 1705.6		
<b>CONCRETE</b>					
Materials	Review product supplied versus certificates of compliance and mix design	P	Submittal & Field Review; IBC 1705.3; ACI 318: Ch. 4 and 5; IBC 1904.2, 1910.2, 1903.3		
Installation of reinforcing steel, including Pre-stressed tendons and anchor bolts as well as welding	Field inspection of placement	P	Submittal and Field Review; ACI 318:3.5, 3.5.2 3.8.6 & Ch. 7 8.1.3 and 21.2.8; AWS D1.4; IBC 1705.3, 1908.5, 1909.1, 1910.4		
Formwork installation	Field inspection	P	Field Review; ACI 318: 6.1.1; IBC 1705.3		
Concreting operations and placement	Field inspection of placement/sampling	C	Field Review; ACI 318: 5.6, 5.8, 5.9-10; ASTM C 172, C 31; IBC 1705.3, 1910.6, 1910.7, 1910.8, 1910.10		
Concrete curing	Field inspection of curing process	P	Field Review; ACI 318: 5.11-13; IBC 1705.3, 1910.9		
Concrete strength	Evaluation of concrete strength		Laboratory Testing; ACI 318: 6.2; IBC 1705.3		
<b>PRECAST CONCRETE</b>					
Verify fabrication/QC procedures In-plant	Inspection of plant and QC procedures**		Submittal or Field Review; IBC 1705.3		
Erection and installation	Review submittals and as-built assemblies; Field inspection of in-place precast		Submittal and Field Review; ACI 318; Ch. 16; IBC Table 1705.3		

NOTES:

1. THE SPECIAL INSPECTOR IS RESPONSIBLE FOR ENSURING THE PUBLICATIONS USED FOR INSPECTION CRITERIA ARE THE MOST CURRENT AND UP TO DATE.
2. FAILURE OF INSPECTABLE AREAS ARE TO BE NOTED AND SUBMITTED TO THE OWNER, ENGINEER OF RECORD, AND GENERAL CONTRACTOR IF CORRECTIONS REQUIRE A FOLLOW UP INSPECTION AND CANNOT BE MADE COMPLETED "ON THE SPOT".
3. DOCUMENTATION FOR INSPECTIONS MUST BE COMPLETED AND SUBMITTED IN ACCORDANCE WITH CONTRACT REQUIREMENTS, INTERNATIONAL BUILDING CODE (LATEST EDITION), AND "MANUAL FOR SPECIAL INSPECTIONS" (LATEST EDITION), OR AS AGREED UPON WITH THE OWNER, ENGINEER OF RECORD, AND CONTRACTOR.
4. SPECIAL INSPECTION DOES NOT INCLUDE OR WAIVE THE RESPONSIBILITY FOR ANY REQUIRED INSPECTIONS BY THE BUILDING OFFICIAL. CONTRACTOR IS RESPONSIBLE FOR SCHEDULING BOTH INSPECTIONS.
5. SPECIFIED CONCRETE AND MASONRY TESTING DURING CONSTRUCTION WILL BE CONTRACTOR FURNISHED. SPECIFIED LAB TEST, MIXES, AND SIMILAR TESTING TO VERIFY MATERIAL QUALITY AND CONFORMANCE TO THE SPECIFICATIONS, REQUIRING SUBMITTAL FOR REVIEW AND ACCEPTANCE, SHALL BE THE RESPONSIBILITY OF THE CONTRACTOR.
6. STRUCTURAL OBSERVATIONS (CONTRACTOR FURNISHED) IS REQUIRED IN ACCORDANCE WITH IBC SECTION 110 AND CHAPTER 17 AS INDICATED IN THE STATEMENT OF SPECIAL INSPECTION.

P = PERIODIC INSPECTION  
C = CONTINUOUS INSPECTION

FILE NAME: PROJECTS\127 - JWWCD\42.100 - 2023-24 VAULTS IMPROVEMENT\CAD\S-2 SPECIAL INSPECTIONS.DWG  
FILE DATE: 9/30/2024 12:58:05 (DD)

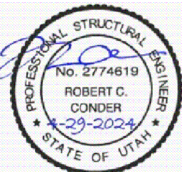

DESIGNED	NPJ,RCC	3	
DRAFTED	DD	2	
CHECKED	TGA	1	
DATE	SEPTEMBER 2024	NO.	DATE

NO.	DATE	REVISIONS	BY	APVD.

SCALE  
NOT  
TO  
SCALE



2024 VAULT IMPROVEMENT PROJECT  
STRUCTURAL  
SPECIAL INSPECTIONS

SHEET  
S-2  
127.42.100



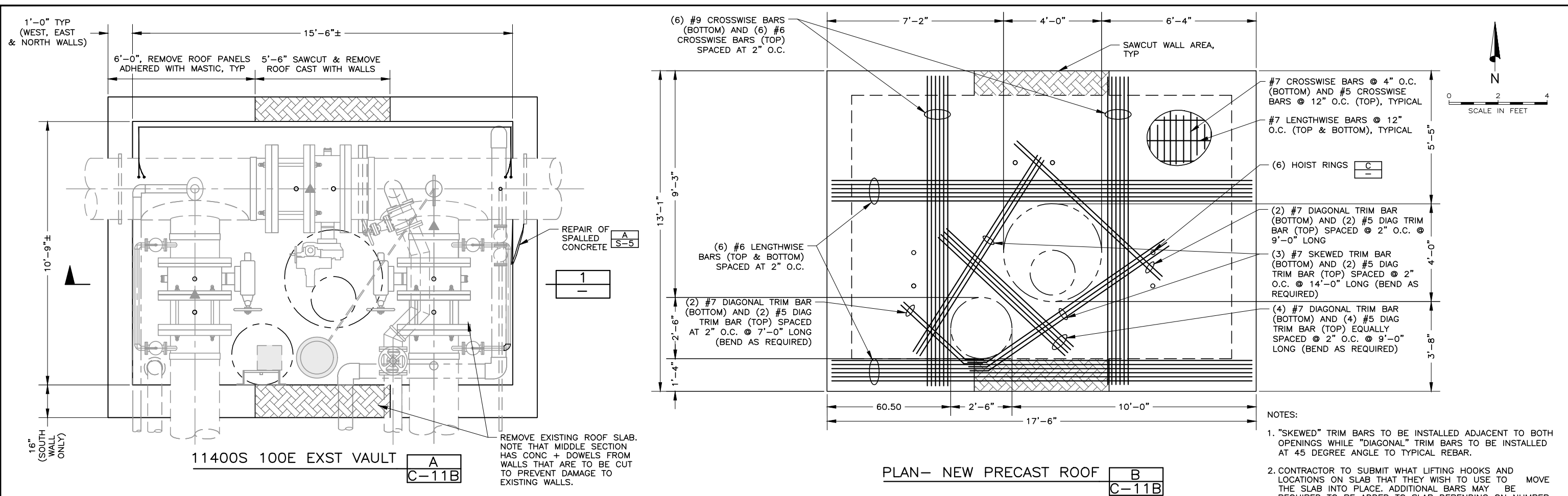

- NOTES:
- "SKEWED" TRIM BARS TO BE INSTALLED ADJACENT TO BOTH OPENINGS WHILE "DIAGONAL" TRIM BARS TO BE INSTALLED AT 45 DEGREE ANGLE TO TYPICAL REBAR.
  - CONTRACTOR TO SUBMIT WHAT LIFTING HOOKS AND LOCATIONS ON SLAB THAT THEY WISH TO USE TO MOVE THE SLAB INTO PLACE. ADDITIONAL BARS MAY BE REQUIRED TO BE ADDED TO SLAB DEPENDING ON NUMBER OF HOOKS TO BE USED AND THEIR PROPOSED LOCATIONS.

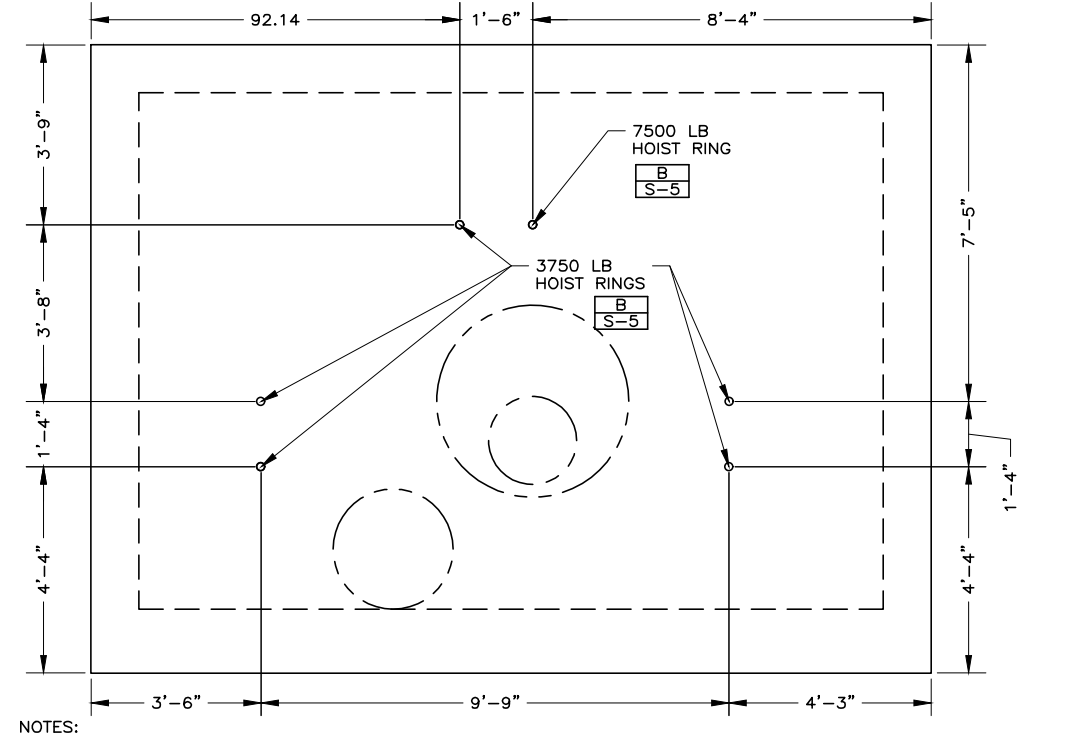
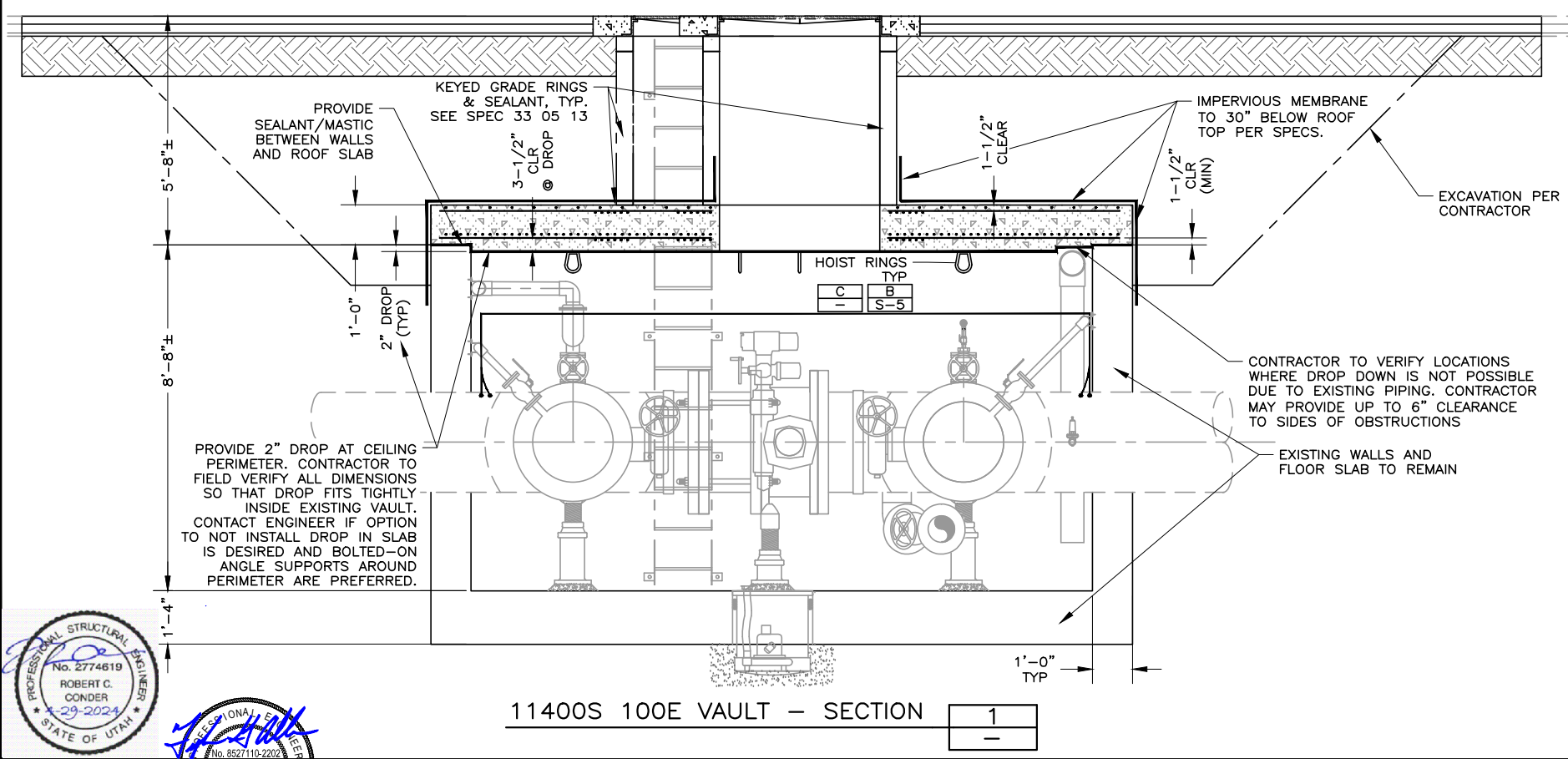

- NOTES:
- SLAB LIFTING HOOK(S) FOR CONSTRUCTION NOT SHOWN. CRANE OR VEHICLE IS TO NOT BE LOCATED DIRECTLY OVER OR NORTH/SOUTH OF SLAB WHILE HOIST RINGS ARE BEING USED TO PREVENT OVERLOADING OF ROOF SLAB. CRANE MAY BE LOCATED TO SIDES (EAST/WEST) WHEN HOIST RINGS ARE IN USE.

FILE NAME: PROJECTS\127-JVWCD\42.100 - 2023-24 VAULTS IMPROVEMENT\CAD\S-3 VAULT 11400S\_100E.DWG  
 FILE DATE: 9/30/2024 12:59:34 (DD)

ROBERT C. CONDER  
 No. 2774619  
 STATE OF UTAH  
 29-2024

DESIGNED NPJ	3			
DRAFTED DD	2			
CHECKED TGA	1			
DATE SEPTEMBER 2024	NO.	DATE	REVISIONS	BY APVD.

SCALE AS SHOWN  

 JORDAN VALLEY WATER CONSERVANCY DISTRICT  
 2024 VAULT IMPROVEMENT PROJECT STRUCTURAL  
 11400 SOUTH 100 EAST - VAULT ROOF  
 SHEET S-3  
 127.42.100



FILE NAME: PROJECTS\127 - JWVCD\42.100 - 2023-24 VAULTS IMPROVEMENT\CAD\S-5 VAULT ROOF DETAILS.DWG  
 FILE DATE: 9/30/2024 12:56:10 (DD)

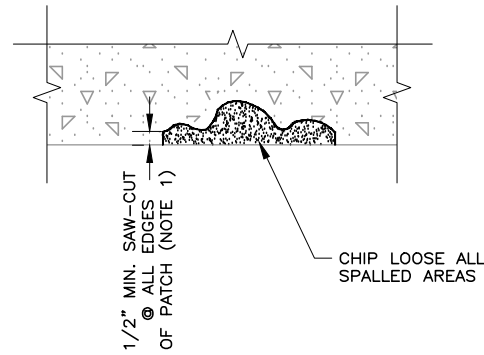

PATCH REPAIR NOTES:

1. SAW CUT EDGES OF PATCHES TO PROVE CLEAN EDGES (AND TO PREVENT FEATHERING OF PATCH MATERIALS). SPECIAL CARE IS TO BE TAKEN TO PREVENT CUTTING OR NOTCHING OF ANY REINFORCEMENT.
2. PREPARE SURFACE PER BONDING AGENT/GROUT MANUFACTURER.
3. PREPARE SURFACE & REINFORCEMENT W/ SIKA ARMATEC 110 EPOCEM & THEN INSTALL SIKATOP 123 PLUS, PER MANUFACTURER.
4. IF ALTERNATE PATCH MATERIAL IS TO BE USED, THEN A RUST INHIBITOR (SUCH AS SIKA FERROGAR-908) IS TO BE USED. PROVIDE ENGINEER W/ SPECIFICATIONS FOR ALTERNATES IF THEY ARE TO BE USED.

CONCRETE REPAIR DETAIL 

A
S-3

  
NTS

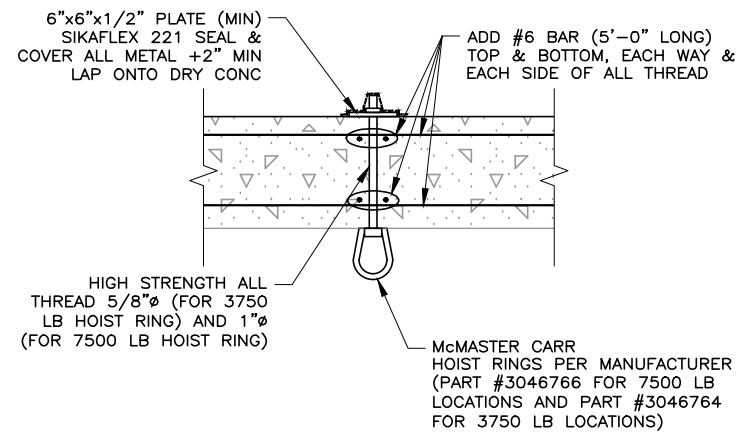

NOTES:

1. PLATE MAY BE COMBINED W/ ANOTHER PLATE WHERE (2) HOIST RINGS ARE CLOSE TOGETHER. PROVIDE MIN AREA OF 36 SQUARE INCHES OF PLATE FOR EACH HOIST RING.

HOIST RING 

B
S-3

  
NTS

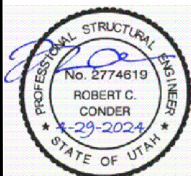

DESIGNED	NPJ	3
DRAFTED	DD	2
CHECKED	TGA	1
DATE	SEPTEMBER 2024	NO. DATE

NO.	DATE	REVISIONS	BY	APVD.

SCALE  
AS SHOWN



2024 VAULT IMPROVEMENT PROJECT  
STRUCTURAL  
VAULT ROOF DETAILS

SHEET  
S-5  
127.42.100



POWER ONE-LINE SYMBOLS		THIS IS A STANDARD LEGEND NOT ALL SYMBOLS MAY BE USED ON THIS PROJECT	
	ANTENNA		UTILITY METERING SOCKET WITH CIRCUIT BREAKER
	EQUIPMENT GROUND CONNECTION		EXISTING UTILITY METERING SOCKET
	TRANSFER SWITCH ATS: AUTOMATIC TRANSFER SWITCH MTS: MANUAL TRANSFER SWITCH		UTILITY METERING SOCKET
	VARIABLE FREQUENCY DRIVE MOTOR CONTROLLER		FUTURE UTILITY METERING SOCKET
	FUSED DISCONNECT SWITCH		UTILITY METERING CURRENT TRANSFORMER
	NON-FUSED DISCONNECT SWITCH		MOTOR STARTER
	COMBINATION STARTER		SURGE PROTECTOR
	MAGNETIC CONTROLLER		TRANSFORMER
	MOTOR (HP SHOWN)		FUSED SWITCH
	GENERATOR		FUSE IN HOLDER
	CONDUCTOR WITH CALLOUT REFERENCE (SEE CONDUIT/CONDUCTOR SCHEDULE)		EXISTING POWER DISTRIBUTION PANEL
	POWER FACTOR CAPACITOR		POWER DISTRIBUTION PANEL
	CIRCUIT BREAKER		FUTURE POWER DISTRIBUTION PANEL
	POWER FEED		
	CONNECTION POINT		
	LUG		
	DELTA WYE		

GENERAL DRAWING SYMBOLS		THIS IS A STANDARD LEGEND NOT ALL SYMBOLS MAY BE USED ON THIS PROJECT	
	REFERENCE NOTE		DEMOLITION NOTE
	REVISION NOTE		IDENTIFICATION NOTE
	PHOTO REFERENCE		EQUIPMENT REFERENCE
	WIRE SIZE REFERENCE		PHOTO REFERENCE
	SECTION/ELEVATION REFERENCE		

WIRING DEVICES		THIS IS A STANDARD LEGEND NOT ALL SYMBOLS MAY BE USED ON THIS PROJECT	
	20 AMP RATED RECEPTACLE SINGLE STROKE = SINGLE DOUBLE STROKE = DUPLEX RECEPTACLE MODIFIERS: X-X = CIRCUIT NUMBER AF = ARK FAULT CIRCUIT INTERRUPTER S = SURFACE MOUNTED IG = ISOLATED GROUND WP = WEATHER PROOF		EXISTING RECEPTACLE
	220V RECEPTACLE		GFCI RECEPTACLE
	ELECTRICAL CONNECTION		JUNCTION BOX
	PHOTOELECTRIC CONTROL UNIT		THERMOSTAT LOCATION
	CARD READER (ENTRY KEY PAD)		

CONTROL ONE-LINE SYMBOLS		THIS IS A STANDARD LEGEND NOT ALL SYMBOLS MAY BE USED ON THIS PROJECT	
	ENCLOSURE OR CONTROL PANEL		HOME RUN TO POWER PANEL "A" CIRCUIT "XX"
	LIGHT A: AMBER LENS G: GREEN LENS R: RED LENS W: WHITE LENS		COMBINATION MOTOR STARTER F: FUSED BLANK: CIRCUIT BREAKER
	EQUIPMENT IDENTIFICATION TAG		ELECTRICAL CONNECTION POINT
	SINGLE RECEPTACLE		

PLAN SYMBOLS		THIS IS A STANDARD LEGEND NOT ALL SYMBOLS MAY BE USED ON THIS PROJECT	
	CIRCUIT DISTRIBUTION PANELBOARD SURFACE MOUNTED		CIRCUIT DISTRIBUTION PANELBOARD RECESSED
	POWER DISTRIBUTION PANELBOARD SURFACE OR FLOOR MOUNTED DOORS DESIGNATE FRONT OF PANEL MDP DESIGNATES MAIN DISTRIBUTION PANEL		CONTROL PANEL ENCLOSURE
	LIGHTING CONTROL PANEL		DISCONNECT
	COMBO STARTER/DISCONNECT		

LIGHT SWITCHES		THIS IS A STANDARD LEGEND NOT ALL SYMBOLS MAY BE USED ON THIS PROJECT	
	SINGLE POLE SWITCH		GANGED SWITCHES IN COMMON BOX WITH COMMON COVER PLATE
	SWITCH SUPERScript MODIFIER, LOWER CASE LETTER INDICATES CIRCUIT CONTROLLER -- a,b,c ETC. MAY BE COMBINED WITH CIRCUIT NUMBER. EXAMPLE: 1a, 3b		SWITCH SUBSCRIPT MODIFIER, UPPER CASE LETTER OR NUMBER:  2 = DOUBLE POLE 3 = THREE WAY 4 = FOUR WAY K = KEY OPERATED M = HORSEPOWER RATED MANUAL STARTER MC = MOMENTARY CONTACT, THREE POSITION MS = MANUAL (STARTER) OR SWITCH D = DIMMER S = SURFACE F = FLUSH

POWER ONE-LINE SYMBOLS		THIS IS A STANDARD LEGEND NOT ALL SYMBOLS MAY BE USED ON THIS PROJECT	
	EXISTING POWER FEED		EXISTING UTILITY METERING SOCKET
	EQUIPMENT GROUND CONNECTION		CONDUCTOR WITH CALLOUT REFERENCE (SEE CONDUIT/CONDUCTOR SCHEDULE)
	POWER DISTRIBUTION PANEL		GROUND ROD (3/4" x 10' COPPER COATED STEEL)
	CIRCUIT BREAKER		CONNECTION POINT

LIGHTING SYMBOLS		THIS IS A STANDARD LEGEND NOT ALL SYMBOLS MAY BE USED ON THIS PROJECT	
	DESIGNATES FIXTURE NUMBER - REFER TO FIXTURE SCHEDULE		PHOTOCELL
	LED FIXTURES		SURFACE OR RECESSED 1X4 FIXTURE
	EXTERIOR LIGHTS		WALL PAK FIXTURE

HVAC EQUIPMENT		THIS IS A STANDARD LEGEND NOT ALL SYMBOLS MAY BE USED ON THIS PROJECT	
	UNIT HEATER, WALL MOUNTED		UNIT HEATER, CEILING MOUNTED
	CONDENSING UNIT, PAD MOUNTED, SIDE DISCHARGE		CONDENSING UNIT, PAD MOUNTED, UP FLOW

GROUNDING SYMBOLS		THIS IS A STANDARD LEGEND NOT ALL SYMBOLS MAY BE USED ON THIS PROJECT	
	GROUND ROD (3/4" x 10' COPPER COATED STEEL) IN WELL		BOLTED GROUND CONNECTION (ABOVE GROUND)
	WELDED GROUND CONNECTION (BELOW GRADE)		GROUND CONDUCTOR

MOTOR AND EQUIPMENT		THIS IS A STANDARD LEGEND NOT ALL SYMBOLS MAY BE USED ON THIS PROJECT	
	MOTOR (HP SHOWN)		FRACTIONAL HORSEPOWER MOTOR
	MOTOR STARTER, INDIVIDUAL, NOT LOCATED IN A MOTOR CONTROL CENTER (MCC) OR SIMILAR GROUP ASSEMBLY		COMBINATION MOTOR STARTER ASSEMBLY, NOT LOCATED IN AN MCC OR SIMILAR ASSEMBLY
	MAGNETIC CONTACTOR ASSEMBLY, NOT LOCATED IN AN MCC OR SIMILAR ASSEMBLY		DISCONNECT, NON-FUSED, 3 POLE, 100A RATED
	FUSED DISCONNECT SWITCH		FIELD CONNECTION OR ELECTRICAL TERMINATION AT A FIELD DEVICE
	EQUIPMENT DESIGNATION		

CONDUIT AND RACEWAYS		THIS IS A STANDARD LEGEND NOT ALL SYMBOLS MAY BE USED ON THIS PROJECT	
	RACEWAY OR WIRING SYSTEM IN OR UNDER FLOOR OR CONCEALED IN WALL OR BEHIND STRUCTURE OR EQUIPMENT ENCASUREMENT		FLEX CONDUIT
	RACEWAY OR WIRING SYSTEM ABOVE FLOOR LEVEL BELOW CEILING, EXPOSED		HOMERUN: DESIGNATIONS INDICATE A ONE-LINE DIAGRAM OR PANELBOARD SCHEDULE REFERENCE
	JUNCTION BOX		RACEWAY OR WIRING SYSTEM TURNED TOWARD THE VIEWER (UP ON PLAN DRAWINGS)
	RACEWAY OR WIRING SYSTEM TURNED AWAY FROM THE VIEWER (DOWN ON PLAN DRAWINGS)		RACEWAY OR WIRING SYSTEM CHANGE IN ELEVATION OR DISTANCE FROM VIEWER
	CONDUIT STUB AND CAP		

H.P.E. INC. ELECTRICAL ENGINEERS  
POWER SYSTEMS, CONTROL & INSTRUMENTATION SYSTEMS  
HEGERHORST POWER ENGINEERING INCORPORATED (801) 642-2051  
708 EAST 50 SOUTH AMERICAN FORK, UT 84003 FAX (801) 642-2154  
HPE PROJECT: 23.066 ©2023  
FOR INFORMATION ABOUT THIS JOB, PLEASE CONTACT: KEITH HEGERHORST

- ### GENERAL NOTES
- VERIFY ALL EQUIPMENT DIMENSIONS AND LOCATIONS BEFORE BEGINNING ROUGH-IN. CONSULT ALL APPLICABLE CONTRACT DRAWINGS AND SHOP DRAWINGS TO ENSURE NEC CODE CLEARANCE REQUIRED AROUND ALL ELECTRICAL EQUIPMENT.
  - CONTRACTOR SHALL VERIFY ALL ELECTRICAL LOADS (VOLTAGE, PHASE, CONNECTION REQUIREMENTS, ETC.) OF EQUIPMENT FURNISHED BEFORE BEGINNING ROUGH-IN.
  - SEE APPLICABLE SHOP DRAWINGS FOR ROUGH-IN LOCATION OF ALL EQUIPMENT, WIRING DEVICES, ETC.
  - THE ELECTRICAL CONTRACTOR SHALL NOTIFY AND COOPERATE WITH THE MECHANICAL CONTRACTOR SUCH THAT NO PIPING, OR EQUIPMENT FOREIGN TO THE OPERATION OF THE ELECTRICAL EQUIPMENT SHALL BE PERMITTED TO BE INSTALLED IN, ENTER OR PASS THROUGH ELECTRICAL ROOMS OR SPACES; OR ABOVE OR BELOW ELECTRICAL EQUIPMENT IN THE OTHER AREAS.
  - ALL PENETRATIONS OF FLOORS, WALLS AND CEILINGS SHALL BE SEALED WITH APPROVED MATERIAL.
  - FOR PACKAGE EQUIPMENT PROVIDED ON THE PROJECT, SOME CONDUITS AND WIRES ARE SHOWN ON THE DRAWINGS, BUT IT IS EXPECTED THAT SOME ADDITIONAL CONDUITS AND WIRES MAY BE REQUIRED BY EQUIPMENT MANUFACTURERS TO COMPLETE INSTALLATION. IT IS INCUMBENT UPON THE GENERAL CONTRACTOR TO COORDINATE THIS REQUIREMENT WITH HIS SUBCONTRACTORS TO MAKE SURE THAT EQUIPMENT SUPPLIER PROVIDED ALL NECESSARY ELECTRICAL INFORMATION TO ELECTRICAL SUBCONTRACTOR FOR INCLUSION WHETHER SHOWN OR NOT SHOWN ON THE DRAWINGS.
  - IF OTHER THAN FIRST NAMED EQUIPMENT IS USED, IT SHALL BE CAREFULLY CHECKED FOR ELECTRICAL REQUIREMENTS AND CONTROL REQUIREMENTS OF ALTERNATE EQUIPMENT. SHOULD CHANGES OR ADDITIONS OCCUR IN ELECTRICAL WORK, OR THE WORK OF OTHER CONTRACTORS BE REVISED BY THE ALTERNATE EQUIPMENT, THE COST OF ALL CHANGES SHALL BE BORNE BY THE ELECTRICAL CONTRACTOR.

Sheet Number	Sheet Title
E-1.1	LEGEND
E-1.2	TABLES
E-2.1	DETAILS, SHT. 1
E-2.2	DETAILS, SHT. 2
E-2.3	DETAILS, SHT. 3
<del>E-3.1</del>	<del>11400 S STATE STREET DIAGRAMS, SHT. 1</del>
<del>E-3.2</del>	<del>11400 S STATE STREET DIAGRAMS, SHT. 2</del>
<del>E-3.3</del>	<del>11400 S STATE STREET SITE PLAN</del>
<del>E-3.4</del>	<del>11400 S STATE STREET VAULT PLAN</del>
E-4.1	11400 S 200 E DIAGRAMS
E-4.2	11400 S 200 E VAULT PLAN
E-5.1	11400 S 700 E DIAGRAMS
E-5.2	11400 S 700 E SITE PLAN
E-5.3	11400 S 700 E VAULT PLAN

FILE NAME:  
FILE DATE:



DESIGNED	KBH	3
DRAFTED	GDS	2
CHECKED	KBH	1
DATE	JUNE 2022	NO.

NO.	DATE	REVISIONS	BY	APVD.

SCALE  
NONE





**CONDUIT/CONDUCTOR SCHEDULE  
THHN, THWN, THWN-2**

AMP RATING	DRAWING ID TAG.	CONDUCTOR QTY.*	CONDUCTOR SIZE	MIN. CONDUIT SIZE	CONDUIT SIZE EXCEPTIONS	
20**	212	2	#12	3/4"		
20+	312	3		3/4"		
	412	4		3/4"		
30**	20	2	#10	3/4"		
30+	30	3		3/4"		
	40	4		3/4"		
40**	28	2	#8	3/4"		
50+	38	3		3/4"		
	48	4		3/4"		
55**	26	2	#6	3/4"		
65+	36	3		3/4"		
	46	4		3/4"	1"(C9)	
70**	24	2	#4	3/4"	1"(C2,C9)	
85+	34	3		1"	3/4"(C4),1-1/4"(C9)	
	44	4		1"	1-1/4"(C9)	
95**	22	2	#2	1"		
115+	32	3		1"	1-1/4"(C9)	
	42	4		1-1/4"		
110**	21	2	#1	1-1/4"	1"(C3,C4)	
130+	31	3		1-1/4"	1"(C3)	
	41	4		1-1/4"	1-1/2"(C2,C9,C10)	
150	210	2	1/0	1-1/4"		
	310	3		1-1/4"	1-1/2"(C3,C9)	
	410	4		1-1/2"	2"(C9)	
175	220	2	2/0	1-1/4"	1-1/2"(C3,C4,C9)	
	320	3		1-1/2"		
	420	4		2"		
200	230	2	3/0	1-1/2"	1-1/4"(C4)	
	330	3		1-1/2"	2"(C3,C9)	
	430	4		2"		
230	240	2	4/0	1-1/2"	2"(C3)	
	340	3		2"		
	440	4		2"	2-1/2"(C9)	
255	225	2	250	2"	1-1/2"(C4)	
	325	3		2"	2-1/2"(C1,C8)	
	425	4		KCMIL	2-1/2"	2"(C4)
310	235	2	350	2"	2-1/2"(C9)	
	335	3		KCMIL	2-1/2"	2"(C4)
	435	4		KCMIL	3"	2-1/2"(C1,C4)
380	250	2	500	2-1/2"	2"(C4)	
	350	3		KCMIL	3"	2-1/2"(C1,C4)
	450	4		KCMIL	3"	3-1/2"(C9)
475	275	2	750	3"		
	375	3		KCMIL	3-1/2"	3"(C1,C7,C8)
	475	4		KCMIL	4"	3-1/2"(C1,C4,C8)

\* CONDUCTOR QUANTITY DOES NOT INCLUDE GROUNDING CONDUCTORS. SEE EQUIPMENT GROUNDING CONDUCTORS FOR WIRE SIZES.

WHERE: C1 = ELECTRICAL METALLIC TUBING    "\*\*\*" = 60°C RATING  
 C2 = ELECTRICAL NON-METALLIC TUBING    "+" = 75°C RATING  
 C3 = FLEXIBLE STEEL CONDUIT  
 C4 = INTERMEDIATE METALLIC CONDUIT  
 C7 = LIQUIDTIGHT FLEXIBLE METAL CONDUIT  
 C8 = RIGID METALLIC CONDUIT  
 C9 = PVC SCHEDULE 80 CONDUIT  
 C10 = PVC SCHEDULE 40 CONDUIT  
 "\*\*\*" = RATED AMPACITY AT 60°C  
 "+" = RATED AMPACITY AT 75°C  
 USE 60°C CONDUCTOR RATING WHEN TERMINATION RATINGS ARE NOT PUBLISHED

**GROUNDING ELECTRODE  
CONDUCTOR SERVICE  
ENTRANCE OR SEPARATELY  
DERIVED SYSTEM**

COPPER CONDUCTOR	WIRE SIZE
#2 OR SMALLER	#8
1 OR 1/0	#6
2/0 OR 3/0	#4
>3/0 THRU 350 KCMIL	#2
>350 KCMIL THRU 600 KCMIL	1/0

**FIXTURE SCHEDULE**

TYPE	DESCRIPTION	MANUFACTURER		FX VA	LAMP	LUMENS	KELVIN	MOUNTING	NOTES
		NAME	CATALOG NO.						
F1	4' LED ENCLOSED INDUSTRIAL, FIBERGLASS HOUSING, DAMP LOCATION, MVOLT	METALUX	4VT2-LD5-4-DR-UNV-L840-CD1-WL-U	38	LED	4000	4000	SURFACE	
F2	2' LED ENCLOSED INDUSTRIAL, FIBERGLASS HOUSING, WET LOCATION, UNIVERSAL VOLTAGE	METALUX	2VT2-LD5-3-DR-UNV-L840-WL-SSL	22	LED	3000	4000	SURFACE	

H.P.E. INC. ELECTRICAL ENGINEERS  
 POWER SYSTEMS, CONTROL & INSTRUMENTATION SYSTEMS  
 HEGERHORST POWER ENGINEERING INCORPORATED (801) 642-2051  
 708 EAST 50 SOUTH AMERICAN FORK, UT 84003 FAX (801) 642-2154  
 HPE PROJECT: 23.066 ©2021  
 FOR INFORMATION ABOUT THIS JOB, PLEASE CONTACT: KEITH HEGERHORST

**GENERAL NOTES:**

1. NOT USED.

**SHEET KEYNOTES:**

1. NOT USED.

**EQUIPMENT GROUNDING  
CONDUCTORS**

FUSE OR CB SIZE	SIZE (COPPER)
15	14
20	12
30	10
40	10
60	10
100	8
200	6
300	4
400	3
500	2
600	1
800	1/0
1000	2/0
1200	3/0
1600	4/0
2000	250
2500	350

FILE NAME:  
FILE DATE:





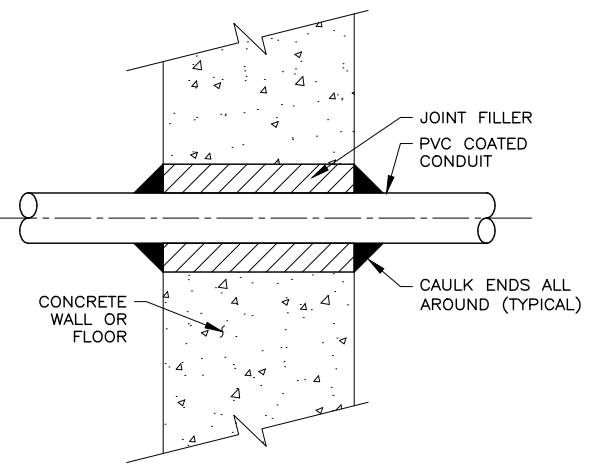

**CONDUIT PENETRATION THROUGH EXISTING CONCRETE**

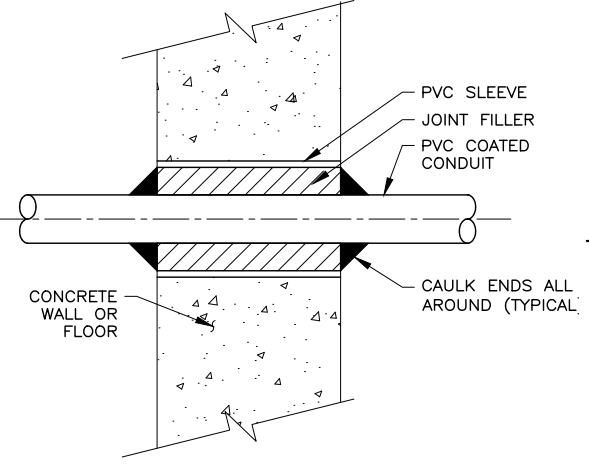

**CONDUIT PENETRATION THROUGH NEW CONCRETE**

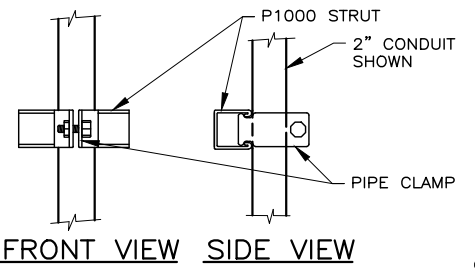

**CONDUIT PIPE CLAMPS\***

SIZE	EMT	RGS	EMT/GRS
1/2"	P1426	P1111	-
3/4"	P1427	P1112	P1212
1"	P1428	P1113	P1213
1-1/4"	P1429	P1114	P1214
1-1/2"	P1430	P1115	P1215
2"	P1431	P1117	P1217
2-1/2"	P1118	P1118	-
3"	P1119	P1119	-
3-1/2"	P1120	P1120	-
4"	P1121	P1121	-

\* = SUPPLIED WITH SLOTTED HEAD SCREW AND NUT

**TYPICAL CONDUIT SUPPORT CLAMP**

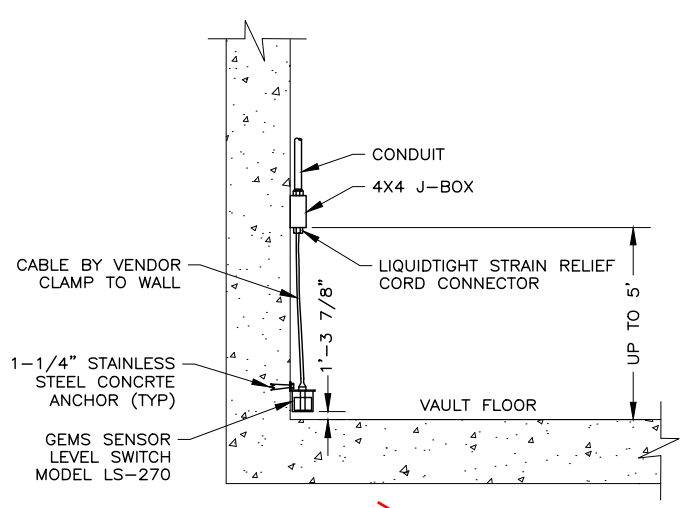

**FLOOR FLOOD SWITCH**  
 SCALE: 1"=1'-0"  
 1  
~~E-3.4~~ E-4.2  
 1  
 E-5.3

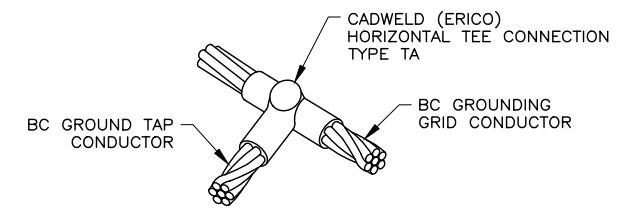

**WELDED GROUND CONNECTION**

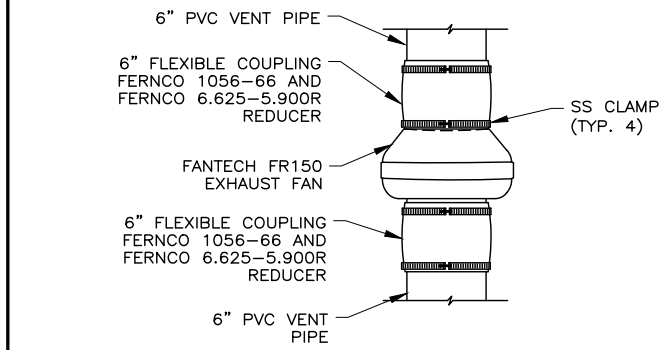

**VAULT EXHAUST FAN**  
 SCALE: 1-1/2"=1'-0"  
~~2~~ 2  
~~E-3.4~~ E-4.2  
 2  
 E-5.3

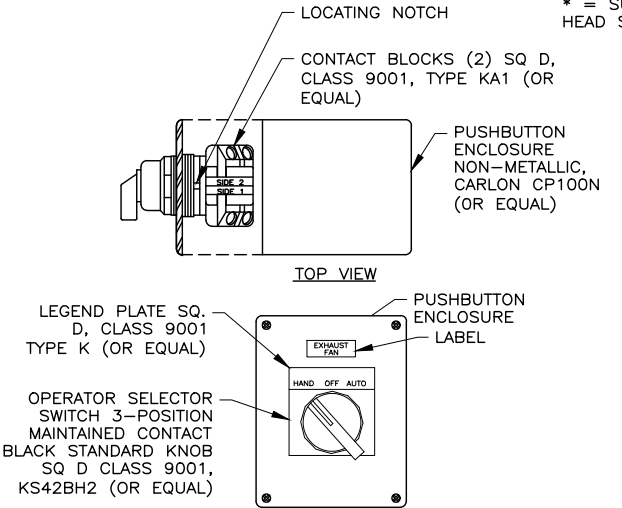

**HOA SWITCH**  
 SCALE: 1"=1'-0"  
~~3~~ 3  
~~E-3.4~~ E-4.2  
 3  
 E-5.3

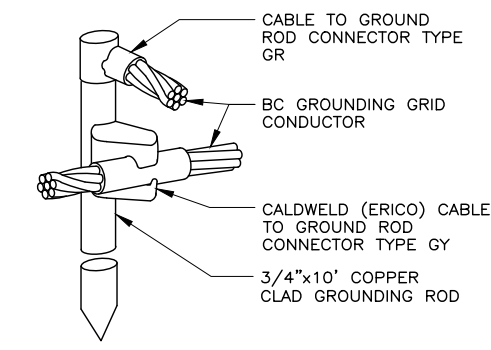

**GROUND ROD CONNECTION**  
 SCALE: NONE  
 4  
 E4.2

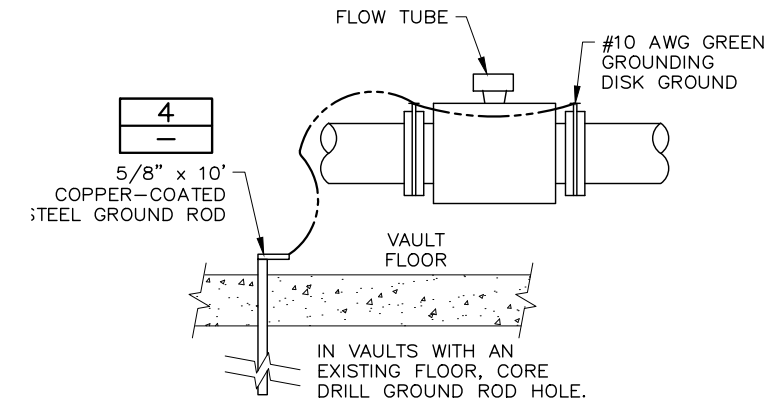

**FLOW METER GROUNDING**  
 SCALE: 3/4"=1'-0"  
 4  
 5  
~~E-5.3~~ E-3,4

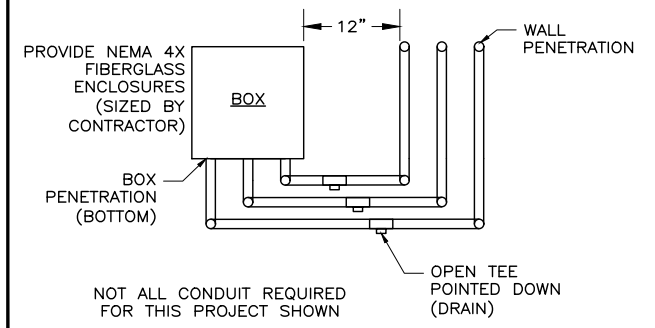

**VAULT CONDUIT PENETRATION**  
 SCALE: 1"=1'-0"  
 6  
 E-4.2

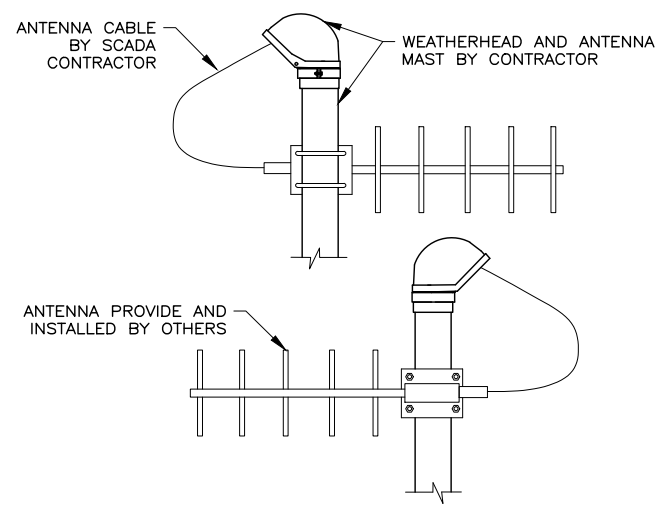

**ANTENNA MAST WEATHERHEAD**  
 SCALE: NONE  
 1  
 E-2.2

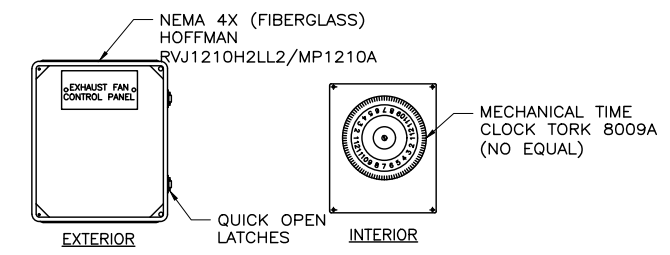

**EXHAUST FAN TIME SWITCH ENCLOSURE**  
 SCALE: NONE  
~~8~~ 8  
~~E-3.4~~ E-4.2  
 8  
 E-5.3



DESIGNED	KBH	3			
DRAFTED	GDS	2			
CHECKED	KBH	1			
DATE	JUNE 2022	NO.		DATE	

SCALE: AS SHOWN

**GENERAL NOTES:**

1. NOT USED.

**SHEET KEYNOTES:**

1. NOT USED.

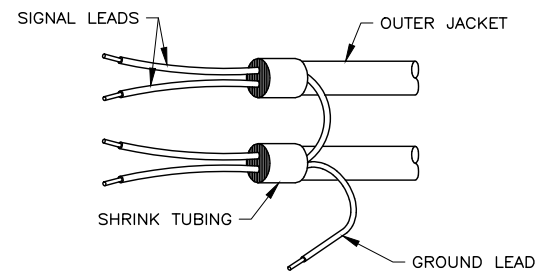

UNACCEPTABLE METHOD OF GROUNDING CONTROL CABLE SHIELD NTS

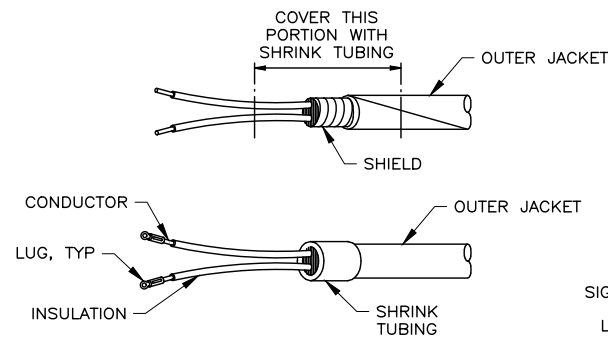

NOTE:  
SHIELD NOT GROUNDED AT TERMINATION.

TERMINATION OF SHIELDED CONTROL CABLE NTS

SIGNAL WIRE TERMINATIONS

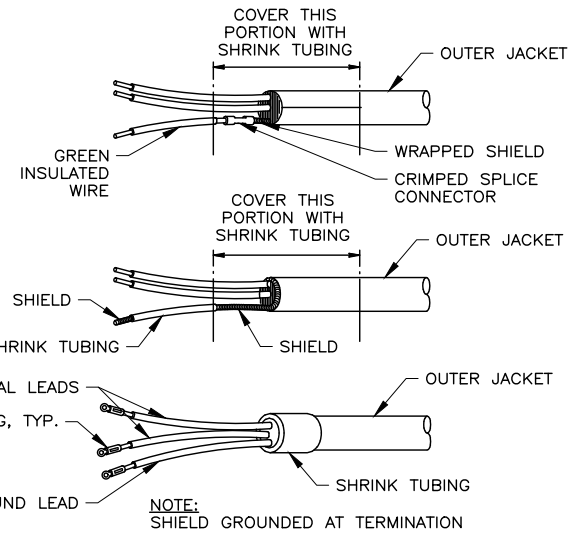

NOTE:  
SHIELD GROUNDED AT TERMINATION

TERMINATION OF SHIELDED CONTROL CABLE

FILE NAME:  
FILE DATE:

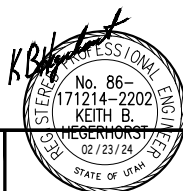

DESIGNED	KBH	3			
DRAFTED	GDS	2			
CHECKED	KBH	1			
PROJECT ENGINEER	DATE	JUNE 2022	NO.	DATE	

REVISIONS		BY	APVD.

SCALE  
AS SHOWN



2023 VAULT IMPROVEMENT PROJECT  
ELECTRICAL  
DETAILS, SHT. 3

SHEET  
E-2.3  
127.40.100



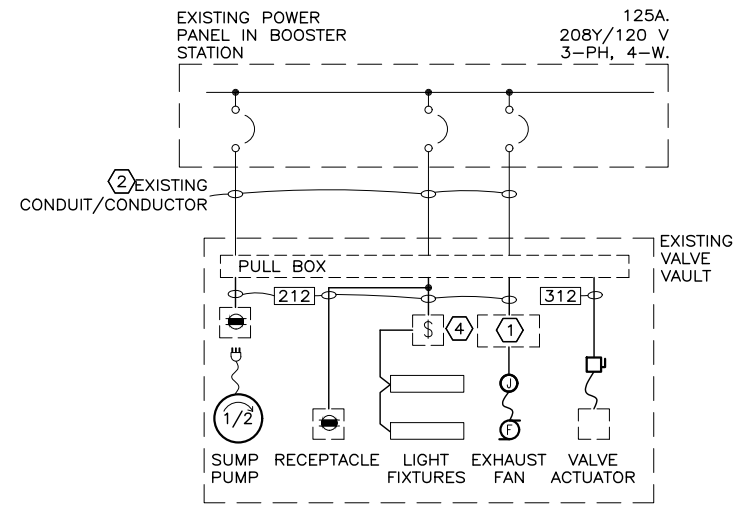

POWER ONE-LINE DIAGRAM

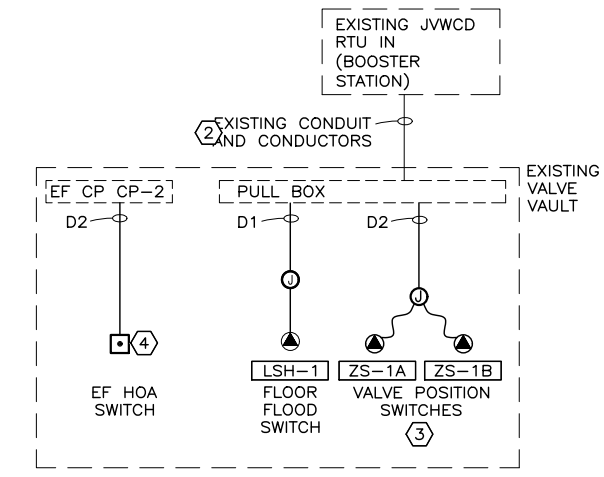

INSTRUMENTATION AND CONTROL ONE-LINE DIAGRAM

I&C WIRE/CONDUIT TABLE

IDENT.	CONDUIT SIZE	CONDUCTOR		SIGNAL DESCRIPTION
		QTY	SIZE	
A1	3/4"	1	#18TSP	1 ANALOG SIGNAL
A2	3/4"	2	#18TSP	2 ANALOG SIGNALS
A3	3/4"	3	#18TSP	3 ANALOG SIGNALS
IDENT.	CONDUIT SIZE	CONDUCTOR		SIGNAL DESCRIPTION
		QTY	SIZE	
D1	3/4"	2	#14	1 DISCRETE SIG.
D2	3/4"	3	#14	2 DISCRETE SIG.
D3	3/4"	4	#14	3 DISCRETE SIG.
D4	3/4"	5	#14	4 DISCRETE SIG.

**GENERAL NOTES:**

1. REFER TO E-4.2 FOR VAULT ELECTRICAL PLAN.

**SHEET KEYNOTES:**

1. EXHAUST FAN TIMER ENCLOSURE.
2. QUANTITY AND SIZES OF CONDUIT(S) FROM VAULT TO BOOSTER STATION POWER AND JWCD RTU HAVE NOT BEEN FIELD VERIFIED. IT IS ANTICIPATED THAT THE EXISTING CONDUIT AND CONDUCTORS ARE IN GOOD CONDITION AND WILL REMAIN AS-IS. COORDINATE WITH JWCD DURING CONSTRUCTION FOR CB ASSIGNMENT AND ACCESS TO THE BOOSTER PUMP STATION DURING CONSTRUCTION.
3. VALVE NORMALLY REMAINS FULL-OPEN. VALVE POSITION WILL BE MANUALLY OPERATED AT THE ACTUATOR INSIDE THE VAULT. WIRE VALVE POSITION LIMIT SWITCHES TO JWCD RTU AS SHOWN. COORDINATE TO PROVIDE JWCD WITH THE CONDUCTOR TERMINATION INFORMATION DURING CONSTRUCTION.
4. DEVICE INSTALLED AT VAULT ENTRY.

FILE NAME:  
FILE DATE:



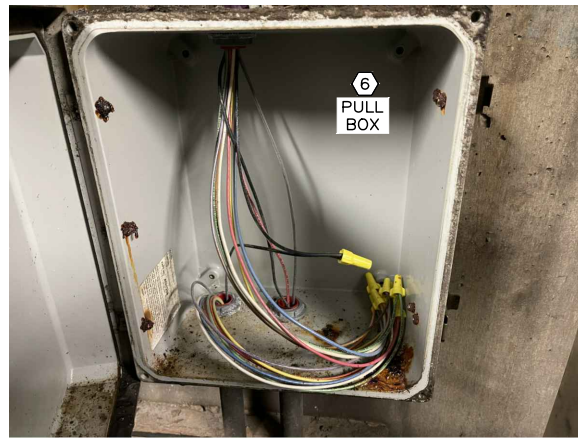
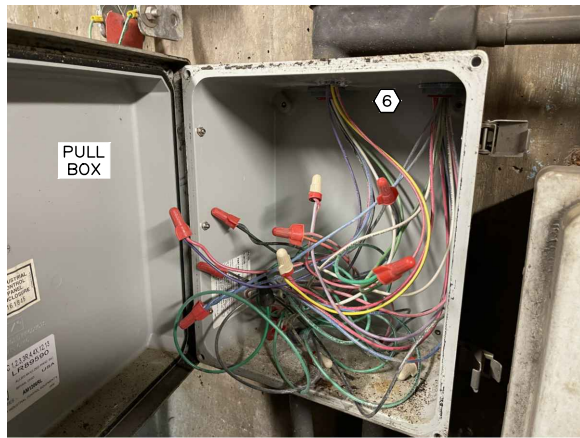
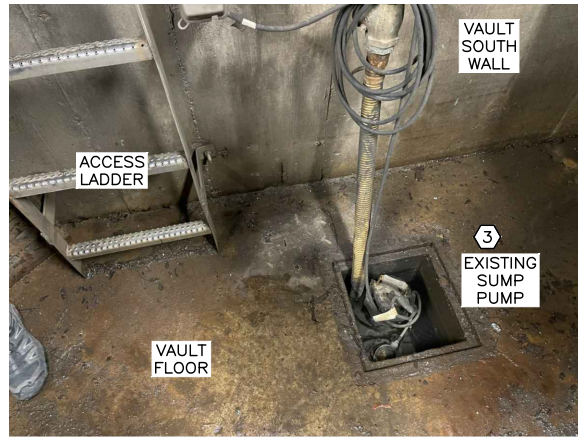
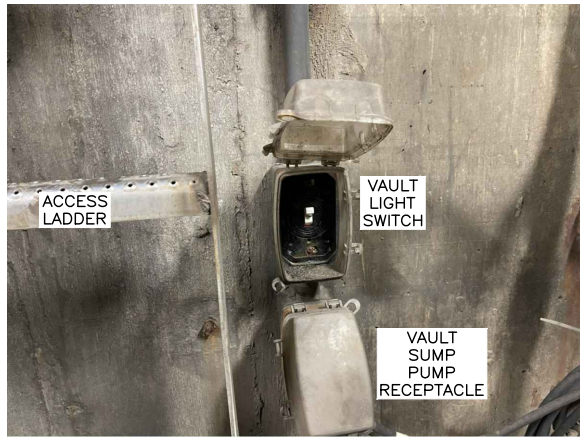
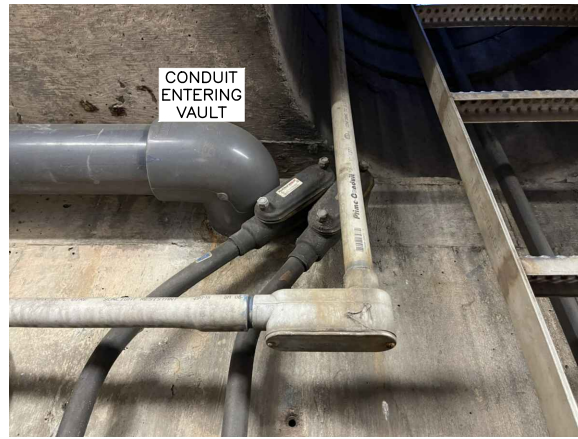
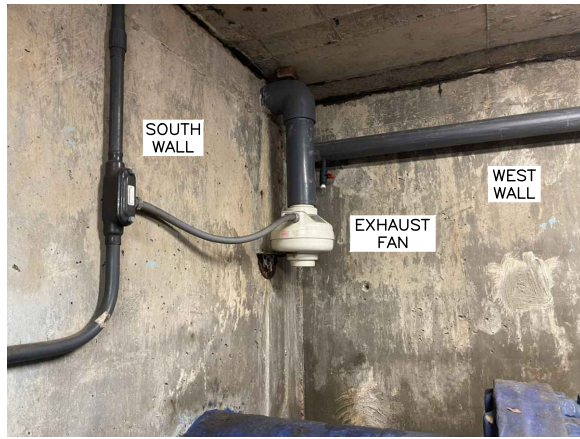

**ELECTRICAL POWER, I & C PLAN ITEMS (E4.2)**

DRAWING ID	TAG	DESCRIPTION	LOCATION
15	SP-1	SUMP PUMP	VAULT
16	EF-1	EXHAUST FAN	VAULT
21	LSH-1	FLOOR WATER LEVEL SWITCH	VAULT
23	F1	LIGHT FIXTURE	VAULT
24	REC-1	VAULT RECEPTACLE	VAULT
31	CP-2	EXHAUST FAN CONTROL PANEL	VAULT
33	HS-1	EXHAUST FAN HOA SWITCH	VAULT
40	ZS-1A	VALVE FULL-OPEN POSITION SWITCH	VAULT
41	ZS-1B	VALVE FULL-CLOSED POSITION SWITCH	VAULT
42	VA-1	VALVE ACTUATOR	VAULT

H.P.E. INC. ELECTRICAL ENGINEERS  
 POWER SYSTEMS, CONTROL & INSTRUMENTATION SYSTEMS  
 HEGERHORST POWER ENGINEERING INCORPORATED (801) 642-2051  
 708 EAST 50 SOUTH AMERICAN FORK, UT 84003 FAX (801) 642-2154  
 HPE PROJECT: 23.066 ©2021  
 FOR INFORMATION ABOUT THIS JOB, PLEASE CONTACT: KEITH HEGERHORST

**GENERAL NOTES:**

- ALL NEW 120 VAC POWER WIRING INSIDE THE VAULT SHALL BE 3/4"C WITH #12 CONDUCTORS. ALL DISCRETE SIGNAL WIRING INSIDE THE VAULT SHALL BE 3/4"C, WITH #14 CONDUCTORS.
- NEW CONDUIT TO BE WALL MOUNTED. DO NOT INSTALL NEW CONDUIT ON VAULT CEILING.
- THE EXISTING 3-PHASE VALVE ACTUATOR IS POWERED FROM A 20A/3P CB IN THE EXISTING PANEL IN THE BOOSTER PUMP STATION. CONTRACTOR SHALL RE-USE THE EXISTING BURIED CONDUCTORS AND CONDUIT. MAINTAIN CIRCUIT INTEGRITY. PROVIDE NEW GRS CONDUIT INSIDE THE VAULT AS REQUIRED.
- THE LIGHTS AND SUMP PUMP ARE POWERED FROM A 20A/1P CB IN THE EXISTING PANEL IN THE BOOSTER PUMP STATION. CONTRACTOR SHALL RE-USE THE EXISTING BURIED CONDUCTORS AND CONDUIT TO THE POWER SOURCE. MAINTAIN CIRCUIT INTEGRITY.
- THE VENTILATION FAN IS POWERED FROM A 20A/1P CB IN THE EXISTING PANEL IN THE BOOSTER PUMP STATION. CONTRACTOR SHALL RE-USE THE EXISTING BURIED CONDUCTORS AND CONDUIT TO THE POWER SOURCE. MAINTAIN CIRCUIT INTEGRITY. PROVIDE AND INSTALL A NEW TIME SWITCH ENCLOSURE AS SHOWN.
- INSTALL ALL NEW DEVICES (RECEPTACLES AND SWITCHES) IN NEW ELECTRICAL BOXES IN THE VAULT.

**SHEET KEYNOTES:**

- HOA SWITCH AND LIGHT AT VAULT ENTRANCE. LOCATE SO AN OPERATOR CAN REACH THE SWITCHES WITHOUT ENTERING THE VAULT.
- LOCATE FLOOD SWITCH BELOW ENCLOSURES.
- NEW SUMP PUMP IS BEING INSTALLED IN A NEW SUMP. INSTALL RECEPTACLE (NOT SHOWN) FOR PUMP ON WALL NEAR ACCESS LADDER.
- INSTALL EF TIME SWITCH ENCLOSURE ABOVE EXISTING PIPE.
- THE EXISTING VAULT FIXTURES ARE INSTALLED ON THE VAULT ROOF, WHICH IS BEING REMOVED. PROVIDE NEW FIXTURES AND WIRE TO A NEW SWITCH AND THE EXISTING POWER SOURCE AS REQUIRED. FIXTURE SCHEDULE ON E-1.2. INSTALL THE NEW FIXTURES ON THE VAULT WALL. INSTALL FIXTURES 6-IN BELOW CEILING.
- REMOVE AND REPLACE ALL PULL BOXES. REPLACE WITH FIBERGLASS ENCLOSURES (SIZED BY CONTRACTOR).

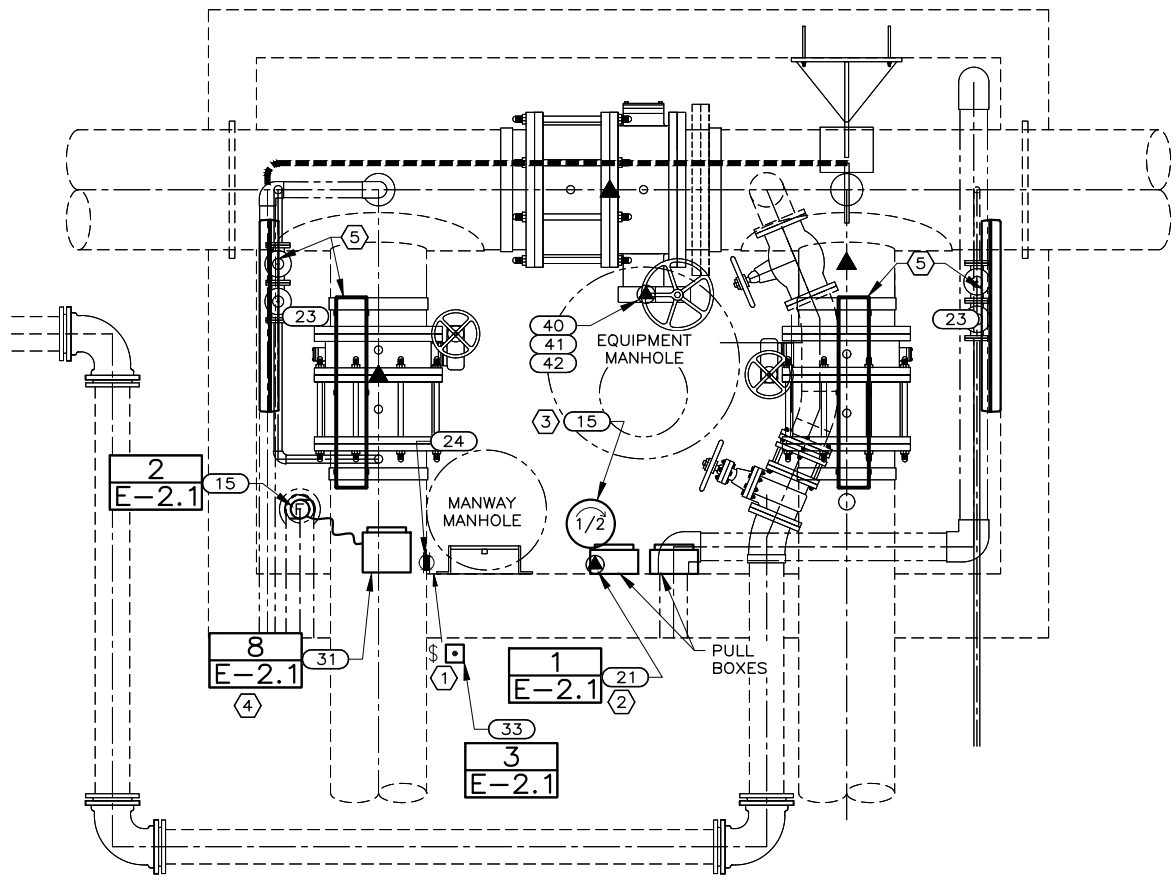

**VAULT ELECTRICAL PLAN**  
 0 2' 4' 6'  
 1/2"=1'-0"  
 N

FILE NAME:  
 FILE DATE:



DESIGNED	KBH	3
DRAFTED	GDS	2
CHECKED	KBH	1
DATE	JUNE 2022	NO.

NO.	DATE	REVISIONS	BY	APVD.

SCALE  
 AS SHOWN



2023 VAULT IMPROVEMENT PROJECT  
 ELECTRICAL  
 11400 S 200 E VAULT PLAN

SHEET  
 E-4.2  
 127.40.100



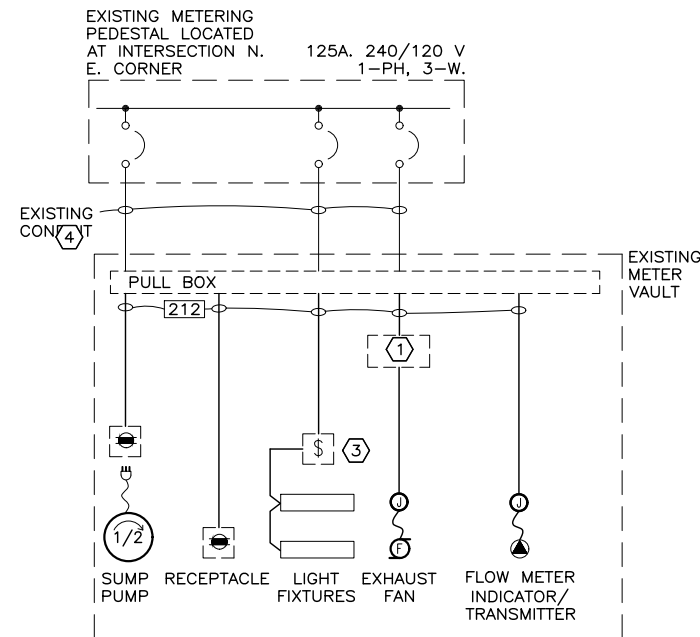

POWER ONE-LINE DIAGRAM

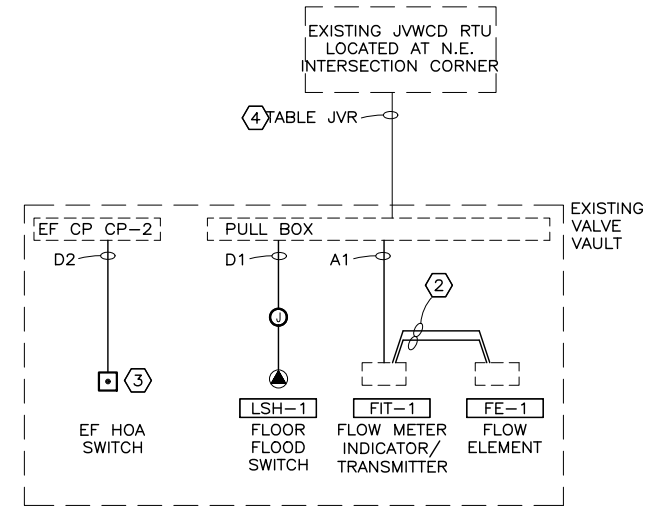

INSTRUMENTATION AND CONTROL ONE-LINE DIAGRAM

GENERAL NOTES:

1. REFER TO E-5.2 FOR VAULT SITE PLAN.
2. REFER TO E-5.3 FOR VAULT ELECTRICAL PLAN.

SHEET KEYNOTES:

1. EXHAUST FAN TIMER ENCLOSURE.
2. 1-1/2" C, CABLES SUPPLIED WITH FLOW METER.
3. ENTRY HATCH IS BEING RELOCATED. PROVIDE NEW LIGHT AND EF HOA SWITCH AT THE RELOCATED HATCH.
4. QUANTITY AND SIZES OF CONDUIT(S) FROM VAULT TO METERING PEDESTAL AND RTU HAS NOT BEEN FIELD VERIFIED. CONDITION HAS NOT BEEN FIELD VERIFIED. IT IS ANTICIPATED THAT THE EXISTING CONDUIT CAN BE RE-USED AS-IS. FOR POWER CIRCUITS, INSTALL #12 WIRE AS REQUIRED.

I&C WIRE/CONDUIT TABLE

IDENT.	CONDUIT SIZE	CONDUCTOR		SIGNAL DESCRIPTION
		QTY	SIZE	
A1	3/4"	1	#18TSP	1 ANALOG SIGNAL
A2	3/4"	2	#18TSP	2 ANALOG SIGNALS
A3	3/4"	3	#18TSP	3 ANALOG SIGNALS
IDENT.	CONDUIT SIZE	CONDUCTOR QTY	CONDUCTOR SIZE	SIGNAL DESCRIPTION
D1	3/4"	2	#14	1 DISCRETE SIG.
D2	3/4"	3	#14	2 DISCRETE SIG.
D3	3/4"	4	#14	3 DISCRETE SIG.
D4	3/4"	5	#14	4 DISCRETE SIG.

TABLE JVR (JVVCD RTU TO 700E VLT)

CONDUIT SIZE	CONDUCTOR		SIGNAL DESCRIPTION
	QTY	SIZE	
EXIST.	2	#14	VAULT FLOOD SWITCH (LSH-1)
	1	#18TSP	TURNOUT FLOW (FIT-1)
	2	#14	SPARE
	1	#18TSP	SPARE

FILE NAME:  
FILE DATE:



DESIGNED	KBH	3	
DRAFTED	GDS	2	
CHECKED	KBH	1	
PROJECT ENGINEER	DATE	JUNE 2022	NO. DATE

REVISIONS				BY	APVD.

SCALE  
NONE



2023 VAULT IMPROVEMENT PROJECT  
ELECTRICAL  
11400 S 700 E DIAGRAMS

SHEET  
E-5.1  
127.40.100

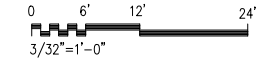
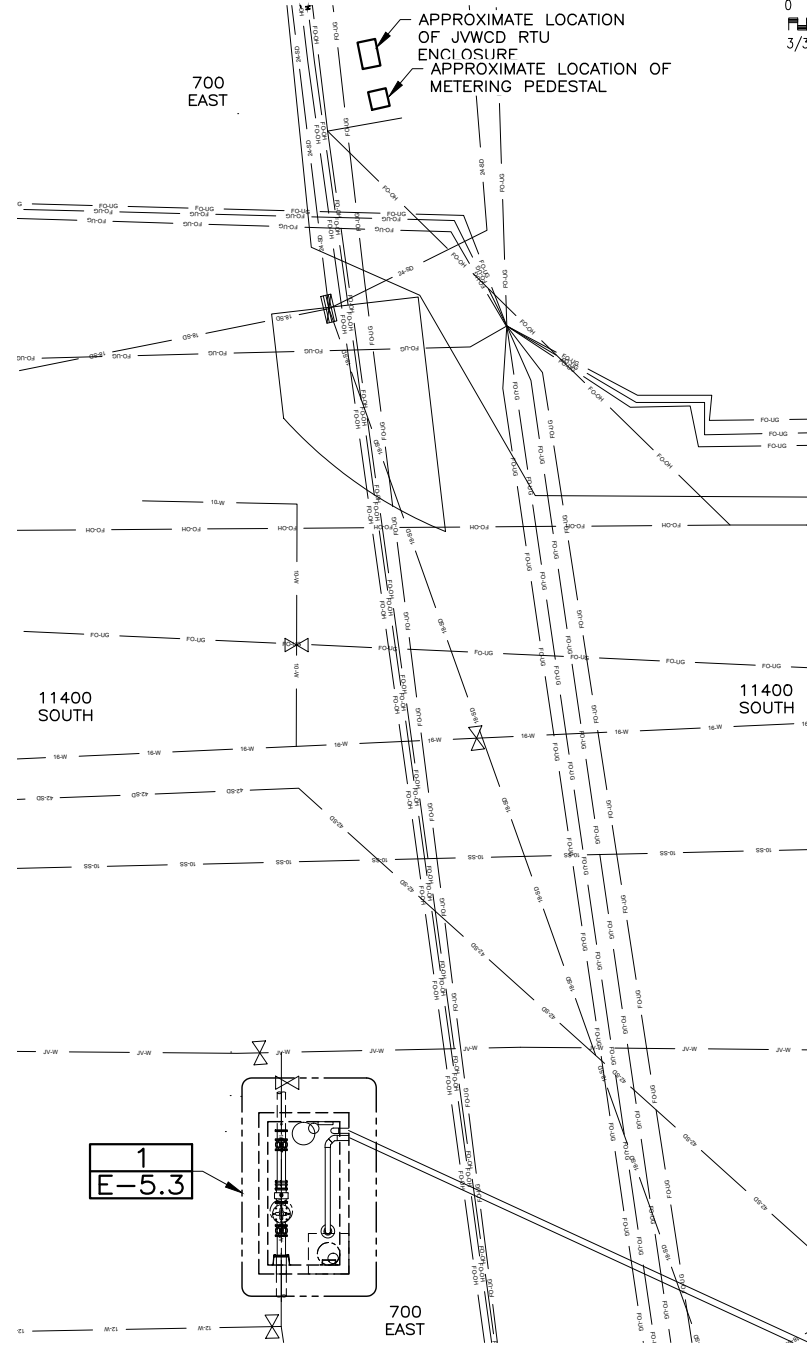
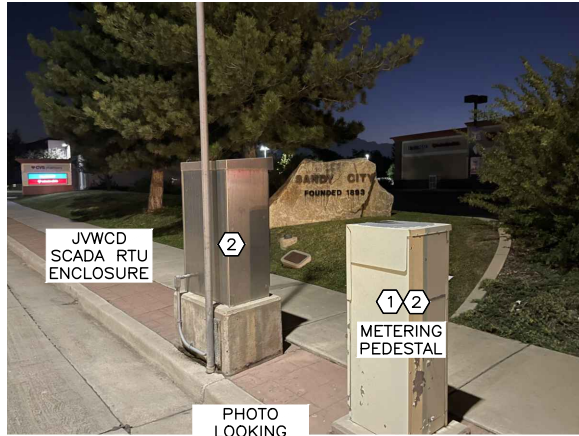

H.P.E. INC. ELECTRICAL ENGINEERS  
 POWER SYSTEMS, CONTROL & INSTRUMENTATION SYSTEMS  
 HEGERHORST POWER ENGINEERING INCORPORATED (801) 642-2051  
 708 EAST 50 SOUTH FAX (801) 642-2154  
 AMERICAN FORK, UT 84003  
 HPE PROJECT: 23.066 ©2021  
 FOR INFORMATION ABOUT THIS JOB, PLEASE CONTACT: KEITH HEGERHORST

- GENERAL NOTES:**
1. FOR WIRE AND CONDUIT REQUIREMENTS REFER TO ONE-LINE DIAGRAMS ON E-5.1 AND THE CONDUCTOR/CONDUIT TABLE ON E-1.2.
  2. REFER TO CIVIL DRAWINGS ADDITIONAL SITE INFORMATION.

- SHEET KEYNOTES:**
1. 120 V POWER SOURCE FOR VAULT AND RTU.
  2. METERING PEDESTAL AND JWCD RTU TO REMAIN AS-IS. EXCEPT THE INSTALLATION OF NEW CONDUCTORS IN THE EXISTING VAULT CONDUITS NO CONTRACTOR WORK ANTICIPATED, EXACT ROUTING OF CONDUIT IS UNKNOWN AND UNVERIFIED.

**SITE PLAN**

FILE NAME:  
FILE DATE:



DESIGNED	KBH	3			
DRAFTED	GDS	2			
CHECKED	KBH	1			
DATE	JUNE 2022	NO.	DATE		

REVISIONS		BY	APVD.

SCALE  
AS SHOWN



2023 VAULT IMPROVEMENT PROJECT  
ELECTRICAL  
11400 S 700 E SITE PLAN

SHEET  
E-5.2  
127.40.100



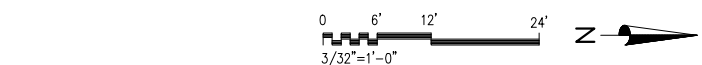
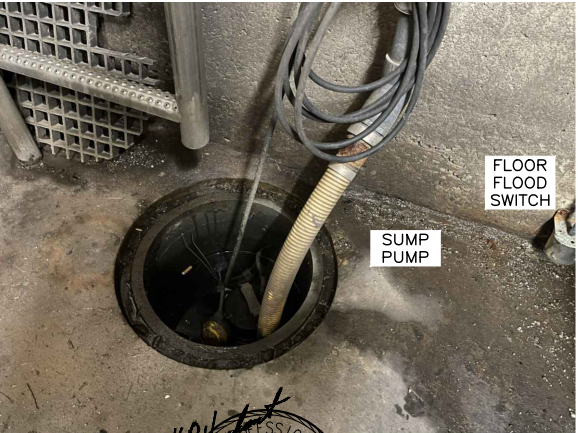
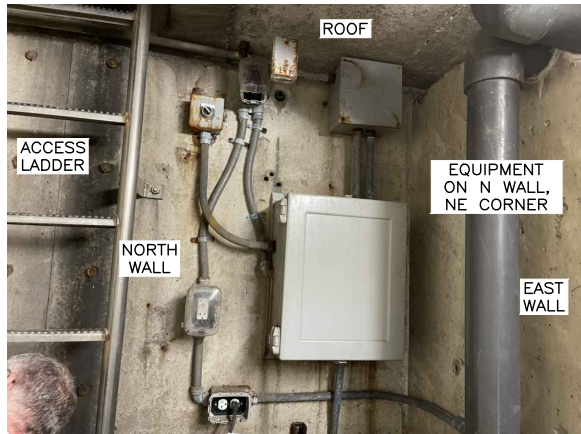
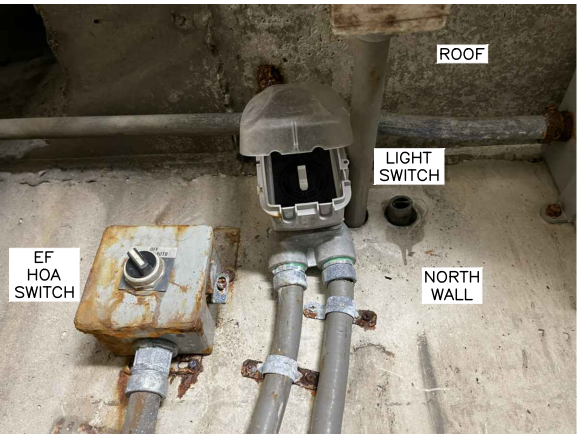
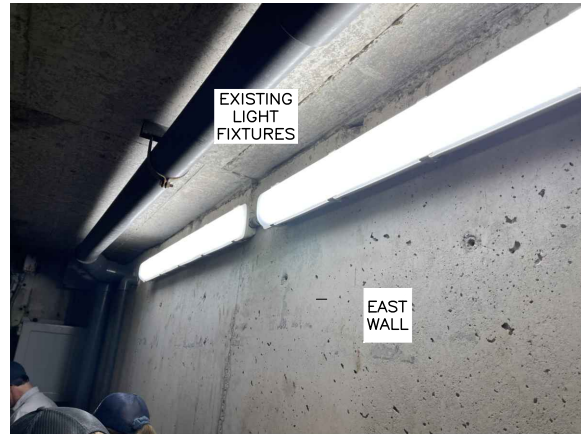
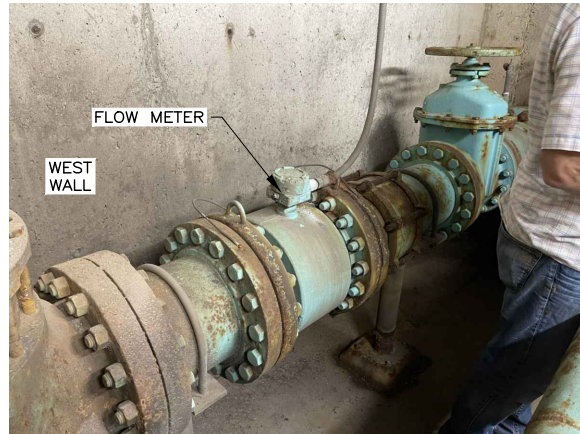

VAULT ELECTRICAL PLAN ITEMS (E-5.3)			
DRAWING ID	TAG	DESCRIPTION	LOCATION
15	SP-1	SUMP PUMP	VAULT
16	EF-1	EXHAUST FAN	VAULT
19	FE-1	FLOW ELEMENT	VAULT
21	LSH-1	FLOOR WATER LEVEL SWITCH	VAULT
23	F1	LIGHT FIXTURE	VAULT
24	REC-1	VAULT RECEPTACLE	VAULT
31	CP-2	EXHAUST FAN CONTROL PANEL	VAULT
33	HS-1	EXHAUST FAN HOA SWITCH	VAULT
38	FIT-1	FLOW INDICATOR/TRANSMITTER	VAULT

H.P.E. INC. ELECTRICAL ENGINEERS  
 POWER SYSTEMS, CONTROL & INSTRUMENTATION SYSTEMS  
 HEGERHORST POWER ENGINEERING INCORPORATED (801) 642-2051  
 708 EAST 50 SOUTH AMERICAN FORK, UT 84003 FAX (801) 642-2154  
 HPE PROJECT: 23.066 ©2021  
 FOR INFORMATION ABOUT THIS JOB, PLEASE CONTACT: KEITH HEGERHORST

- GENERAL NOTES:**
- ALL NEW 120 VAC POWER WIRING INSIDE THE VAULT SHALL BE 3/4"C WITH #12 CONDUCTORS. ALL DISCRETE SIGNAL WIRING INSIDE THE VAULT SHALL BE 3/4"C, WITH #14 CONDUCTORS.
  - THE 120 V SUPPLY IS LOCATED IN A METERING PEDESTAL ADJACENT TO THE JWCD RTU. CONTRACTOR SHALL RE-USE THE EXISTING BURIED CONDUIT AND INSTALL NEW CONDUCTORS. MAINTAIN CIRCUIT INTEGRITY.
  - IN THE VAULT, INSTALL ALL NEW GRC CONDUIT AND NEW DEVICES (RECEPTACLES AND SWITCHES) IN NEW ELECTRICAL BOXES.
  - ANALOG (FLOW METER) AND LEVEL SWITCH CIRCUIT MAY BE INSTALLED IN THE SAME CONDUIT TO THE RTU.

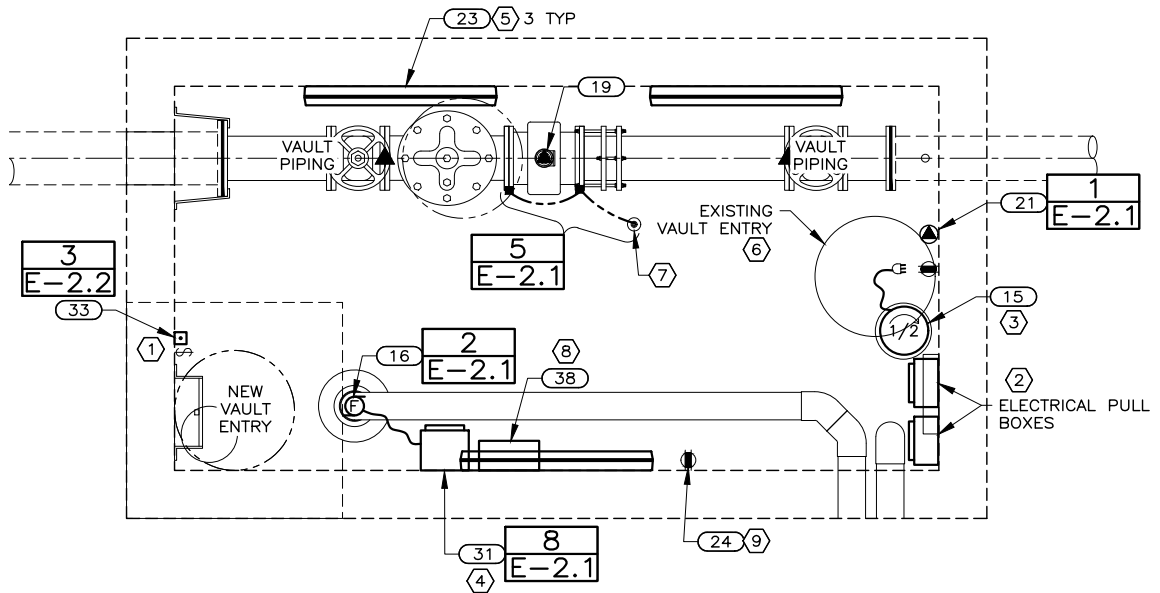

VAULT ELECTRICAL PLAN 1 E-5.2

- SHEET KEYNOTES:**
- INSTALL HOA SWITCH AND LIGHT AT VAULT ENTRANCE. LOCATE SO AN OPERATOR CAN REACH THE SWITCHES WITHOUT ENTERING THE VAULT.
  - REMOVE EXISTING PULL BOXES (PB). INSTALL TWO FIBERGLASS PULL BOXES (POWER & INSTRUMENTATION/CONTROL). PB SIZED BY CONTRACTOR AND LOCATED AS NEAR THE EXISTING CONDUIT WALL PENETRATIONS AS REASONABLE.
  - NEW SUMP PUMP IS INSTALLED IN THE EXISTING SUMP. WALL MOUNT NEW GFCI RECEPTACLE FOR PUMP (+36" AFF) AND PROVIDE IN-SERVICE COVER.
  - ENCLOSURE FOR EXHAUST FAN TIME SWITCH. SET TRIPPERS TO RUN THE FAN FOR 15 MINUTES TWICE DAILY.
  - THE EXISTING VAULT FIXTURES ARE TO BE REMOVED AND NEW FIXTURES INSTALLED. FIXTURE SCHEDULE ON E-1.2. INSTALL 6-IN BELOW VAULT CEILING. WIRE TO A NEW SWITCH AND THE EXISTING POWER SOURCE AS REQUIRED.
  - EXISTING VAULT MANHOLE TO BE ELIMINATED AND ACCESS LADDER REMOVED.
  - CORE DRILL FLOOR AND INSTALL A 5/8"x10' COPPER GROUND ROD FOR THE FLOW METER. CONNECT TO FLOW METER WITH #6 BC SOLID GROUND CONDUCTOR. GROUT HOLE AROUND GROUND ROD.
  - INSTALL TOP OF FLOW INDICATOR/TRANSMITTER AT +60" AFF.
  - INSTALL A GFCI DEVICE WITH A IN-SERVICE W/P COVER.

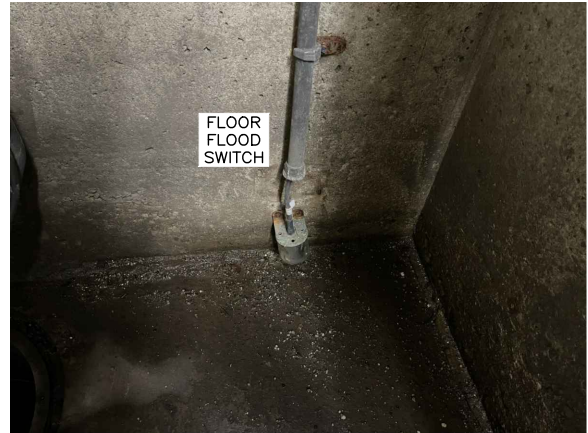

FILE NAME:  
 FILE DATE:  
 REGISTERED PROFESSIONAL ENGINEER  
 No. 86-171214-2202  
 KEITH B. HEGERHORST  
 STATE OF UTAH  
 PROJECT ENGINEER

DESIGNED	KBH	3					
DRAFTED	GDS	2					
CHECKED	KBH	1					
DATE	JUNE 2022	NO.	DATE	REVISIONS	BY	APVD.	

SCALE  
 AS SHOWN

2023 VAULT IMPROVEMENT PROJECT  
 ELECTRICAL  
 11400 S 700 E VAULT PLAN

SHEET  
 E-5.3  
 127.40.100



UDOT STANDARD REQUIREMENTS:

1. COMPLY WITH UDOT PERMIT.
2. COMPLY WITH SHEETS G-3, C-4, C-4A, C-5, & C-6.
3. COMPLY WITH UDOT STANDARD SPECS AND DRAWINGS.

2023 UDOT STANDARD SPECIFICATIONS

AVAILABLE ONLINE AT: <https://www.udot.utah.gov/connect/business/standards/>

- 01450 SUBMITTALS
- 01540 PUBLIC INFORMATION SERVICES
- 01554 TRAFFIC CONTROL
- 01558 TEMP PAVEMENT MARKINGS
- 01571 TEMP ENVIRONMENTAL CONTROLS
- 02701 PAVEMENT SMOOTHNESS
- 02705 CONC & ASPHALT CUTTING
- 02741 ASPHALT MIX
- 02745 ASPHALT MATERIAL
- 02748 PRIME COAT/TACK COAT
- 02752 PORTLAND CEMENT CONC PAVEMENT
- 02753 FULL DEPTH SLAB REPLACEMENT FOR CONC PAVEMENTS
- 02754 DOWEL BAR RETROFIT
- 02768 PAVEMENT MARKING MATERIALS
- 02787 BONDED WEARING MATERIALS
- 02981 GRINDING PAVEMENT
- 03055 PORTLAND CEMENT CONC
- 03058 RAPID STRENGTH CONC (RSC)
- 03152 CONC JOINT CONTROL
- 03211 REINF STEEL & WELDED WIRE
- 03310 STRUCTURAL CONCRETE
- 03390 CONC CURING
- 03575 FLOWABLE FILL
- 03934 STRUCTURAL POT HOLE PATCHING
- 05829 POURABLE JOINT SEAL
- 05830 ASPHALTIC PLUG JOINT
- 05831 COMPRESSION JOINT SEAL
- 05832 STRIP SEAL EXPANSION JOINT
- 05835 MODULAR EXPANSION JOINT

UDOT STANDARD REQUIREMENTS:

AVAILABLE ONLINE AT: <https://www.udot.utah.gov/connect/business/standards/>

SHEET NO.	TITLE
PV-1	JOINTS FOR HIGHWAYS WITH CONC TRAFFIC LANES AND SHOULDERS
PV-2	CONC PAVEMENT DETAILS 1 OF 2
PV-3	CONC PAVEMENT DETAILS 2 OF 2
PV-5	URBAN CONC PAVEMENT DETAILS
PV-9	DOWEL BAR RETROFIT
PV-10	UTILITY ORIENTATION/ADJUSTMENT OPTIONS IN PCCP

FILE NAME: PROJECTS\127 - JMWCD\42.100 - 2023-24 VAULTS IMPROVEMENT\CAD\PV-0 UDOT STANDARD SPECS & PLANS.DWG  
FILE DATE: 9/30/2024 13:04:34 (DD)

7/04

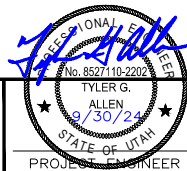

DESIGNED NPJ	3				
DRAFTED DD	2				
CHECKED TGA	1				
DATE SEPTEMBER 2024	NO.	DATE	REVISIONS	BY	APVD.

SCALE  
NONE



2024 VAULT IMPROVEMENT PROJECT  
UDOT STANDARD REQUIREMENTS  
STANDARD SPECS & PLANS

SHEET  
PV-0  
127.42.100



5-APR-2023 D:\N:\Standards\SpecSection\2024\_Standards (pub, Spring 2023)\Electronic Books\Master Drawings\Drawings\0101.dgn

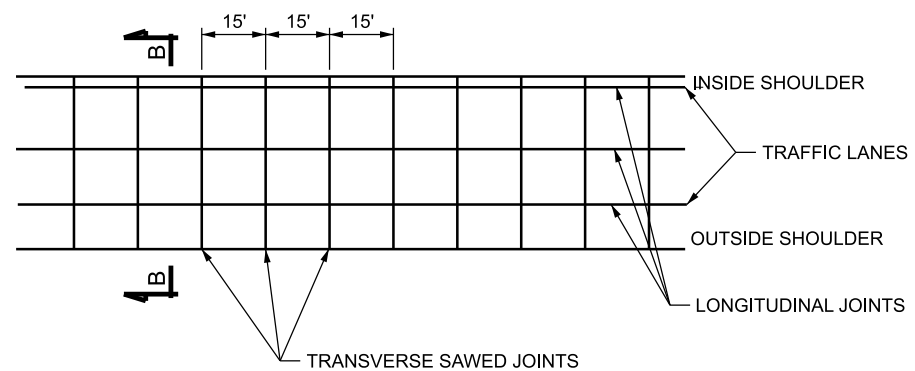

**TYPICAL JOINT LOCATION DETAIL**

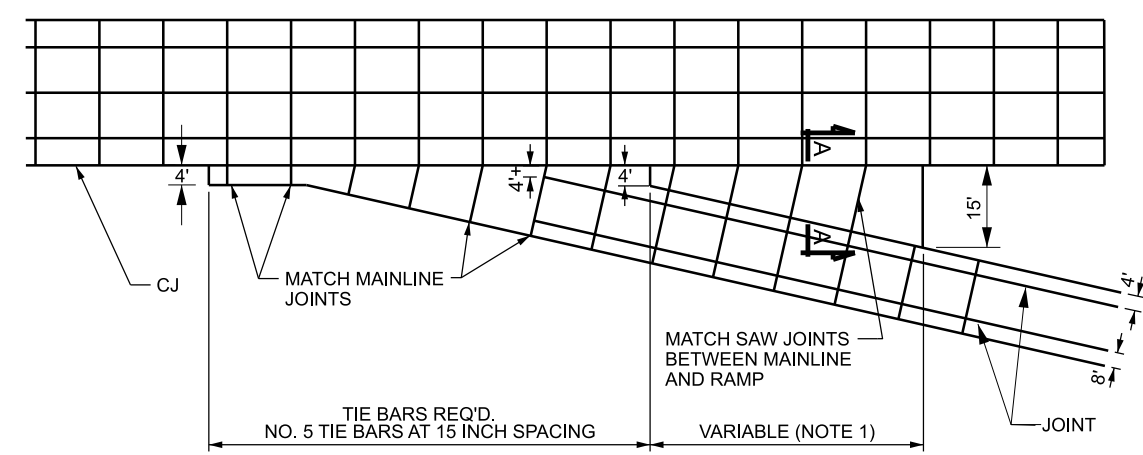

**SHOULDER TRANSITION FOR RAMP AND RAMP GORE PAVING DETAIL**

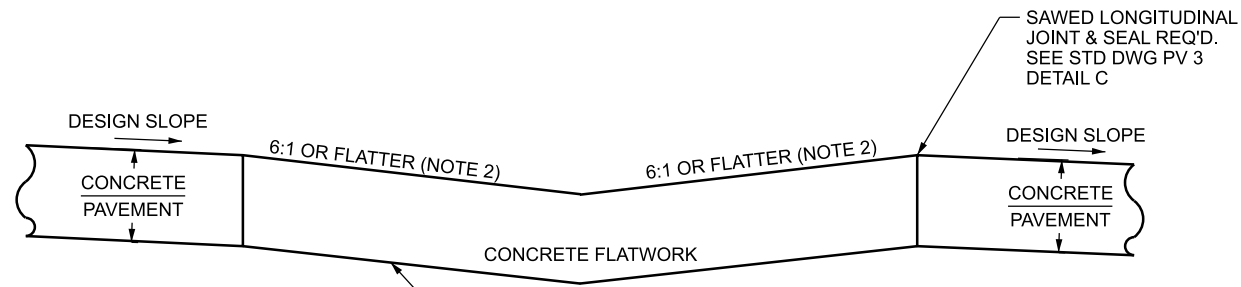

**SECTION A-A**

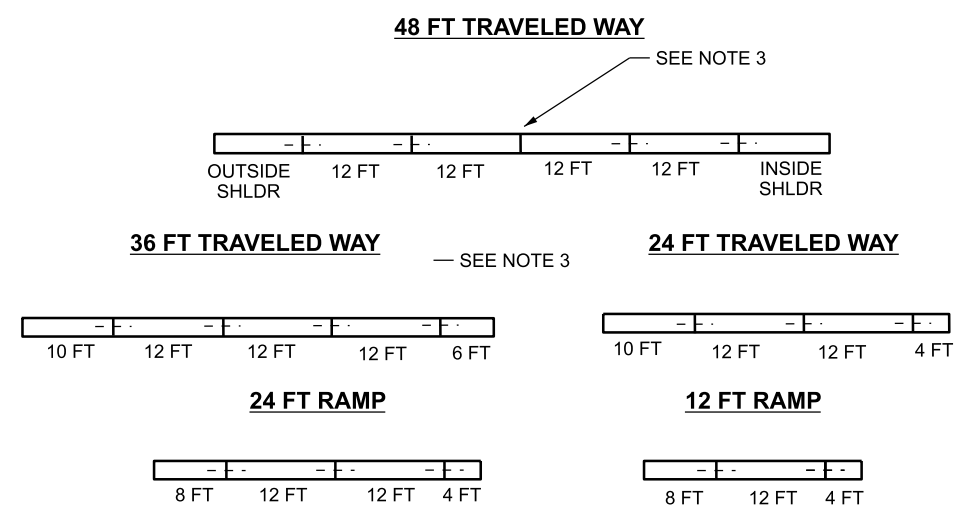

**SECTION B-B  
REQUIRED PAVING CONFIGURATIONS**

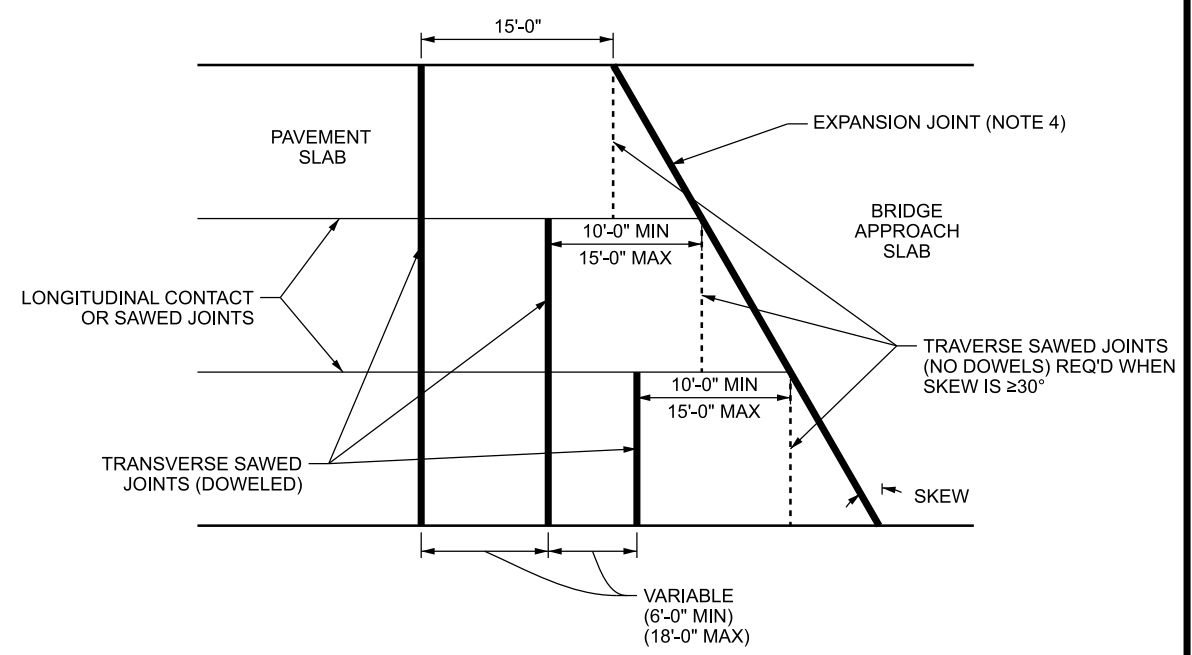

**SKEWED APPROACH SLAB**

**NOTES:**

1. ESTIMATED QUANTITIES FOR CONCRETE FLATWORK ARE CALCULATED ON TANGENT SECTION. IN ALL CASES LENGTH OF GORE PAVING WILL BE CARRIED AHEAD UNTIL THE DISTANCE BETWEEN PAVING IS 15 FT.
2. SLOPE MAY VARY TO MEET DESIGN CONDITIONS ON RAMP AND MAINLINE. GRADE TO DRAIN, ADJUST FOR FIELD CONDITIONS.
3. TIE ALL LONGITUDINAL JOINTS UNLESS ROADWAY INCLUDES MORE THAN THREE TRAVEL LANES. IN THAT CASE LEAVE ONE OF THE THREE CENTER LONGITUDINAL JOINTS UNTIED. DO NOT TIE MORE THAN FOUR LONGITUDINAL JOINTS TOGETHER FOR NEW CONSTRUCTION AND RECONSTRUCTION. CONTACT JOINT TIE BARS REQUIRED AT ALL LOCATIONS WHERE CONCRETE IS TO BE EXTENDED. SEE STD DWG PV 2 AND PV 3 FOR JOINT DETAILS.
4. SEE STRUCTURE PLANS FOR EXPANSION JOINT DETAILS.
5. ALL LONGITUDINAL JOINTS CAN BE CONTACT JOINTS OR SAWED JOINTS.

REVISIONS		NO.	DATE	APPR.	REMARKS
1	10-26-17	SA			ADDED THE SKEWED APPROACH SLAB DETAILS, CHANGES TO NOTES

**UTAH DEPARTMENT OF TRANSPORTATION**  
STANDARD DRAWINGS FOR ROAD AND BRIDGE CONSTRUCTION  
SALT LAKE CITY, UTAH  
STANDARD DRAWING EDITION

**2024 Standard Drawing**

**JOINTS FOR HIGHWAYS WITH CONCRETE TRAFFIC LANES AND SHOULDERS**

STANDARD DRAWING TITLE

STD. DWG. NO.  
**PV 1**

5-APR-2023 D:\N\Standards\SpecSection\2024\_Standards (pub, Spring 2023)\Electronic Books\Master Drawings\Drawings\P102.dgn

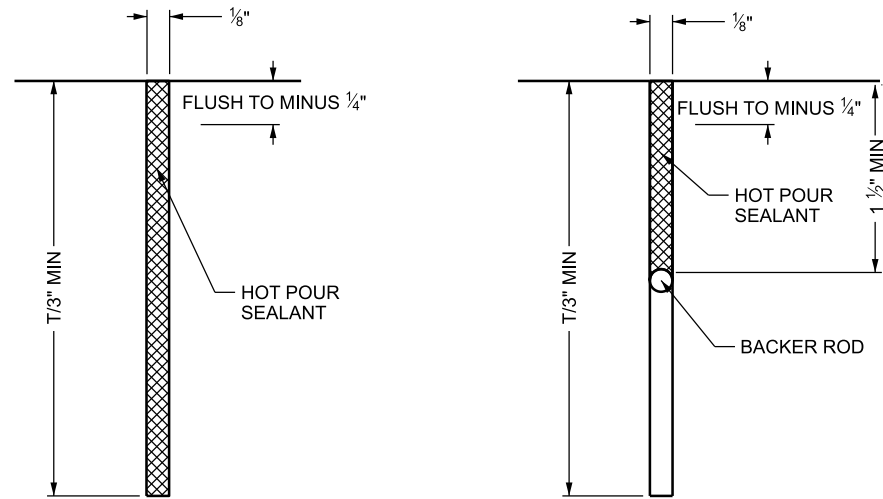

**DETAIL "A"**

**DETAIL "B"**  
OPTIONAL INSTALLATION

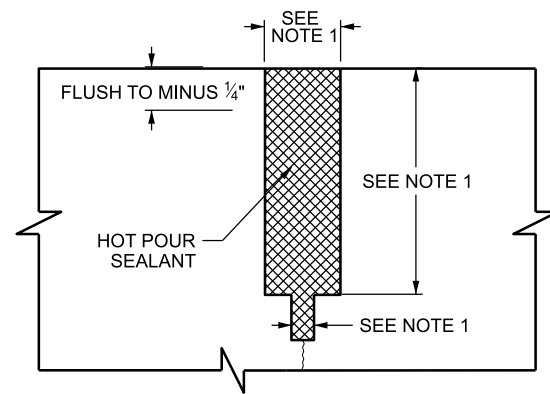

**DETAIL "D"**  
REHABILITATION OF EXISTING SILICONE JOINT

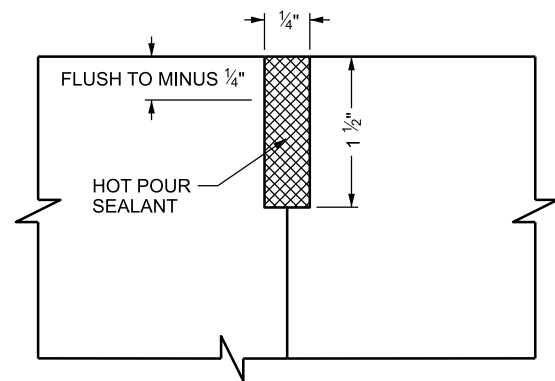

**DETAIL "C"**

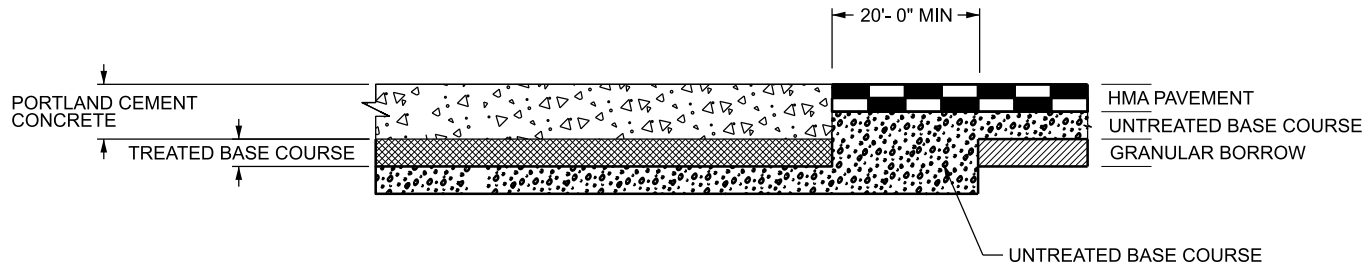

**DETAIL "E"**  
CONCRETE TO FLEXIBLE  
PAVEMENT TRANSITION

**NOTES:**  
1. DIMENSIONS MAY VARY DEPENDING ON ORIGINAL JOINT CONSTRUCTION.

REVISIONS		NO.	DATE	APPR.	REMARKS
1	10-26-17	SA			SHEET NUMBER CHANGED, NOTES

**UTAH DEPARTMENT OF TRANSPORTATION**  
STANDARD DRAWINGS FOR ROAD AND BRIDGE CONSTRUCTION  
SALT LAKE CITY, UTAH  
STANDARD DRAWING EDITION

**2024 Standard Drawing**

**CONCRETE PAVEMENT  
DETAILS 1 OF 2**

STANDARD DRAWING TITLE

STD. DWG. NO.  
**PV 2**



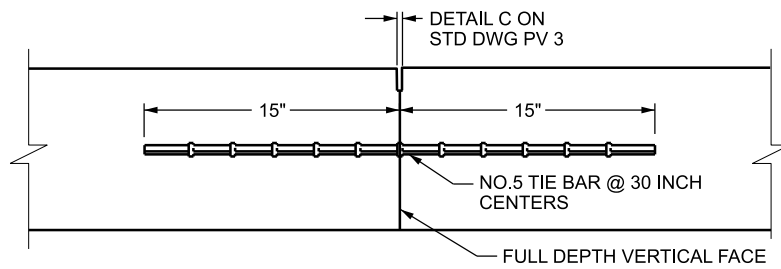

**LONGITUDINAL CONTACT JOINT  
DETAIL "A"**

NOTE: NO. 5 TIE BAR @ 15 INCH CENTERS IF DRILLED AND EPOXIED.

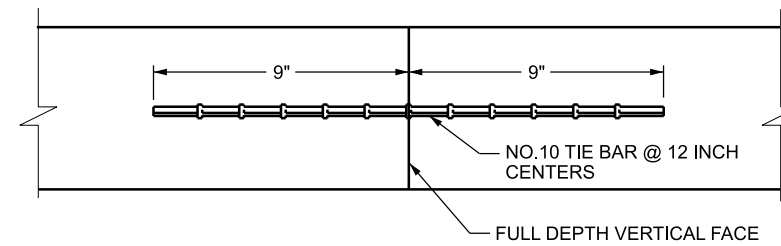

**MID-PANEL CONTACT JOINT  
DETAIL "B"**

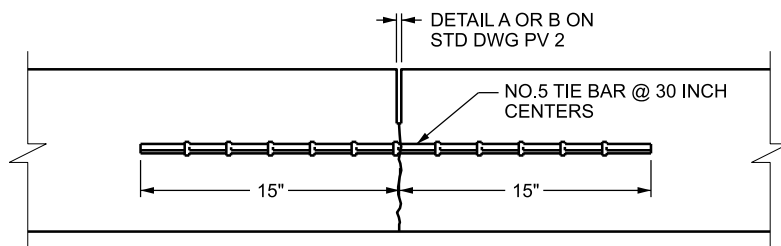

**LONGITUDINAL SAWED JOINT  
DETAIL "C"**

(T/3 SAW CUT W/ AGGREGATE INTERLOCK BELOW)

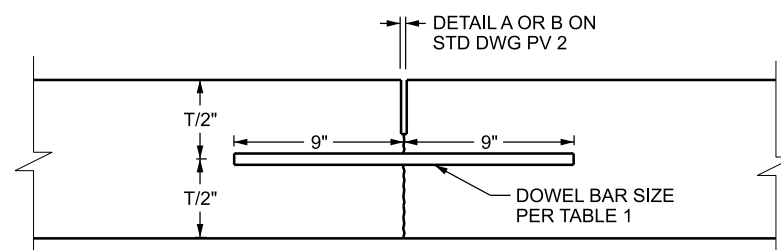

**TRANSVERSE SAWED JOINT  
(LOAD TRANSFER DOWEL BAR JOINT)  
DETAIL "D"**

INSTALL DOWEL BARS PARALLEL TO THE CENTERLINE AND TO THE PAVEMENT SURFACE. LIMIT DEVIATIONS FROM PARALLEL TO ± ¼ INCH IN THE LENGTH OF THE DOWEL BAR.

**JOINT SECTION DETAILS**

TABLE 1	
PAVEMENT THICKNESS	DOWEL BAR DIAMETER
LESS THAN 9"	1"
≥ 9" AND < 11"	1.25"
11" OR GREATER	1.5"

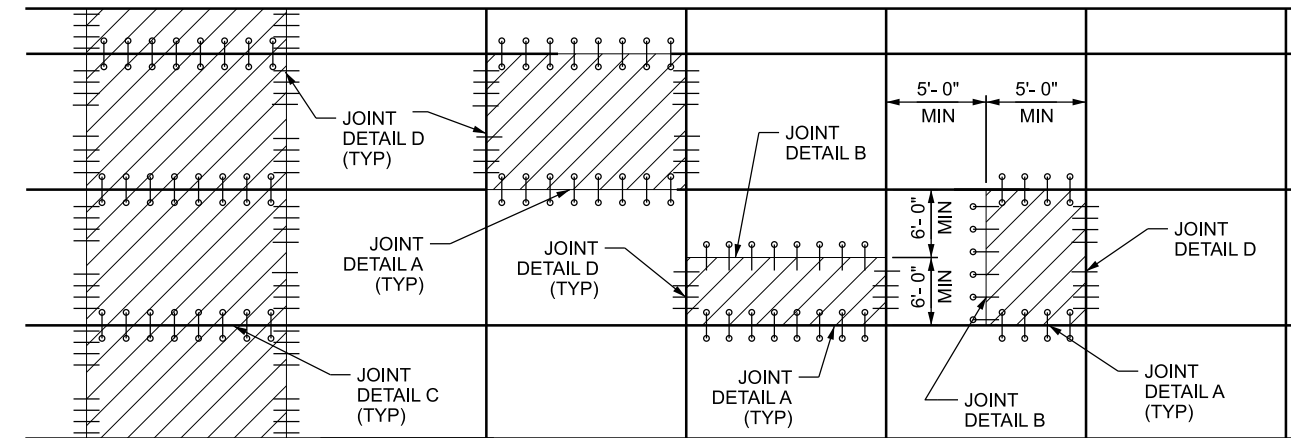

- TIE BARS - SEE DETAIL "A" OR "C"
- TIE BARS - SEE DETAIL "B"
- DOWEL BARS - SEE DETAIL "D" (4 DOWELS PER WHEEL PATH AT 12" SPACING)

**TYPICAL PAVEMENT PANEL REPLACEMENT**

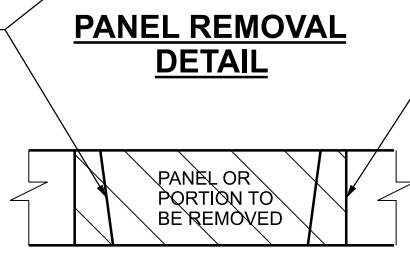
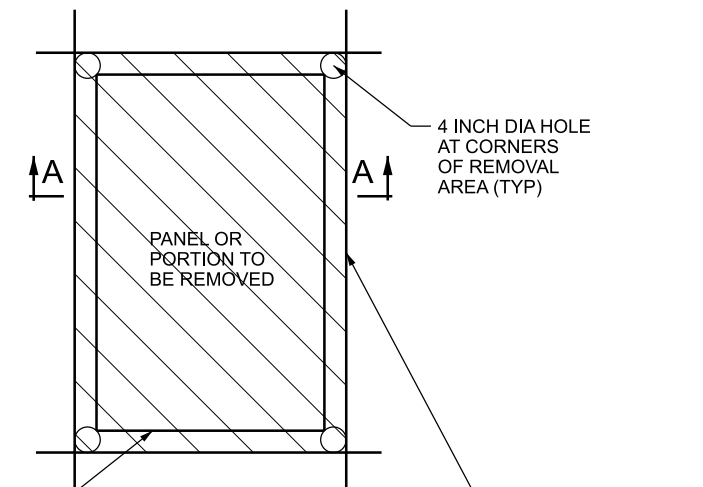

**SECTION A-A**

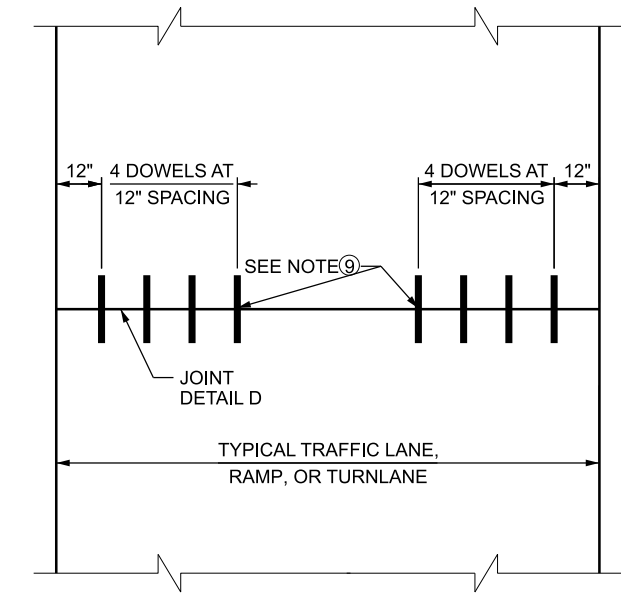

**LOAD TRANSFER DOWEL BAR LAYOUT FOR NEW PAVEMENT**

**NOTES:**

1. COAT ALL BARS ACCORDING TO STANDARD SPECIFICATION 03211.
2. USE DEFORMED REINFORCING BAR FOR TIE BARS.
3. USE SMOOTH DOWEL BARS.
4. MAKE FULL DEPTH SAWCUT AROUND ALL EDGES OF PANELS OR PORTIONS REPLACED. MINIMIZE OVERCUT INTO ADJACENT PANELS.
5. REPLACE THE ENTIRE PANEL WHEN REPLACING A PARTIAL PANEL IF THE WIDTH OF REMAINING PORTION IS LESS THAN THE MINIMUM SHOWN.
6. DO NOT INSTALL DOWEL BARS IN THE SHOULDERS UNLESS DIRECTED TO DO SO BY THE PROJECT SPECIFIC SPECIAL PROVISION OR PLAN SHEET.
7. PARTIAL PANEL REPLACEMENTS APPLY ONLY TO THE REHABILITATION OF EXISTING PAVEMENTS AND NOT TO PROJECTS CONSTRUCTING NEW OR ORIGINAL PAVEMENT. REPAIRS TO PAVEMENT ON NEW PROJECTS REQUIRE FULL PANEL REPLACEMENT.
8. ELIMINATE TIE BARS THAT INTERFERE WITH "LOAD TRANSFER DOWEL BARS".
9. THREE DOWELS, INSTEAD OF FOUR, AT 12 INCH SPACING UNDER EACH WHEEL PATH IS ACCEPTABLE, WHEN CONCRETE IS ON ASPHALT. REMOVE THE INSIDE DOWEL BAR IN EACH WHEEL PATH.

REVISIONS		NO.	DATE	APPR.	REMARKS
1	10-26-17	SA			SHEET NUMBER CHANGED, NOTES AND DETAIL TITLES CHANGED

UTAH DEPARTMENT OF TRANSPORTATION  
STANDARD DRAWINGS FOR ROAD AND BRIDGE CONSTRUCTION  
SALT LAKE CITY, UTAH  
STANDARD DRAWING EDITION

**2024 Standard Drawing**

CONCRETE PAVEMENT  
DETAILS 2 OF 2

STANDARD DRAWING TITLE

STD. DWG. NO.  
**PV 3**

5-APR-2023 D:\N\Standards\SpecSection\2024\_Standards (pub, Spring 2023)\Electronic Books\Master Drawings\Drawings\PV03.dgn

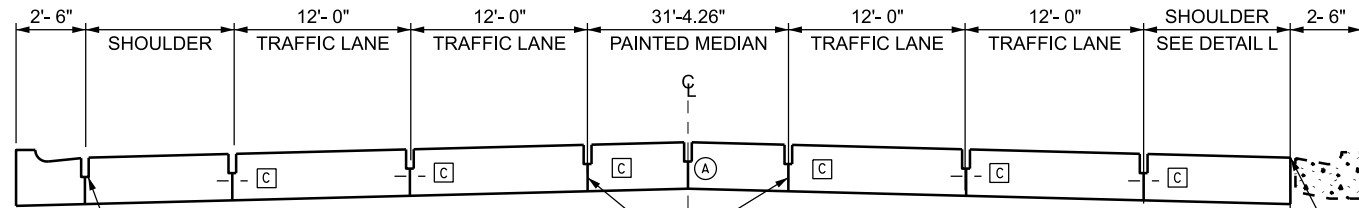

SAW CUT WHEN PLACED MONOLITHIC  
SEE DETAIL A OR B STD DWG PV 3

IF MEDIAN HALF WIDTH  
IS LESS THEN 8 FT TIE  
BARS ARE REQUIRED.

DETAIL C STD DWG PV 3  
REQUIRED WHEN NOT  
PLACED MONOLITHICALLY.

**PAVEMENT TRANSITION**

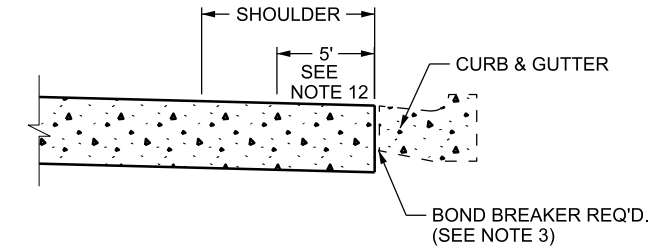

**DETAIL L**

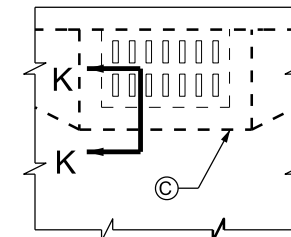

**CATCH BASIN  
DETAIL K**

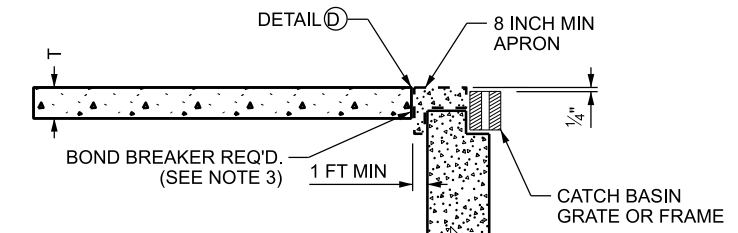

**SECTION K-K**

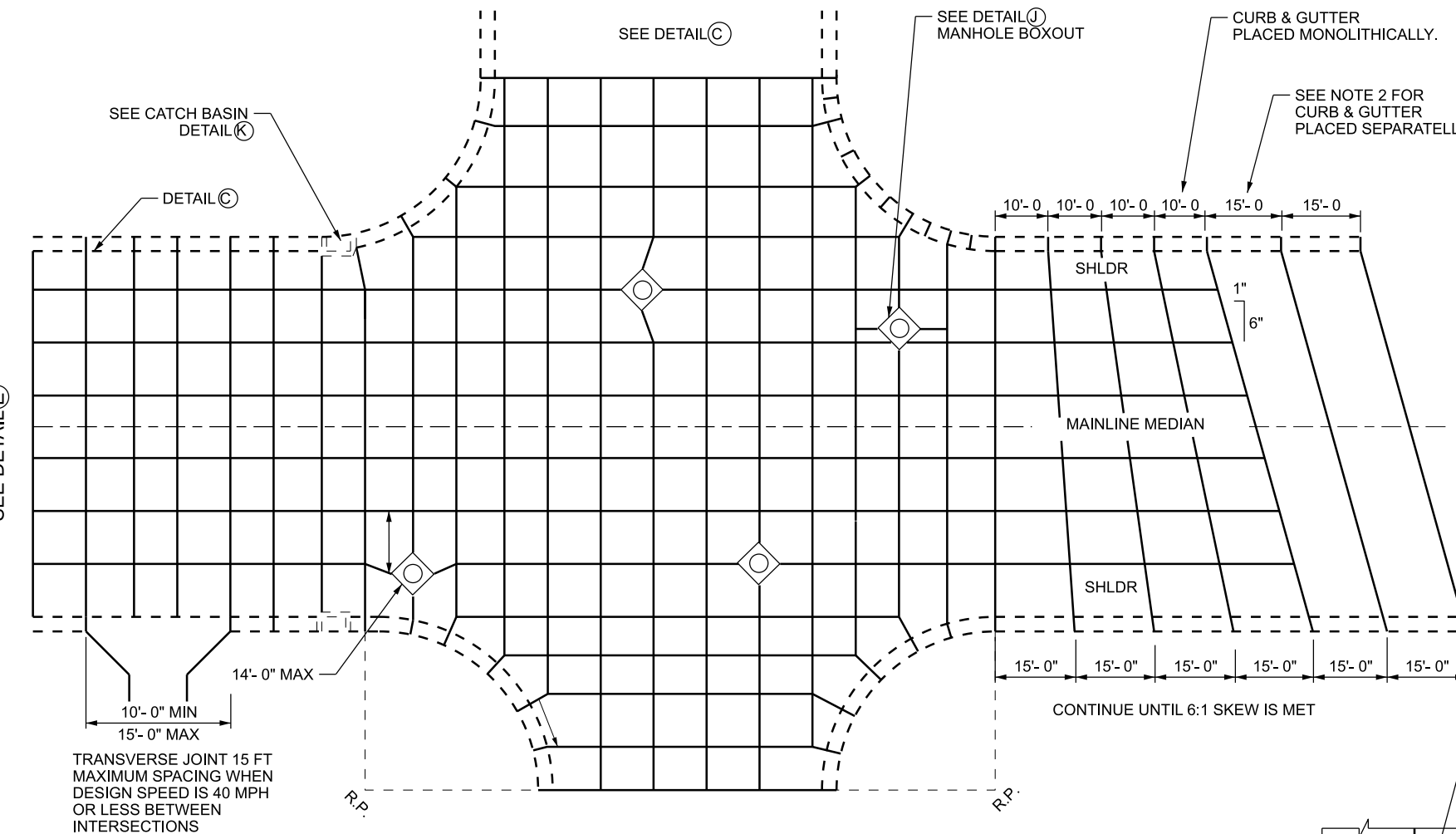

CONCRETE TO FLEXIBLE TRANSITION  
SEE DETAIL E

TRANSVERSE JOINT 15 FT  
MAXIMUM SPACING WHEN  
DESIGN SPEED IS 40 MPH  
OR LESS BETWEEN  
INTERSECTIONS

**CONCRETE TO CONCRETE TRANSITION**

SEE NOTE 7.

**INTERSECTION JOINT LAYOUT**

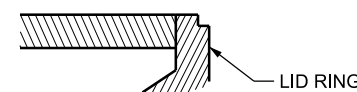

**SECTION J-J**

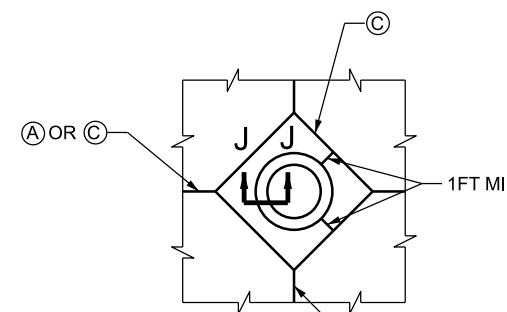

**MANHOLE BOXOUT  
DETAIL J**

**NOTES:**

1. CURB & GUTTER JOINTS TO BE CONTINUOUS WITH PAVEMENT WHEN PLACED MONOLITHICALLY WITH PAVEMENT.
2. CURB & GUTTER JOINTS NORMAL TO THE FLOWLINE AND AT ONE HALF THE PAVEMENT JOINT SPACING, WHEN PLACED SEPARATELY FROM THE PAVEMENT.
3. PLACE A BOND BREAKER AS SHOWN IN DETAIL L AND SECTION K-K WHERE CONCRETE PAVEMENT IS PLACED AGAINST EXISTING CURB & GUTTER, DRIVEWAYS AND WALKWAYS.
4. REFER TO PROJECT SPECIFICATIONS FOR JOINT INFORMATION AND DETAILS.
5. PREFERRED TRANSVERSE JOINT LOCATIONS ARE: MORE THAN 5 FT FROM LARGE APPURTENANCES WITH NO BOXOUT; OR AT THE CORNER OF RECTANGULAR BOXOUTS OR APPURTENANCES.
6. SHORTEN ONE OR MORE PANELS EITHER SIDE OF OPENING TO PERMIT JOINT TO FALL AT CORNERS OF RECTANGULAR STRUCTURES WHEN A JOINT FALLS WITHIN 5 FT OF OR CONTACTS BASINS, MANHOLES, OR OTHER STRUCTURES.
7. DETAIL C REQUIRED. WHEN CROSS STREET IS CONCRETE AND AT STRUCTURES.
8. SEE STD DWG GW 3 FOR CURB & GUTTERS DETAILS.
9. SEE STD DWG GW 6 FOR DRIVEWAY DETAILS.
10. LETTER INSIDE ○ DENOTES DETAIL, STD DWG PV 3
11. LETTER INSIDE □ DENOTES DETAIL, STD DWG PV 4
12. SLOPE OF 5 FT SECTION NEXT TO CURB AND GUTTER MAY BE STEEPENED TO MATCH LIP OF EXISTING GUTTER.

REVISIONS

NO.	DATE	APPR.	REMARKS

UTAH DEPARTMENT OF TRANSPORTATION  
STANDARD DRAWINGS FOR ROAD AND BRIDGE CONSTRUCTION  
SALT LAKE CITY, UTAH  
STANDARD DRAWING EDITION

2024 Standard Drawing

URBAN CONCRETE  
PAVEMENT DETAILS

STANDARD DRAWING TITLE

STD. DWG. NO.

PV 5



5-APR-2023 D:\N\Standards\SpecSection\2024\_Standards (pub, Spring 2023)\Electronic Books\Master Drawings\Drawings\Right\dgr

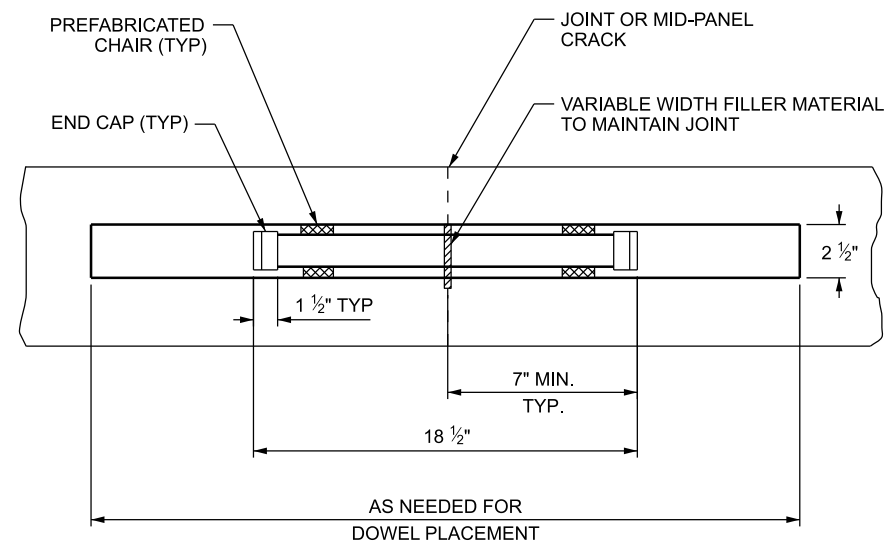

**PLAN**

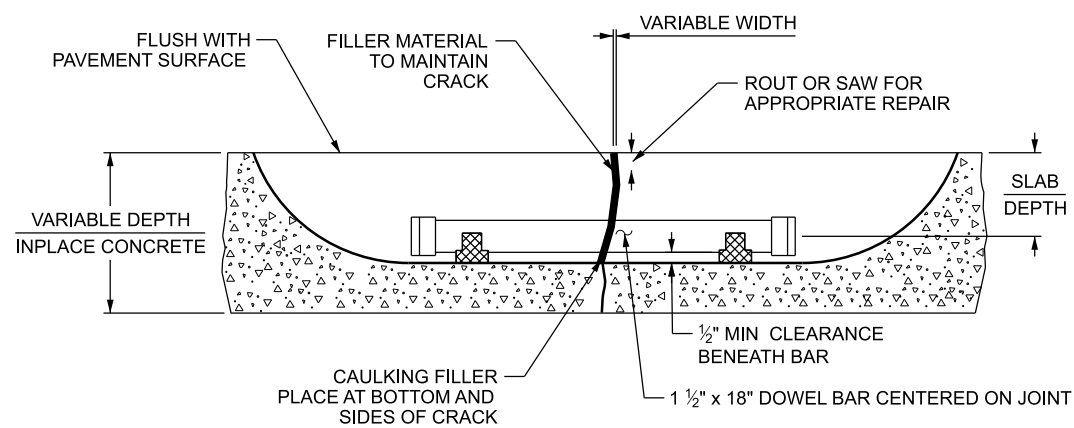

**ELEVATION**  
SEE NOTE 2

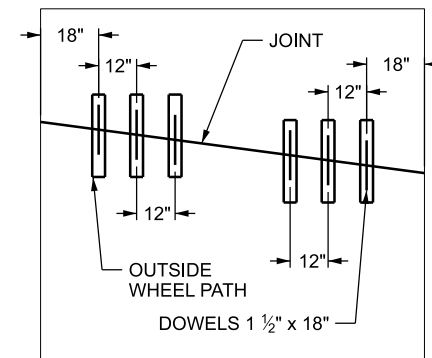

**TYPICAL LANE**  
SEE NOTES 3 & 4

**JOINT RETROFIT DOWEL LAYOUT**

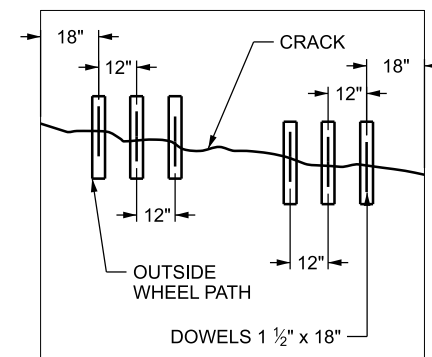

**CRACK RETROFIT DOWEL LAYOUT**  
(FOR MID-PANEL CRACK)

**NOTES:**

1. THIS REPAIR IS INTENDED TO BE USED TO ESTABLISH AND RESTORE LOAD TRANSFER AT JOINTS OR CRACKS
2. PROVIDE 1/2 INCH MINIMUM CLEARANCE AROUND BAR EXCEPT FOR DEPTH OF COVER.
3. PROVIDE DOWEL BARS PARALLEL TO THE CENTERLINE AND TO THE PAVEMENT SURFACE.
4. LIMIT DEVIATIONS FROM PARALLEL TO 1/4 INCH IN THE LENGTH OF THE DOWEL BARS.

NO.	DATE	APPR.	REMARKS

UTAH DEPARTMENT OF TRANSPORTATION  
STANDARD DRAWINGS FOR ROAD AND BRIDGE CONSTRUCTION  
SALT LAKE CITY, UTAH  
STANDARD DRAWING EDITION

DOWEL BAR RETROFIT

2024 Standard Drawing

STD. DWG. NO.  
PV 9

STANDARD DRAWING TITLE

5-APR-2023 DON\_F:\er\01\Standards\Standards\2024\_Standards (pub, Spring 2023)\Electronic Books\Wester\_Drawings\DRAWINGS\P10.dgn

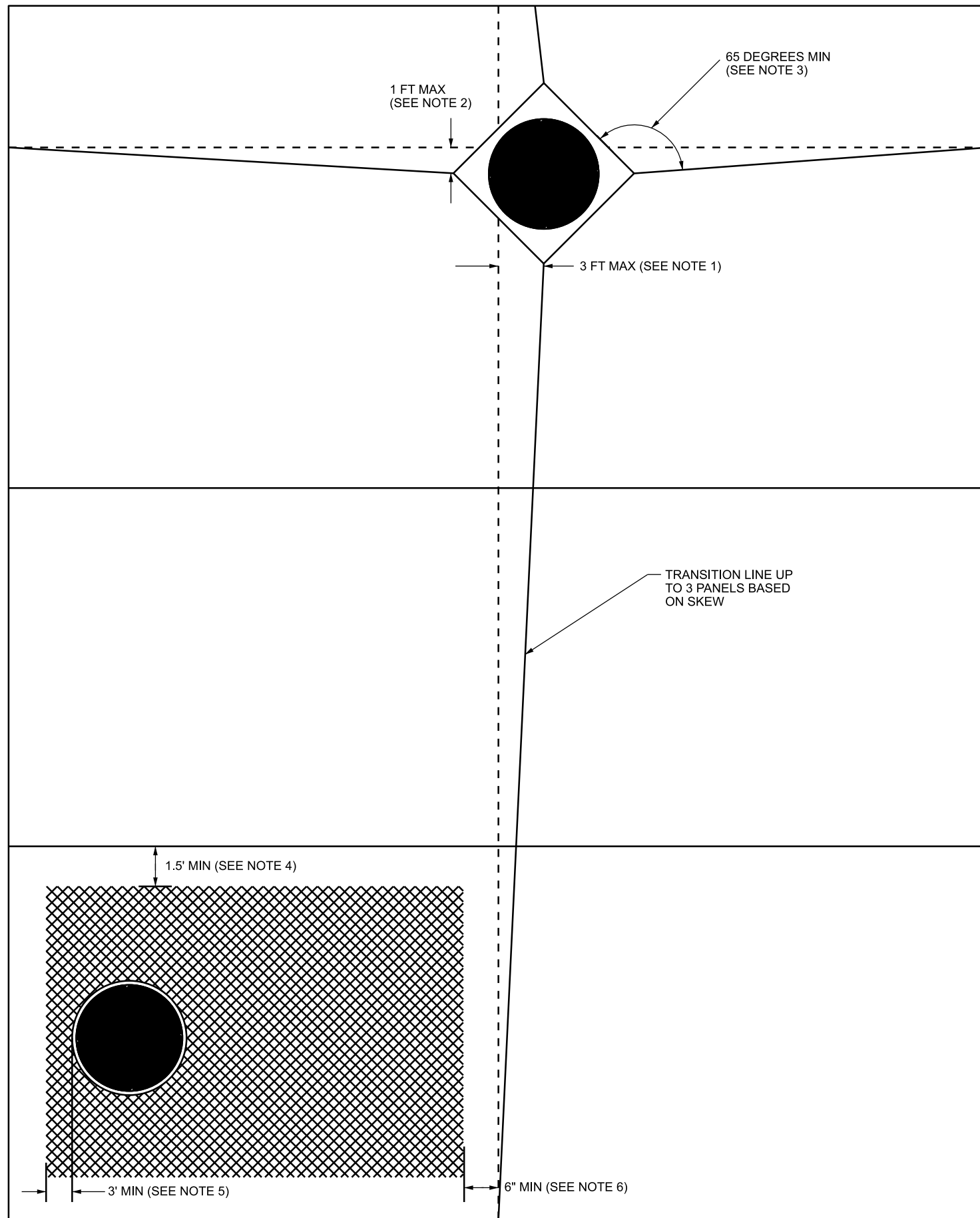

**UTILITY ORIENTATION/ADJUSTMENT OPTIONS IN PCCP**

**NOTES:**

- OPTION 1: PLACE BLOCKOUT AND ADJUST LONGITUDINAL AND TRANSVERSE JOINTS.
- 1 - LONGITUDINAL SKEW NO MORE THAN 3 FT.
  - 2 - SKEW TRANSVERSE JOINT UP TO 1 FT OVER 1 PANEL.
  - 3 - ANGLE BETWEEN TRANSVERSE JOINT AND BLOCKOUT TO BE 65 DEGREES OR GREATER.
- OPTION 2: PLACE REINFORCING MESH AROUND MANHOLE LID.
- 4 - 1.5 FT MINIMUM CLEARANCE FROM DOWELED JOINT. DO NOT PLACE MESH ACROSS TRANSVERSE JOINT.
  - 5 - 3 FT MINIMUM MESH COVERAGE FROM LID PERIMETER.
  - 6 - 6 NCES MINIMUM FROM LONGITUDINAL JOINT.
  - 7 - INSTALLATION DEPTH OF MESH IS MIDSLAB +/- 1.5 INCHES.
  - 8 - USE NO. 6 GAUGE 6 INCHES x 6 INCHES GALVANIZED MESH.

REVISIONS

NO.	DATE	APPR.	REMARKS

**UTAH DEPARTMENT OF TRANSPORTATION**  
STANDARD DRAWINGS FOR ROAD AND BRIDGE CONSTRUCTION  
SALT LAKE CITY, UTAH

STANDARD DRAWING EDITION

**2024 Standard Drawing**

**UTILITY ORIENTATION/  
ADJUSTMENT OPTIONS  
IN PCCP**

STANDARD DRAWING TITLE

STD. DWG. NO.

**PV 10**