

## JORDAN VALLEY WATER CONSERVANCY DISTRICT

### Deep Well # 6 Underground Well Improvements

1/13/2022

**DESCRIPTION OF WORK:** JWCD Deep Well 6 was originally designed with an enclosed tube bearing lubrication system. The District desires to modify the underground well equipment to a “product lubed” design while reusing the stainless steel pump. The shafting and pump are currently pulled awaiting these modifications.

**PROJECT SCHEDULE:** The work shall be completed within 90 calendar days from the date of acceptance of the Award of Purchase Order. If the work is not completed within the specified time frame, the bidder herein agrees to accept liquidated damages in the amount of \$200 per day.

**OBTAINING CONTRACT DOCUMENTS:** The Contract Documents are entitled: "Deep Well # 6 Underground Well Improvements". All Contract Documents may be obtained on the District's website ([www.jvwcd.org](http://www.jvwcd.org)) beginning **January 12, 2022**.

**PRE-BID SITE VISIT:** A non-mandatory pre-bid site visit will be held at the site of the work on Thursday **January 25, 2021 at 3:30 pm** for interested contractors.

**RECEIPT OF BIDS:** Bids will be received by Jordan Valley Water Conservancy District, attention David McLean at 8215 South 1300 West, West Jordan, Utah 84088, or via email to [ellisad@jvwcd.org](mailto:ellisad@jvwcd.org) until 4:00 pm on **February 3, 2022**. Bid amounts will be listed on [jvwcd.org](http://jvwcd.org) after the bid acceptance deadline. Bidders need not be present at the public bid opening.

**PROJECT REGISTRATION:** Prospective bidders must register at the District's web site under the project to receive project notifications and addenda, if any. Contractors are required to check the District's web site for any addenda prior to submitting a responsive bid. Bids determined to be non-responsive may be rejected.

JVWCD project manager/contact person: David McLean, PE  
Telephone Number: (801) 565-4300

**SITE OF WORK:** 9940 South 2700 West, West Jordan, Utah

**AWARD OF CONTRACT:** An Award of Contract, if awarded, will be made within 30 calendar days of the opening of bids. Contract will be awarded based upon the lowest cost responsive bid.

**BONDS:** Bid bonds and Performance Bonds will be required for any bid with a total cost exceeding \$50,000.

**BIDDER REQUIREMENTS:** The bidder shall have a valid Utah Business license and a valid Utah Contractors license appropriate for the work. The successful bidder will have completed a minimum of three projects of similar nature within the last ten years.

<u>Job Name/Description</u>	<u>Contact</u>
1.	
2.	
3.	

The Owner may contact each reference listed by the contractor.

**ADDRESS AND MARKING OF BID:** The envelope enclosing the bid shall be sealed and addressed to the Jordan Valley Water Conservancy District and delivered or mailed to 8215 South 1300 West, West Jordan, Utah 84088. The envelope shall be plainly marked in the upper left-hand corner with the name and address of the bidder and shall bear the words "Bid for," followed by the title of the Contract Documents for the work and the date and hour of opening of bids. Electronic bids shall be submitted to the project manager as an email attachment with the words "Bid for," followed by the title of the Contract Documents for the work and the date and hour of opening of bids in the subject line of the email.

**PROJECT ADMINISTRATION:** All questions relative to this project prior to the opening of bids shall be directed to the Project Manager for the project.

**OWNER'S RIGHTS RESERVED:** The Owner reserves the right to reject any or all bids, to waive any informality in a bid, and to make awards in the interest of the Owner.

Owner/ Engineer  
Jordan Valley Water Conservancy District  
Project Manager: David McLean, PE  
8215 South 1300 West  
West Jordan, Utah 84088  
Telephone: (801) 565-4300  
Email: dmclean@jvwcd.org

JORDAN VALLEY WATER CONSERVANCY DISTRICT



**BID SCHEDULE A**

Bidder (Company name): \_\_\_\_\_

By: \_\_\_\_\_  
(Signature)

Dated: \_\_\_\_\_

Name: \_\_\_\_\_  
(Print)

Title: \_\_\_\_\_

The Bidder shall furnish the following information. Failure to comply with this requirement may render the Bid non-responsive and subject to rejection. Additional sheets shall be attached as required. No bid for the work will be considered from a bidder who does not hold an active license in good standing applicable to the type of work bid upon at the time of submission of the bid.

1. Contractor's name: \_\_\_\_\_

2. Contractor's address: \_\_\_\_\_  
\_\_\_\_\_  
\_\_\_\_\_

Contractor's Primary Contact: \_\_\_\_\_

Email address of Contractor's primary contact: \_\_\_\_\_

Contractor's telephone number: \_\_\_\_\_

3. Utah Department of Commerce Information  
Business Entity Number: \_\_\_\_\_  
Delinquent Date: \_\_\_\_\_

4. Contractor's Utah License Number: \_\_\_\_\_  
Expiration Date: \_\_\_\_\_  
Primary Classification: \_\_\_\_\_  
Supplemental Classification held, if any: \_\_\_\_\_

5. Number of years as a contractor in work of this type:  
\_\_\_\_\_

6. As necessary, attach to your bid technical information showing compliance with the defined scope of work and/or technical specifications.

7. As necessary, attach to your bid technical information showing compliance with the defined scope of work and/or technical specifications.



**DOCUMENT 00 41 00  
BID FORM**

**Jordan Valley Water Conservancy District  
Deep Well 6 Underground Well Improvements**

1.01 Unit Price Bids

A. Bidder will perform the following Work at the indicated unit prices:

Item No.	Description	Unit	Estimated Quantity	Bid Unit Price	Bid Amount
1	Mobilization / Demobilization	LS	1	\$	\$
2	Dual Swab Development	HR	80	\$	\$
3	Convert to Product Lubricated Pump System	LS	1	\$	\$
4	Modify Each Existing 8-Inch 316 SS Column Pipe Section	EA	11	\$	\$
5	Replace Fiberglass Reinforced Column Pipe (FRP) with New 8-Inch 316 SS Pipe	LF	183	\$	\$
6	Replace Column Shaft with New 316 SS Shaft	LF	390	\$	\$
7	New Column and Shaft Bearings	LS	1	\$	\$
8	Upgrade Pump Shaft Bearings to Stainless Steel Marine Rated	LS	1	\$	\$
9	Reinstall Permanent Pumping Equipment	LS	1	\$	\$
Total of All Bid Items:					\$
Total Unit Price Base Bid (in words): _____					

**AWARD OF PURCHASE ORDER**

The Jordan Valley Water Conservancy District (Owner) hereby accepts your Bid dated \_\_\_\_\_ . In accordance with your Bid and the Owner’s Contract Documents dated \_\_\_\_\_, the Owner has created a purchase order in the amount of \$\_\_\_\_\_ for the project entitled “\_\_\_\_\_”. The completion date is \_\_\_\_ calendar days from the Acceptance Date of this Award by you.

You should sign and return this Award of Purchase Order within 10 calendar days from the date of this notice to you.

Sincerely,

Alan E. Packard, PE  
Assistant General Manager and Chief Engineer

\_\_\_\_\_  
Award Date

**ACCEPTANCE OF AWARD**

\_\_\_\_\_, a corporation qualified to do business in the State of Utah, hereby agrees to perform as specified in its Bid, the Owner’s Contract Documents, and this Award of Purchase Order.

\_\_\_\_\_

\_\_\_\_\_  
Signature

\_\_\_\_\_  
Title

\_\_\_\_\_  
Acceptance Date

Attachments: Bid



CRS Engineers PN 2020-0326  
4246 S. Riverboat Rd, Ste 200, Salt Lake City, UT 84123

Jordan Valley Water Conservancy District

## **Deep Well 6 Underground Well Improvements**

Project Location:

8215 S 1300 W, West Jordan, Utah

January 2022

# TECHNICAL SPECIFICATIONS

---

# CONTENTS

---



<b>DIVISION 1</b>	01 02 50	Measurement and Payment
GENERAL REQUIREMENTS	01 74 15	Mobilization / Demobilization / Cleanup
WELL REHAB AND DRILLING	33 01 25	Well Redevelopment
	33 11 23	Deep Well Vertical Turbine Pump, Motor, and Appurtenances
	33 20 61	Disposal of Drilling Fluids, Cuttings, and Pumped Water



## SECTION 01 02 50 MEASUREMENT AND PAYMENT

### PART 1 - GENERAL

#### 1.1 SECTION INCLUDES

- A. Measurement and payment criteria applicable to portions of the Work performed under a unit price payment method.

#### 1.2 RELATED SPECIFICATIONS

- A. Bid
- B. Agreement, Article V – Payment Procedures

#### 1.3 MEASUREMENT OF QUANTITIES

- A. Measurement Devices:
  1. Weigh Scales: Inspected, tested and certified by the applicable state Weights and Measures department within the past year.
  2. Platform Scales: Of sufficient size and capacity to accommodate the conveying vehicle.
  3. Metering Devices: Inspected, tested and certified by the applicable State department within the past year.

#### 1.4 PAYMENT

- A. Payment for each Bid item includes full compensation for all required labor, materials, products, tools, equipment, manufacturing, transportation, services, and incidentals; application or installation; permits, taxes, royalties, import costs, overhead and profit.

#### 1.5 DESCRIPTION OF BID ITEMS

- A. The work generally consists of the following, which are numbered according to the Bid schedule found in the Bid Form:

1. **Mobilization / Demobilization** - Measurement and Payment shall be made by the lump sum and lump sum price shown on the bid schedule. Payment covers:
  - a. Payment covers cost of mobilization, demobilization, installation of temporary facilities, bringing all necessary construction equipment to the site, all bonds, insurances, permits and fees, traffic control, clearing and grubbing, snow removal to the well site, quality control of materials, preparation of project schedule, final cleanup and project closeout, and all other items not specifically called for in any other bid item or called for in the plans and specifications or is customary, incidental or appurtenant to performance of a complete project.
  - b. Payment will be made according to the following schedule:

Percent of Original Contract <u>Amount Earned</u>	Percent of Amount Bid for <u>Mobilization to be Paid</u>
5%	40
15%	20



40%	30
50%	10

2. **Dual Swab Development** - Measurement and Payment shall be made on an hourly basis and unit price shown on the bid schedule. Payment covers:
  - a. Dual swabbing with cable tool rig for a minimum of one pass down and up of the entire well depth and thereafter of all screened sections of the well.
  - b. Spending all the necessary time developing the sections specified in the well that produce more sand than others according to the Engineer's direction.
  - c. All pumping and temporary pump equipment.
  - d. All bailing and removing of pumped material.
3. **Convert to Product Lubricated Pump System** – Measurement and Payment shall be made by the lump sum and lump sum price shown on the bid schedule. Payment covers:
  - a. Disconnecting the existing pump lubrication system and all appurtenances (Pump already pulled by others).
  - b. Reconfiguring existing pump lubrication system to include new 1/2-inch soldered copper piping with foam insulator with salvaged backflow preventer, strainer, solenoid valve, pressure gauge, bypass line with ball valve, and pressure sensor in line as shown in the drawings.
  - c. All required testing of product lubrication system
4. **Modify Each Existing 8-Inch 316 SS Column Pipe Section** – Measurement and Payment shall be made for each 20-foot section of existing 8-Inch SS column pipe successfully modified to be reconfigured in new design and unit price shown on the bid schedule. Payment covers:
  - a. Cutting each existing 20-foot section of 8-Inch stainless-steel column pipe in half to make 10-foot lengths each.
  - b. Purchase and weld new stainless-steel flanged ends onto newly cut column pipe to match diameter and bolt holes as existing.
  - c. Modify column flanges (every 10-feet) with recession to house new stainless-steel bearing retainers.
5. **Replace Fiberglass Reinforced Column Pipe (FRP) with New 8-Inch 316 SS Pipe** – Measurement and Payment shall be made on a linear foot basis and unit price shown on the bid schedule. Payment covers:
  - a. Removing and disposing of existing Fiberglass Reinforced Column pipe (FRP) currently stored on site.
  - b. Purchasing and storing new 8-inch 316 stainless steel flanged column pipe.
  - c. Payment shall be made for the actual linear feet of new stainless-steel column pipe purchased and delivered to the site.
6. **Replace Column Shaft with New 316 SS Shaft** – Measurement and Payment shall be made on a linear foot basis and unit price shown on the bid schedule. Payment covers:
  - a. Removing and disposing of existing steel column shaft currently stored on site.
  - b. Purchasing and storing new 1 1/2-Inch 316 stainless-steel column shaft in 10-foot lengths.
  - c. Payment shall be made for the actual cost of stainless-steel shaft pipe purchased.
7. **New Column and Shaft Bearings** – Measurement and Payment shall be made on a lump sum basis and lump sum price shown on the bid schedule. Payment covers:
  - a. Removing and disposing of existing bronze bearings in tube assembly currently stored on site.



- b. Purchasing and storing new neoprene fluted bearings for the column shaft and new stainless-steel bearing retainers for the column pipe flanges.
  - c. Payment shall be made for the actual cost of bearings and retainers purchased for the column and shaft.
8. **Upgrade Pump Shaft Bearings to Stainless Steel Marine Rated** – Measurement and Payment shall be made on a lump sum basis and lump sum price shown on the bid schedule. Payment covers:
- a. Removing and disposing of existing bronze bearings from pump bowl shaft assembly currently stored on site.
  - b. Purchasing and installing new stainless-steel marine rated bearings for pump bowl shaft.
  - c. Payment shall be made for the actual cost of marine rated bearings purchased and installed to fit pump bowl shaft.
9. **Reinstall Permanent Pumping Equipment** – Measurement and Payment shall be made by the lump sum and lump sum price shown on the bid schedule. Payment covers:
- a. Cleaning pump bowl assembly and column pipe to be reused.
  - b. Reinstallation of existing modified pump with 205-feet of modified stainless-steel column pipe and 183-feet of new stainless-steel column pipe with 388-feet of new stainless-steel column shaft with new bearings and retainers.
  - c. Reinstallation of existing vertical turbine motor and well head.
  - d. Connection of new product lube system to well head.
  - e. Reconnection of all electrical systems.
  - f. Well startup and all required testing of the well pumping system.

**END OF SECTION**



*THIS PAGE HAS BEEN LEFT BLANK INTENTIONALLY*



## SECTION 01 74 15 MOBILIZATION / DEMOBILIZATION / CLEANUP

### PART 1 - GENERAL

#### 1.1 SECTION INCLUDES

- A. Work to be performed under this Section includes the work necessary to mobilize, demobilize, and clean up the well site involving re-development of the production wells.

#### 1.2 RELATED WORK

Not Used.

#### 1.3 REFERENCES

Not Used.

#### 1.4 SUBMITTALS

Not Used.

### PART 2 - PRODUCTS

#### 2.1 GENERAL

- A. Provide all temporary and permanent materials, equipment, and labor required to accomplish the work as specified.

#### 2.2 SECURITY FENCE

- A. A security fence with locking gate exists on the west side of the project site adjacent to 2700 W. Owner shall provide contractor with a key to the gate. The gate shall remain locked at any time Contractor is not on site.
- B. The Contractor shall provide access at any time and any necessary keys to the Engineer.

#### 2.3 PARKING FACILITIES

- A. Parking facilities for personnel working on the project will be limited. Contractor shall maintain the access road to the well site open at all times.

#### 2.4 NOISE CONTROL FACILITIES

- A. Where applicable, the Contractor will obtain a noise permit from the Salt Lake County Health Department (SLCHD) and South Jordan City. The Contractor will be fully responsible for compliance to the permit and the Contractor shall demonstrate compliance with the noise control requirements.
- B. Diesel engine acoustical enclosure of steel framed, fiberglass filled panels shall be required for all drill rigs, compressors and pumps. Where these engines are not properly isolated to prevent noise in the supporting structure, this secondary noise shall be mitigated such as by the use of acoustical skirts for drill rig trailers. High performance mufflers shall be used on all diesel engines in regular use on the wellsite.
- C. Noise barrier walls shall be constructed where required to meet sound regulations found in the SLCHD ordinance to mitigate noise. The noise barrier walls shall consist of fiberglass filled acoustical walls, or equal, and have a minimum wall height of 20 feet. The noise barrier walls shall reduce the maximum continuous noise from drilling operations to less than 60 dB at 50



feet around the perimeter of the drill site, or to levels designated in the noise permit, whichever is stricter.

### **PART 3 - EXECUTION**

#### **3.1 WELL MAINTENANCE**

- A. Set up well maintenance and related other equipment within the area designated by the Engineer. Accomplish all required work in accordance with applicable portions of these Specifications.

#### **3.2 CONSTRUCTION LAYOUT**

- A. Set up construction facilities in a neat and orderly manner within designated area. Accomplish all required work in accordance with applicable portions of these Specifications. Confine operations to work area shown.
- B. Some obstructions may not be shown. Bidders are advised to carefully observe the existing facilities before preparing their bids. The removal and replacement of obstructions such as electrical conduits, water, waste piping, and similar items shall be anticipated and accomplished even though not shown or specifically mentioned.
- C. Major obstructions encountered that are not shown on the Drawings or could not have been foreseen by visual observation of the site prior to bidding, should immediately be brought to the attention of the Engineer. The Engineer will make a determination for proceeding with the work.

#### **3.3 CONTAMINATION PRECAUTIONS**

- A. Avoid contamination of the project area. Do not dump waste oil, rubbish, or other materials on the ground.

#### **3.4 DISPOSAL OF MATERIAL**

- A. The Contractor shall be responsible for disposal of all drilling fluids, drill cuttings, development water, and test waters as further described in these Specifications.

#### **3.5 CLEANUP OF CONSTRUCTION AREAS**

- A. During execution of the work, the Contractor shall daily clean the site, adjacent properties, and public access roads and dispose of waste materials, debris, and rubbish to assure that grounds, and public and private properties are maintained free from accumulations of waste materials and rubbish. Contractor will provide container for collection and disposal of waste materials, rubbish, and debris.
- B. Upon completion and acceptance of the well, remove from the site the drill rig and related equipment and all debris, unused materials, temporary construction buildings, and other miscellaneous items resulting from or used in the operations. Replace and repair any facility that has been damaged during the construction work. Restore the site as nearly as possible to its original condition.

#### **3.6 NOISE CONTROL**

- A. The Contractor shall demonstrate compliance with the noise control requirements. Noise levels shall be monitored at least once daily, and at the request of the Engineer, during a time when onsite equipment is in use and noise levels are expected to be the highest. Noise levels shall be measured next to the drill site boundary and at 50 and 100 feet from the drill site using a calibrated and certified sound level meter furnished by the Contractor and kept on site at all times. Noise levels will also be measured at the property boundary.
- B. If, at any time, the noise limits are exceeded, immediate corrective action shall be taken through drilling equipment modifications, addition of noise abatement equipment or changes



in operating procedures. Noise levels shall be monitored to demonstrate compliance.

**END OF SECTION**





*This page has been left blank intentionally.*



## SECTION 33 01 25 WELL REDEVELOPMENT

### PART 1 - GENERAL

#### 1.1 SECTION INCLUDES

- A. Work to be performed under this Section includes the labor, supplies, tools, materials, and equipment necessary for the redevelopment of the production well using the dual swab tool or other Engineer approved development method.

#### 1.2 RELATED WORK

- A. Section 33 20 61 – Disposal of Drilling Fluids, Cuttings and Pumped Water. Dispose of water and residual drilling fluids generated during surge block and air lift or submersible pump development as specified herein.

#### 1.3 REFERENCES

- A. Groundwater and Wells, Second Edition, Pages 507 and 515 (by Fletcher G. Driscoll, 1986, published by Johnson Division, St. Paul, Minnesota 55112).

#### 1.4 SUBMITTALS

- A. Submittals shall include but are not limited to:
  - a. Dual rubber swab
  - b. Well development log

#### 1.5 REDEVELOPMENT TIME

- A. The total redevelopment time is estimated to be 80 hours using the dual swab tool. However, the Engineer shall be the sole judge as to when development is complete and may therefore increase or decrease the total development time.

#### 1.6 NOTIFICATION OF THE ENGINEER

- A. The Contractor shall be responsible to give the Engineer 24-hour advance notice prior to beginning well development by surge block and submersible pump for the well.

### PART 2 - PRODUCTS

#### 2.1 GENERAL

- A. Provide all temporary and permanent materials, supplies, tools, equipment, and labor required to accomplish the work as specified.

#### 2.2 SURGING AND BAILING EQUIPMENT

- A. Furnish a surge block consisting of a double rubber swab, submersible pump system, and all necessary appurtenant equipment necessary for developing the well. The swab shall be of sufficient thickness, stiffness, and size to effectively agitate the well. The rubber swab shall be at least 1-inch thick and sized to be 1/2-inch smaller diameter than the well.

#### 2.3 SAND CONTENT MEASURING DEVICE

- A. Provide a sand content measuring device such as an Imhoff cone, Rossum centrifugal sand tester, or equal.



## PART 3 - EXECUTION

### 3.1 GENERAL

- A. Contractor shall notify the Engineer and make the necessary arrangements for conducting well development. The time required for development will be recorded by the hour with one-half hour intervals as the smallest units of time credited to the Contractor. Fractions of an hour less than one-half hour but exceeding one quarter hour will be considered to be one-half hour. Fractions of an hour less than one hour but exceeding three-quarters of an hour will be considered to be one full hour.
- B. The time to be recorded for well development shall commence when the equipment is installed in the well and is placed in operation and shall end when development pumping or testing is stopped at the direction of the Engineer. No time will be recorded for delays resulting from equipment stuck in the hole; equipment breakdown; arranging major drilling, pumping or testing apparatus; or failure to conduct the operations in a diligent and workmanlike manner by which the desired results could ordinarily be expected.
- C. The Contractor may be required to add a mud dispersant to aid in removal of any clay particles. Drilling mud dispersants shall be purchased and provided by the Owner. The method for adding the chemical to the well shall be developed by the Contractor and approved by the Engineer.

### 3.2 SURGE BLOCK AND SUBMERSIBLE PUMP DEVELOPMENT USING CABLE TOOL RIG

- A. The Contractor shall commence development with the cable tool rig or approved equal.
- B. Development shall consist of swabbing with a dual swab while simultaneously pumping with a submersible pump with the capacity of 150 gpm provided by the Contractor.
- C. The clay dispersant additive (e.g., NW-220 or approved equal), if required, shall be introduced into the well via a tremie pipe or perforated surge block at three different depths specified by the Engineer. The Contractor shall mix and agitate the additive into the well by swabbing with the surge block. The additive will be allowed to sit in the well for a period of 24 hours and subsequently removed by pumping. No standby charges will be allowed for the 24 hour period the clay dispersant must sit in the well.
- D. Surging shall begin at the top of the well and continuously downward to the base of the well, making one complete pass through both closed-wrapped and open-wrapped screens. The well shall be surged using the spudding action of a cable tool drilling rig. The length of surge strokes and approximate number of strokes per minute shall be recorded by the Contractor on a field log sheet.
- E. A submersible electric pumping system capable of producing a minimum of 150 gallons per minute under conditions existing at the site shall be used to remove water and solids from the well. The Contractor shall supply and install temporary discharge piping of sufficient size and length to conduct water to holding tanks and then to the discharge point shown in the drawings.
- F. A surge block shall consist of a dual rubber swab assembly with two (2) swabs on a 4-inch minimum pipe separated by a 10-foot section of perforated drill pipe. Sufficient perforations shall be drilled between the surge blocks for passage of at least 600 gpm. There shall be a minimum of twenty 1-inch minimum diameter holes in the pipe, between the swabs. The rubber swabs shall fit snugly in the well so as to minimize leakage around the swabs. For an example of a dual rubber swab, refer to Groundwater and Wells, Second Edition, Pages 507 and 515 (by Fletcher G. Driscoll, 1986, published by Johnson Division, St. Paul, Minnesota 55112).
- G. Pumping and surging shall continue after the first pass only in the open-wrapped screened sections of the well until all sand, silt, mud, and other solids have been removed from the treatment interval or as directed by the Engineer. Multiple development passes shall be used as directed by the Engineer. Pumping and surging shall begin at the top of the perforated



- interval and work downward to the bottom of the lower-screened interval. The quality, quantity and type of solids removed from the well shall be recorded by the Contractor.
- H. Solids settling is required before the water is discharged from the surface storage tank, as well as adherence to other State of Utah Division of Water Quality requirements. Contractor shall follow Division of Water Quality BMP's which can be found on their website.
  - I. Periodically, the Contractor shall measure and pump from the well all sand, silt, and clay that has accumulated at the bottom. Development shall be continued until all fines and sand have been removed from the well. Upon completion of this operation, the well shall be pumped clean of all accumulations of mud, sand, rock, or sediment to its full depth prior to commencing the pumping of the well.
  - J. Sand measurements shall be made with a Imhoff cone or Rossum centrifugal sand tester during cable tool development pumping.
  - K. The total amount of material removed from the well during rehabilitation shall be recorded in the development log.

**END OF SECTION**



*This page has been left blank intentionally.*



## SECTION 33 11 23 DEEP WELL VERTICAL TURBINE PUMP, MOTOR, AND APPURTENANCES

### PART 1 - GENERAL

#### 1.1 SECTION INCLUDES

- A. Modifying existing pump equipment for a water lubricated surface discharge deep well turbine pump.

#### 1.2 RELATED WORK

- A. None.

#### 1.3 REFERENCES

- A. American Water Works Association (AWWA)
  - 1. ANSI/AWWA E101 – Standard for Vertical Turbine Pumps
- B. Hydraulic Institute Standards
- C. ASTM International
  - 1. ASTM A48 – Standard Specification for Gray Iron Castings
  - 2. ASTM A53 – Standard Specification for Pipe, Steel, Black and Hot-Dipped, Zinc-Coating, Welded and Seamless
  - 3. ASTM A108 – Standard Specification for Steel Bar, Carbon and Alloy, Cold-Finished
  - 4. ASTM A269 – Standard Specification for Seamless and Welded Austenitic Stainless-Steel Tubing for General Service
  - 5. ASTM A276 – Standard Specification for Stainless Steel Bars and Shapes
  - 6. ASTM B505 – Standard Specification for Copper Alloy Continuous Castings
  - 7. ASTM B584 – Standard Specifications for Copper Alloy Sand Castings for General Applications
  - 8. ASTM F480 – Standard Specification for Thermoplastic Well Casing Pipe and Couplings Made in Standard Dimension Ratios (SDR), SCH 40 and SCH 80
- D. ANSI/NSF 61 – Drinking Water System Components - Health Effects

#### 1.4 DESIGN CRITERIA

- A. General.
- B. Operating Capacities
 

Pump Intake Setting Depth	395 Feet Below Ground Surface
Column Size	8" Diameter x 10' Lengths
Shaft Size	1 1/2" Diameter x 10' Lengths

#### 1.5 SUPPLIER QUALIFICATIONS

- A. The supplier of the column pipe, shaft, and bearings shall have been in business for not less than 10 years. The primary function of the supplier shall be water well pumps and motors. This supplier shall have sole responsibility for all materials contained within this specification section.



## PART 2 - PRODUCTS

### 2.1 PUMP BOWL ASSEMBLY

- A. The existing pump bowl assembly shall be reused, and new stainless steel backed marine bearings shall be installed in the pump bowls replacing the existing ones.

### 2.2 COLUMN ASSEMBLY

- A. New 316 stainless steel lineshaft, in 10-foot lengths, shall be purchased and installed with the modified stainless steel column pipe.
- B. The existing line shaft bearings shall be replaced with new fluted neoprene bearings at every joint. The line shaft shall be stabilized and centered in the column pipe by stainless steel bearing retainers spaced 10-feet from the top and bottom, and at 10-foot intervals throughout the balance of the column pipe.
- C. The existing shaft tubes shall be disposed of properly and will not be installed as the well will be converted to a top-feed product pre-lube system.
- D. The existing stainless steel column pipe shall be reused and modified to be installed in 10-foot lengths. Each existing 20-foot section of stainless-steel column pipe shall be cut in half and flanged ends shall be welded onto each cut end to match diameter and thickness of existing flanges. The existing Fiberglass Reinforced Pipe (FRP) above the water level shall be disposed of and replaced as shown in the drawings. The new outer column pipe shall be of 316 stainless-steel pipe in interchangeable sections not over 10 feet in length and with the ends of each section with welded flange connection to match existing. The weight of the column pipe shall be no less than that stated in ANSI Specification E101, Section 5.1 "Standard Specifications for Discharge Column Pipe."
- E. The replacement column pipe sections shall match the measurements of the existing column.
- F. New column pipe sections to have flanges with female recess to fit new stainless-steel bearing retainers. Modify existing flanges that have male registers to female registers in order to accommodate product lubricated bearing retainers. Install new bearing retainers with fluted neoprene bearings at each column joint with a maximum spacing of 10 feet.

## PART 3 - EXECUTION

### 3.1 INSTALLATION

- A. Installation shall meet manufacturers requirements.
- B. Install a pre-lube system going into the discharge head with a solenoid valve that will turn on 5-minutes prior to the pump starting and shut off when the pump starts.

### 3.2 PAINTING

- A. Shop and field painting shall be specified by Owner.

### 3.3 FUNCTIONAL TEST

- A. Prior to Owner acceptance and formal pump station start-up, all equipment shall be inspected for proper alignment, quiet operation, proper connection, and satisfactory performance by means of a function test. A start-up report showing function testing, motor voltages, running amperages and well water levels shall be provided to the Engineer after pump station start-up.

**END OF SECTION**



## **SECTION 33 20 61 DISPOSAL OF DRILLING FLUIDS, CUTTINGS AND PUMPED WATER**

### **PART 1 - GENERAL**

#### **1.1 SECTION INCLUDES**

- A. Work to be performed under this Section includes the labor, supplies, tools, materials, and equipment necessary to dispose all water generated during well development.

#### **1.2 RELATED WORK**

- A. The Contractor shall comply with all applicable permits, laws, and regulations in disposing of water generated during well development. The permits, laws and regulations shall include, but not be limited to all federal, state, and local laws, regulations, and ordinances related to disposing of materials generated in constructing wells.

#### **1.3 REFERENCES**

- A. Utah Division of Water Quality Fact Sheet Regarding Water Discharge from Water Well Drilling and Operation

#### **1.4 SUBMITTALS**

- A. The Contractor shall submit the following:
  - 1. If applicable, or requested by the Engineer, approved chain-of-custody form(s) demonstrating compliance with federal, state, and local laws, regulations, and ordinances related to disposing of materials generated during well construction.

### **PART 2 - PRODUCTS**

#### **2.1 GENERAL**

- A. Provide all temporary and permanent materials, supplies, tools, equipment, and labor required to accomplish the work as specified.

#### **2.2 OWNER-SUPPLIED FACILITIES**

- A. The Owner will make available to the Contractor the use of an existing storm drain to directly discharge well development water and pump test water. The locations to discharge water are shown on Drawings. The Contractor is responsible for supplying the transmission piping and other appurtenances to convey the water from the well to the designated discharge point. The Contractor is responsible to ensure the discharge water meets all applicable water quality standards prior to discharge.

### **PART 3 - EXECUTION**

#### **3.1 DISCHARGE WATER FROM WELL RE-DEVELOPMENT PUMPING**

- A. All development water shall be contained onsite in appropriate containers, such as Baker tanks, Frac tanks, or equivalent until such time water quality suitable for discharge is achieved in accordance with State of Utah regulations.
- B. Solid matter will be separated from the drilling fluids and displacement fluids prior to disposal.
- C. The water remaining after separation that meets State of Utah water quality standards shall be discharged to the Owner-designated location. Any necessary storm drain discharge permits





shall be coordinated, obtained, and paid for by the Contractor.

- D. The dewatered solid matter remaining after separation shall be disposed of offsite by the Contractor.
- E. The water discharged from pump development and well testing shall be disposed via temporary pipelines provided by the Contractor. Well development and testing water shall be disposed of at the locations shown on Drawings. The Contractor shall discharge water so as not to create erosion or cause turbidity in any surface water channel.
- F. It is the Contractor's responsibility to prevent the discharge stream from damaging or eroding the site or any drainage channel.
- G. It is the Contractor's responsibility to minimize impacts to access and use of private and public road by the transmission piping and discharge stream. Use of ramps, earthen berms, or similar means for pipeline crossings of public and private accesses shall be employed. In addition, caution signs and speed restrictions shall be employed where public right-of-ways are impacted. The Contractor shall coordinate ramps and signage with the Owner.

**END OF SECTION**



# JORDAN VALLEY WATER CONSERVANCY DISTRICT DEEP WELL 6 UNDERGROUND WELL IMPROVEMENTS

8215 S 1300 W  
WEST JORDAN, UTAH 84088  
ISSUE DATE: JANUARY 2022

STATE OF UTAH

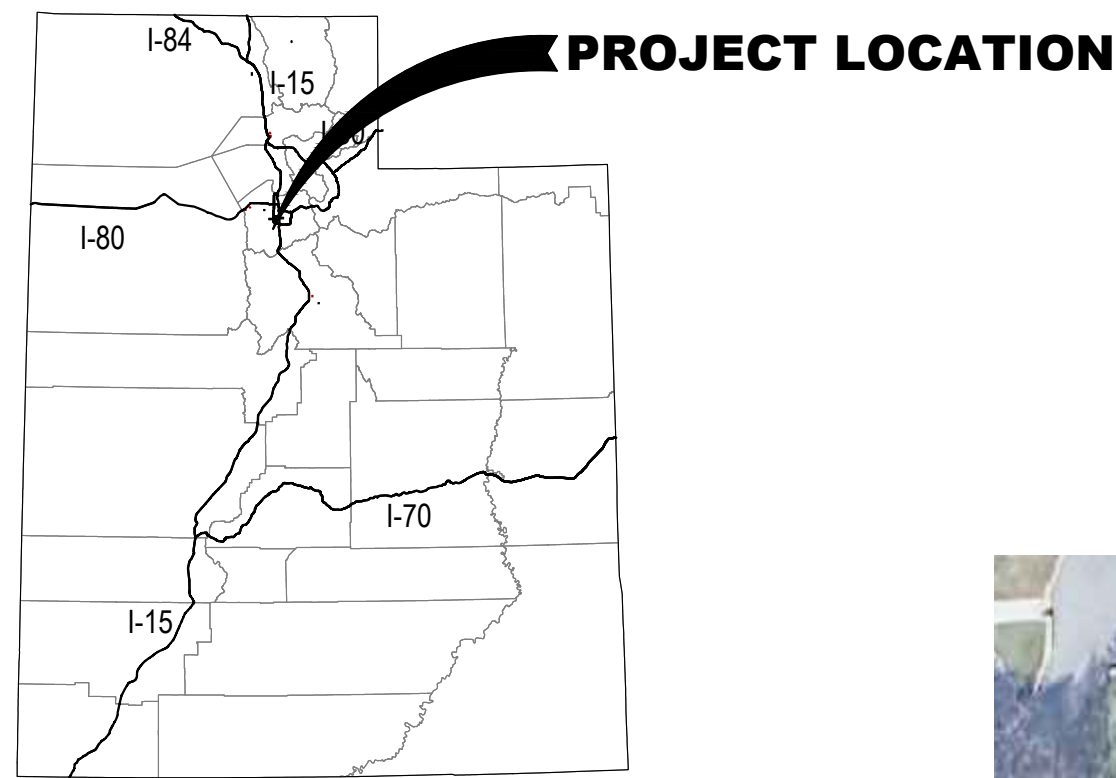

LEGEND

- MAJOR HIGHWAY
- COUNTY LINE

VICINITY MAP  
N.T.S.

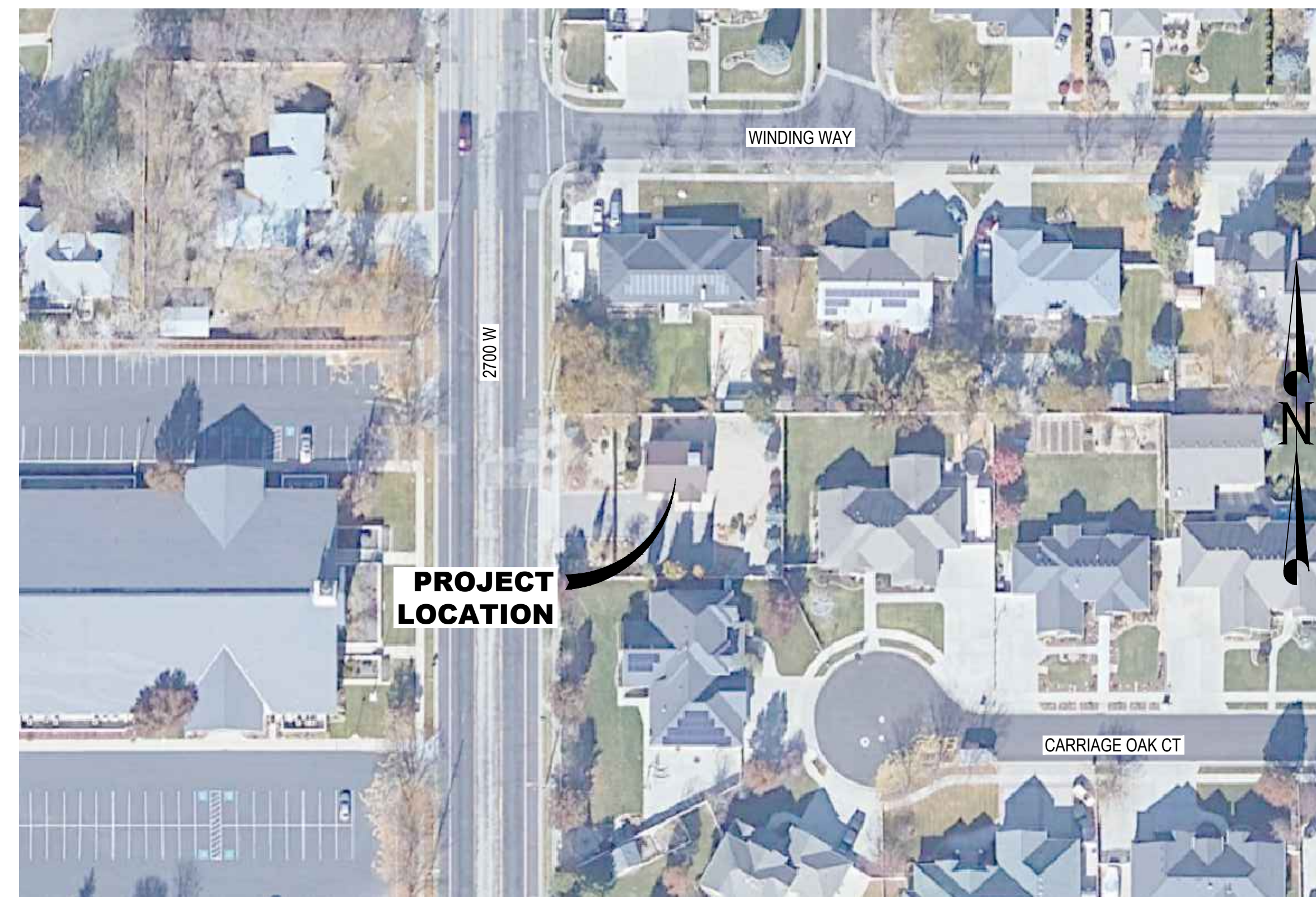

PROJECT VICINITY MAP  
N.T.S.

SHEET INDEX

SHEET NUMBER	SHEET TITLE	SHEET DESCRIPTION
1	G001	COVER SHEET
2	G002	GENERAL NOTES
3	S100	WELL SITE OVERVIEW
4	CU101	DEMOLITION PLAN
5	CU102	DEMOLITION SECTION & DETAILS
6	CU103	PRODUCT LUBE PIPING PLAN
7	CU104	PRODUCT LUBE PIPING SECTION & DETAILS
8	CU301	DW 6 WELL DIAGRAM

REV.#	BY	DATE	DESCRIPTION

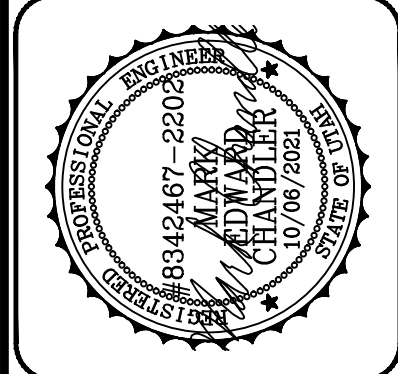

PROJECT MANAGER M. CHANDLER, P.E.	CHECKED BY	DRAWN BY C. HATCH	ISSUE DATE JANUARY 2022
--------------------------------------	------------	----------------------	----------------------------

**CRS ENGINEERS**  
Answers to Infrastructure®  
4246 S Riverboat Rd, Ste 200 | Salt Lake City, UT 84123 | P: 801.359.5565 | www.crsengineers.com

JORDAN VALLEY WATER CONSERVANCY DISTRICT  
DEEP WELL 6 UNDERGROUND WELL  
IMPROVEMENTS  
COVER SHEET

PROJECT NUMBER: 2020-0326	SHEET OF 1 OF 8	SHEET NUMBER: G001
------------------------------	--------------------	-----------------------



THE CONTRACTOR SHALL CAREFULLY READ ALL OF THE NOTES AND SPECIFICATIONS. THE CONTRACTOR SHALL BE SATISFIED AS TO THEIR TRUE MEANING AND INTENT AND SHALL BE RESPONSIBLE FOR COMPLYING WITH EACH.

**GENERAL NOTES:**

- 1) ALL IMPROVEMENTS SHALL BE CONSTRUCTED IN STRICT ACCORDANCE WITH ALL JURISDICTIONAL AUTHORITIES.
- 2) CONTRACTOR SHALL COMPLY WITH THE STANDARDS INDICATED ABOVE AND WITHIN THE CONSTRUCTION DOCUMENTS. THE CONTRACTOR SHALL NOTIFY ALL AGENCIES, OWNERS, ENGINEERS, AND UTILITY COMPANIES 5 DAYS PRIOR TO A PRE-CONSTRUCTION MEETING:

**OWNER:** JORDAN VALLEY WATER CONSERVANCY DISTRICT  
8215 S 1300 W  
WEST JORDAN, UTAH 84088  
PHONE: (801) 565-4300  
CONTACT: DAVID MCLEAN, P.E.

**ENGINEER:** CRS ENGINEERS  
4246 SOUTH RIVERBOAT ROAD, SUITE 200  
SALT LAKE CITY, UTAH 84123  
PHONE: (801) 359-5565  
FAX: (801) 359-4272  
CONTACT: MARK CHANDLER

- 3) IT IS INTENDED THAT THESE PLANS AND SPECIFICATIONS REQUIRE ALL LABOR AND MATERIALS NECESSARY AND PROPER FOR THE WORK CONTEMPLATED AND THAT THE WORK BE COMPLETED IN ACCORDANCE WITH THEIR TRUE INTENT AND PURPOSE. THE CONTRACTOR SHALL NOTIFY THE ENGINEER IMMEDIATELY REGARDING ANY DISCREPANCIES OR AMBIGUITIES WHICH MAY EXIST IN THE PLANS OR SPECIFICATIONS. THE ENGINEER'S INTERPRETATION THEREOF SHALL BE CONCLUSIVE.
- 4) WHERE THE PLANS OR SPECIFICATIONS DESCRIBE PORTIONS OF THE WORK IN GENERAL TERMS BUT NOT IN COMPLETE DETAIL, IT IS UNDERSTOOD THAT ONLY THE BEST GENERAL PRACTICE IS TO PREVAIL AND THAT ONLY MATERIALS AND WORKMANSHIP OF THE FIRST QUALITY ARE TO BE USED.
- 5) THE CONTRACTOR SHALL BE SKILLED AND REGULARLY ENGAGED IN THE GENERAL CLASS AND TYPE OF WORK CALLED FOR IN THE PROJECT PLANS AND SPECIFICATIONS. THEREFORE, THE OWNER IS RELYING UPON THE EXPERIENCE AND EXPERTISE OF THE CONTRACTOR, IT SHALL BE EXPECTED THAT PRICES PROVIDED WITHIN THE CONTRACT DOCUMENTS SHALL INCLUDE ALL LABOR AND MATERIALS NECESSARY AND PROPER FOR THE WORK CONTEMPLATED AND THAT THE WORK BE COMPLETED IN ACCORDANCE WITH THEIR TRUE INTENT AND PURPOSE.
- 6) THE CONTRACTOR SHALL BE COMPETENT, KNOWLEDGEABLE, AND HAVE SPECIAL SKILLS ON THE NATURE, EXTENT, AND INHERENT CONDITIONS OF THE WORK TO BE PERFORMED. CONTRACTOR SHALL ALSO ACKNOWLEDGE THAT THERE ARE CERTAIN PECULIAR AND INHERENT CONDITIONS EXISTENT IN CONSTRUCTION OF PARTICULAR FACILITIES, WHICH MAY CREATE, DURING THE CONSTRUCTION PROGRAM, UNUSUAL OR PECULIAR SAFETY CONDITIONS, WHICH CONDITIONS COULD BE HAZARDOUS TO PERSONS, PROPERTY AND THE ENVIRONMENT. CONTRACTOR SHALL BE AWARE OF SUCH PECULIAR RISKS AND HAVE THE SKILL AND EXPERIENCE TO FORESEE AND TO ADOPT PROTECTIVE MEASURES TO ADEQUATELY AND SAFELY PERFORM THE CONSTRUCTION WORK WITH RESPECT TO SUCH HAZARDS.
- 7) THE CONTRACTOR SHALL BE RESPONSIBLE FOR ALL PERMITS AND LICENSES REQUIRED FOR THE CONSTRUCTION AND COMPLETION OF THE PROJECT, AND SHALL PERFORM ALL WORK IN ACCORDANCE WITH THE REQUIREMENTS AND CONDITIONS OF ALL PERMITS AND APPROVALS APPLICABLE TO THIS PROJECT. THE CONTRACTOR SHALL ENSURE THAT THE NECESSARY RIGHTS-OF-WAY, EASEMENTS, AND/OR PERMITS ARE SECURED PRIOR TO CONSTRUCTION.
- 8) NOT USED
- 9) THE CONTRACTOR SHALL, AT THE TIME OF BIDDING, AND, THROUGHOUT THE PERIOD OF THE CONTRACT, BE LICENSED IN THE STATE OF UTAH AND SHALL BE BONDABLE FOR AN AMOUNT EQUAL TO OR GREATER THAN THE AMOUNT BID AND TO DO THE TYPE OF WORK CONTEMPLATED IN THE PLANS AND SPECIFICATIONS.
- 10) CONTRACTOR SHALL INSPECT THE SITE OF THE WORK PRIOR TO BIDDING TO SATISFY THEMSELVES BY PERSONAL EXAMINATION OR BY SUCH OTHER MEANS AS THEY MAY PREFER, OF THE LOCATION OF THE PROPOSED WORK, AND OF THE ACTUAL CONDITIONS OF, AND AT, THE SITE OF WORK. IF, DURING THE COURSE OF THEIR EXAMINATION, A BIDDER FINDS FACTS OR CONDITIONS WHICH APPEAR TO THEM TO BE IN CONFLICT WITH THE LETTER OR SPIRIT OF THE PROJECT PLANS AND SPECIFICATIONS, THEY SHALL CONTACT THE ENGINEER FOR ADDITIONAL INFORMATION AND EXPLANATION BEFORE SUBMITTING THEIR BID. SUBMISSION OF A BID BY THE CONTRACTOR SHALL CONSTITUTE ACKNOWLEDGMENT THAT, IF AWARDED THE CONTRACT, THEY HAVE RELIED AND ARE RELYING ON THEIR OWN EXAMINATION OF (1) THE SITE OF THE WORK, (2) ACCESS TO THE SITE, AND (3) ALL OTHER DATA AND MATTERS REQUISITE TO THE FULFILLMENT OF THE WORK AND ON THEIR OWN KNOWLEDGE OF EXISTING FACILITIES ON AND IN

THE VICINITY OF THE SITE OF THE WORK TO BE CONSTRUCTED UNDER THIS CONTRACT. THE INFORMATION PROVIDED BY THE OWNER OR THE ENGINEER IS NOT INTENDED TO BE A SUBSTITUTE FOR, OR A SUPPLEMENT TO THE INDEPENDENT VERIFICATION BY THE CONTRACTOR TO THE EXTENT SUCH INDEPENDENT INVESTIGATION OF SITE CONDITIONS IS DEEMED NECESSARY OR DESIRABLE BY THE CONTRACTOR. CONTRACTOR SHALL ACKNOWLEDGE THAT THEY HAVE NOT RELIED SOLELY UPON OWNER OR ENGINEER FURNISHED INFORMATION REGARDING SITE CONDITIONS IN PREPARING AND SUBMITTING THEIR BID.

- 11) THE CONTRACTOR SHALL BE RESPONSIBLE TO PROVIDE ALL WATER, POWER, SANITARY FACILITIES AND TELEPHONE SERVICES AS REQUIRED FOR THE CONTRACTORS USE DURING CONSTRUCTION.
- 12) THE CONTRACTOR SHALL BE HELD RESPONSIBLE FOR ANY FIELD CHANGES MADE WITHOUT PRIOR WRITTEN AUTHORIZATION FROM THE OWNER AND/OR ENGINEER.
- 13) THE CONTRACTOR AGREES THAT:
  - A) THEY SHALL BE RESPONSIBLE TO CLEAN THE JOB SITE AT THE END OF EACH DAY.
  - B) THEY SHALL BE RESPONSIBLE TO REMOVE AND DISPOSE OF ALL TRASH, SCRAP AND UNUSED MATERIAL AT THEIR OWN EXPENSE IN A TIMELY MANNER.
  - C) THEY SHALL BE RESPONSIBLE TO MAINTAIN THE SITE IN A NEAT, SAFE AND ORDERLY MANNER AT ALL TIMES.
  - D) THEY SHALL BE RESPONSIBLE TO KEEP MATERIALS, EQUIPMENT, AND TRASH OUT OF THE WAY OF OTHER CONTRACTORS SO AS NOT TO DELAY THE JOB. FAILURE TO DO SO WILL RESULT IN A DEDUCTION FOR THE COST OF CLEAN UP FROM THE FINAL PAYMENT.
  - E) THEY SHALL BE RESPONSIBLE FOR THEIR OWN SAFETY, TRAFFIC CONTROL, PERMITS, RETESTING AND RE-INSPECTIONS AT THEIR OWN EXPENSE.
- 16) THE CONTRACTOR SHALL ASSUME SOLE AND COMPLETE RESPONSIBILITY FOR JOBSITE CONDITIONS DURING THE COURSE OF CONSTRUCTION OF THIS PROJECT, INCLUDING SAFETY OF ALL PERSONS AND PROPERTY. THIS REQUIREMENT SHALL APPLY CONTINUOUSLY AND NOT BE LIMITED TO NORMAL WORKING HOURS. THE CONTRACTOR SHALL DEFEND, INDEMNIFY AND HOLD THE OWNER AND ENGINEER HARMLESS FROM ANY AND ALL LIABILITY, REAL OR ALLEGED, IN CONNECTION WITH THE PERFORMANCE OF WORK ON THIS PROJECT, EXCEPTING FOR LIABILITY ARISING FROM THE SOLE AND GROSS NEGLIGENCE OF THE OWNER OR THE ENGINEER.
- 17) THE CONTRACTOR SHALL BE RESPONSIBLE FOR ADEQUATELY SCHEDULING INSPECTION AND TESTING OF ALL FACILITIES CONSTRUCTED UNDER THIS CONTRACT. ALL TESTING SHALL CONFORM TO THE REGULATORY AGENCY'S STANDARD SPECIFICATIONS. ALL RE-TESTING AND/OR RE-INSPECTION SHALL BE PAID FOR BY THE CONTRACTOR.
- 18) IF EXISTING FEATURES NEED TO BE DISTURBED AND/OR REMOVED FOR THE PROPER PLACEMENT OF IMPROVEMENTS TO BE CONSTRUCTED BY THESE PLANS, THE CONTRACTOR SHALL BE RESPONSIBLE FOR PROTECTING EXISTING FEATURES FROM DAMAGE. COST OF REPLACING OR REPAIRING EXISTING FEATURES SHALL BE INCLUDED IN THE BID PRICE FOR ITEMS REQUIRING REMOVAL AND/OR REPLACEMENT.
- 19) THE CONTRACTOR SHALL MAINTAIN A NEATLY MARKED SET OF FULL-SIZE AS-BUILT DRAWINGS SHOWING THE FINAL LOCATION AND LAYOUT OF ALL FACILITIES. AS-BUILT DRAWINGS SHALL REFLECT CHANGE ORDERS, ACCOMMODATIONS, AND ADJUSTMENTS TO ALL IMPROVEMENTS CONSTRUCTED. WHERE NECESSARY, SUPPLEMENTAL DRAWINGS SHALL BE PREPARED AND SUBMITTED BY THE CONTRACTOR. PRIOR TO ACCEPTANCE OF THE PROJECT, THE CONTRACTOR SHALL DELIVER TO THE ENGINEER, ONE SET OF NEATLY MARKED AS-BUILT DRAWINGS SHOWING THE INFORMATION REQUIRED ABOVE. AS-BUILT DRAWINGS SHALL BE REVIEWED AND THE COMPLETE AS-BUILT DRAWING SET SHALL BE CURRENT WITH ALL CHANGES AND DEVIATIONS REDLINED AS A PRECONDITION TO THE FINAL PROGRESS PAYMENT APPROVAL AND/OR FINAL ACCEPTANCE.
- 20) NO ALLOWANCE WILL BE MADE FOR DISCREPANCIES OR OMISSIONS THAT CAN BE EASILY OBSERVED. VERIFY ALL EXISTING CONDITIONS BEFORE BIDDING, AND ANSWER ANY QUESTIONS BEFORE CONSTRUCTION.
- 21) FURNISH ALL MATERIALS TO COMPLETE THE PROJECT.
- 22) TRAFFIC CONTROL IS TO CONFORM TO THE CURRENT MUTCD AND UDOT STANDARDS.
- 23) CONTRACTOR SHALL BE RESPONSIBLE FOR ANY DAMAGE TO ADJACENT SURFACE IMPROVEMENTS.

**GENERAL CLEARING AND GRADING NOTES:**

- 1) THE CONTRACTOR IS RESPONSIBLE FOR MAINTAINING THE STREETS, STORM DRAINS, CHANNELS, DITCHES, AND SWALES FREE FROM DEBRIS, SOIL, MUD, OR OTHER MATERIAL THAT WOULD CAUSE A PUBLIC SAFETY CONCERN OR VIOLATE ANY CITY, STATE, OR FEDERAL LAWS.
- 2) BMP'S ARE TO BE IN PLACE AND MAINTAINED UNTIL WRITTEN NOTIFICATION IS RECEIVED FROM WEST JORDAN, UTAH.
- 3) IF DISTURBANCE OCCURS OUTSIDE THE LIMITS OF DISTURBANCE,

WORK WILL STOP AND REMAIN STOPPED UNTIL A WRITTEN RESPONSE IS RECEIVED FROM THE ENGINEER.

**GENERAL UTILITY NOTES:**

- 1) NO CHANGE IN DESIGN LOCATION OR GRADE WILL BE MADE BY THE CONTRACTOR WITHOUT THE WRITTEN APPROVAL OF THE PROJECT ENGINEER.

**ABBREVIATIONS**

APPROX	APPROXIMATE	LIN	LINEAR
ASTM	AMERICAN SOCIETY FOR TESTING AND MATERIALS	LP	LOW POINT
ANSI	AMERICAN NATIONAL STANDARDS INSTITUTE	MAX	MAXIMUM
APWA	AMERICAN PUBLIC WORKS ASSOCIATION	MEG	MATCH EXISTING GRADE
AWWA	AMERICAN WATER WORKS ASSOCIATION	MIN	MINIMUM
BF	BLIND FLANGE	MJ	MECHANICAL JOINT
BLDG	BUILDING	N	NORTH
C	CHORD LENGTH	NA	NOT APPLICABLE
C TO C	CENTER TO CENTER	NIC	NOT IN CONTACT
CB	CHORD BEARING	NO	NUMBER
CI	CAST IRON	NTS	NOT TO SCALE
CL	CLASS	OC	ON CENTER
CLR	CLEAR	OD	OUTSIDE DIAMETER
CMP	CORRUGATED METAL PIPE	OSHA	OCCUPATIONAL SAFETY & HEALTH ADMINISTRATION
CO	CLEANOUT	PE	PLAIN END
CONC	CONCRETE	PG	PAGE
DI	DUCTILE IRON	PI	POINT OF INTERSECTION
DI	DIMENSION	PJDI	PUSH-ON JOINT
DI	DIMENSION	PSF	POUNDS PER FOOT
E	EAST	PSI	POUNDS PER SQUARE INCH
EA	EDGE OF ASPHALT	PUE	PUBLIC UTILITY
EG	EXISTING GRADE	PVC	EASEMENT
EL	ELEVATION	RCP	POLYVINYL CHLORIDE REINFORCED CONCRETE PIPE
ELEV	ELEVATION	R	RADIUS
EP	EDGE OF PAVEMENT	RT	RIGHT
EW	EACH WAY	RJ	RESTRAINED JOINT
EX	EXISTING	S	SOUTH
FG	FINISH GRADE	SEC	SECTION
FH	FIRE HYDRANT	SS	SANITARY SEWER
FL	FLOWLINE	STA	STATION
FLG	FLANGE	T	TOP
FT	FEET	TB	THRUST BLOCK
HOPE	HIGH DENSITY POLYETHYLENE PIPE	TBA	TO BE ABANDONED
HORIZ	HORIZONTAL	TBC	TOP BACK CURB
HP	HIGH POINT	TC	TOP OF CONCRETE
ID	INSIDE DIAMETER	TYP	TYPICAL
IE	INVERT ELEVATION	UDOT	UTAH DEPARTMENT OF TRANSPORTATION
INV	INVERT	VERT	VERTICAL
IR	IRON ROD	W	WATER
IRR	IRRIGATION	W	WEST
LT	LEFT	W	WITH
L	LENGTH	WWF	WELDED WIRE FABRIC
LBS	POUNDS		
L.F.	LINEAR FEET		

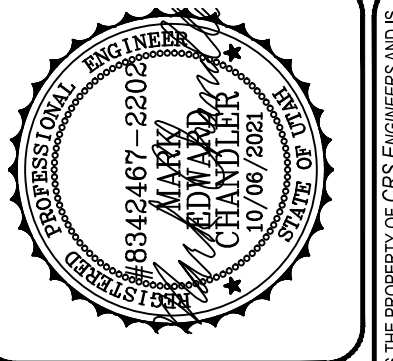

**CRS ENGINEERS**  
Answers to Infrastructure®  
4246 S Riverboat Rd, Ste 200 | Salt Lake City, UT 84123 | P: 801.359.5565 | www.crsengineers.com

JORDAN VALLEY WATER CONSERVANCY DISTRICT  
**DEEP WELL 6 UNDERGROUND WELL IMPROVEMENTS**  
GENERAL NOTES

PROJECT NUMBER: 2020-0326	SHEET OF 2 OF 8	SHEET NUMBER: G002
------------------------------	--------------------	-----------------------

DESCRIPTION	DATE	REV#	BY	CHECKED BY	DRAWN BY	ISSUE DATE
				M. CHANDLER, P.E.	C. HATCH	JANUARY 2022

IF THE SCALE OR A LETTER DOES NOT MEASURE, INCH IN LENGTH, DO NOT USE THE INFORMATION CONTAINED IN THE DRAWINGS AS THE BASIS FOR ANY PROJECT OR ACTION OF THIS PROJECT EXCEPT BY AGREEMENT WITH CRS ENGINEERS.





2700 W

EXISTING STORM DRAIN DISCHARGE  
FOR PUMPED DEVELOPMENT WATER

ROOF HATCH TO  
ACCESS WELL HEAD

JWVCD DEEP WELL 6

EXISTING COLUMN,  
TUBE, SHAFT, AND PUMP  
ASSEMBLY CURRENTLY  
STORED HERE

LOCKING GATE

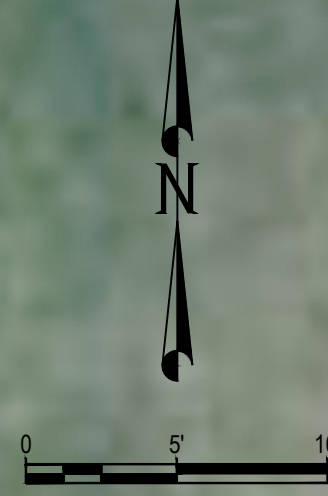

PROJECT NUMBER:  
2020-0326  
SHEET OF  
3 OF 8  
SHEET NUMBER:  
**S100**

JORDAN VALLEY WATER CONSERVANCY DISTRICT  
**DEEP WELL 6 UNDERGROUND WELL  
IMPROVEMENTS**  
WELL SITE OVERVIEW

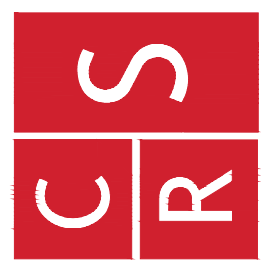

**CRS ENGINEERS**  
Answers to Infrastructure®  
4246 S Riverboat Rd, Ste 200 | Salt Lake City, UT 84123 | P: 801.359.5565 | www.crsengineers.com

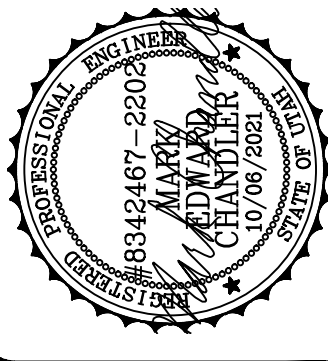

REV.#	BY	DATE	DESCRIPTION

PROJECT MANAGER M. CHANDLER, P.E.	CHECKED BY	DRAWN BY C. HATCH	ISSUE DATE JANUARY 2022
--------------------------------------	------------	----------------------	----------------------------

IF THE SCALE BAR AT LEFT DOES NOT MEASURE INCH IN LENGTH, DO NOT USE. THE DIMENSIONS SHOWN IN THIS DRAWING ARE THE PROPERTY OF CRS ENGINEERS AND IS NOT BE LOANED, REPRODUCED, COPIED, OR TRANSMITTED IN ANY FORM OR BY ANY MEANS, ELECTRONIC OR MECHANICAL, WITHOUT THE WRITTEN PERMISSION OF CRS ENGINEERS. PROJECT EXCEPT BY AGREEMENT WITH CRS ENGINEERS.



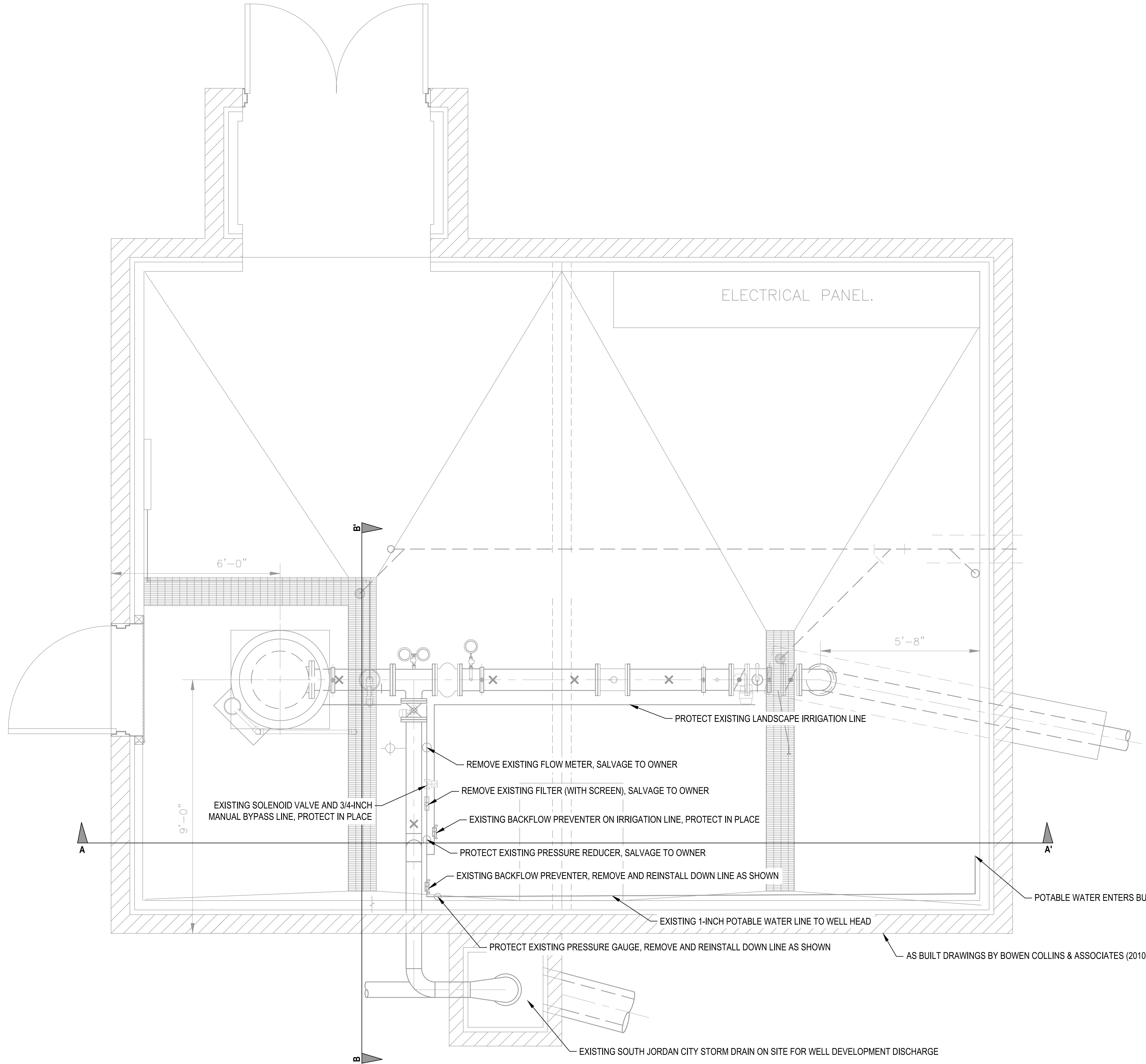

PROJECT NUMBER:  
2020-0326  
SHEET OF  
4 OF 8  
SHEET NUMBER:  
**CU101**

JORDAN VALLEY WATER CONSERVANCY DISTRICT  
**DEEP WELL 6 UNDERGROUND WELL IMPROVEMENTS**  
DEMOLITION PLAN

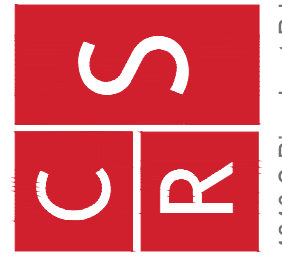

**CRS ENGINEERS**  
Answers to Infrastructure®  
4246 S Riverboat Rd, Ste 200 | Salt Lake City, UT 84123 | P: 801.359.5565 | www.crsengineers.com



REV.#	BY	DATE	DESCRIPTION

PROJECT MANAGER  
M. CHANDLER, P.E.

CHECKED BY  
C. HATCH

DRAWN BY  
C. HATCH

ISSUE DATE  
JANUARY 2022

IF THE SCALE BAR AT LEFT DOES NOT MEASURE 1 INCH IN LENGTH, DO NOT USE. ALL DIMENSIONS SHOWN IN THIS DRAWING ARE THE PROPERTY OF CRS ENGINEERS AND IS NOT BE USED FOR ANY OTHER PROJECT OR CONTRACTOR OF THIS PROJECT EXCEPT BY AGREEMENT WITH CRS ENGINEERS. SPECIFIED IN THE DRAWING TAKE PRECEDENCE TO SCALED MEASUREMENTS.

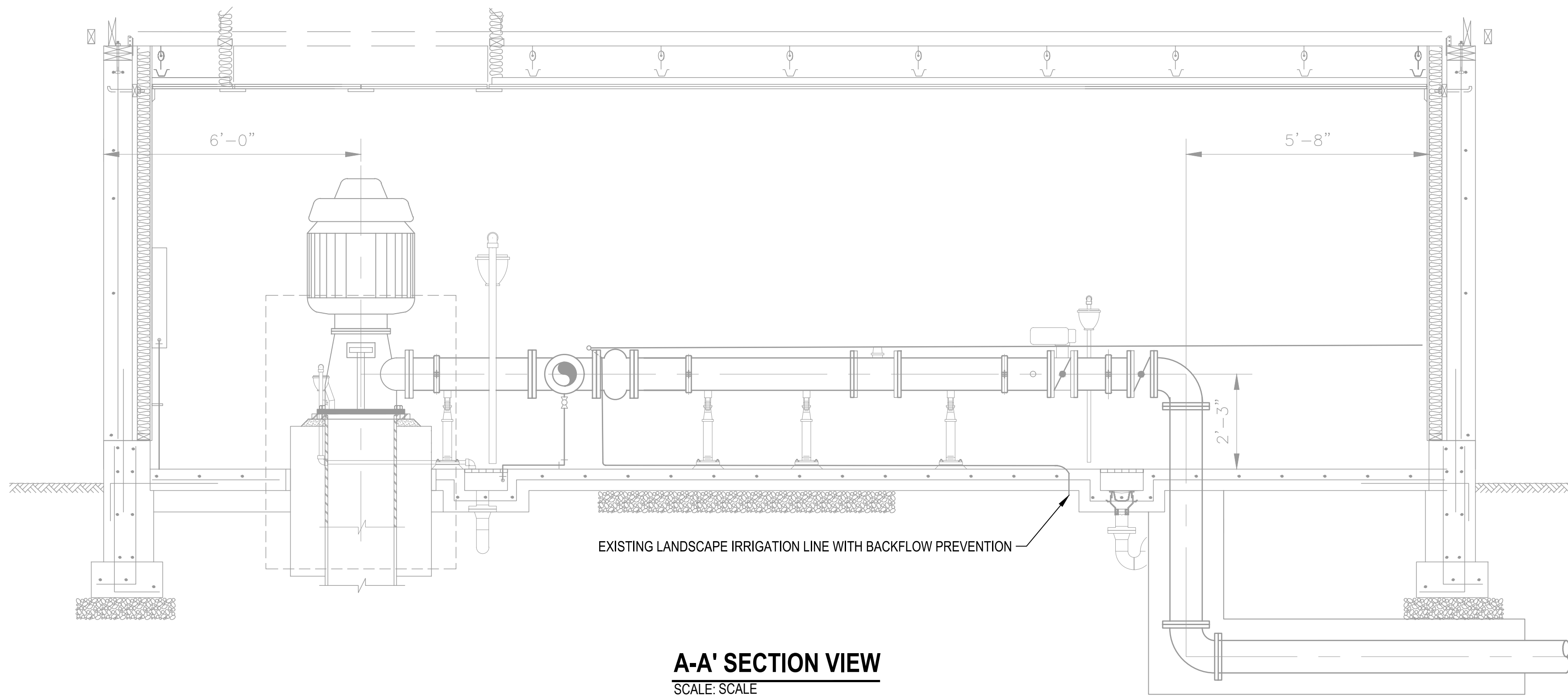

**A-A' SECTION VIEW**  
SCALE: SCALE

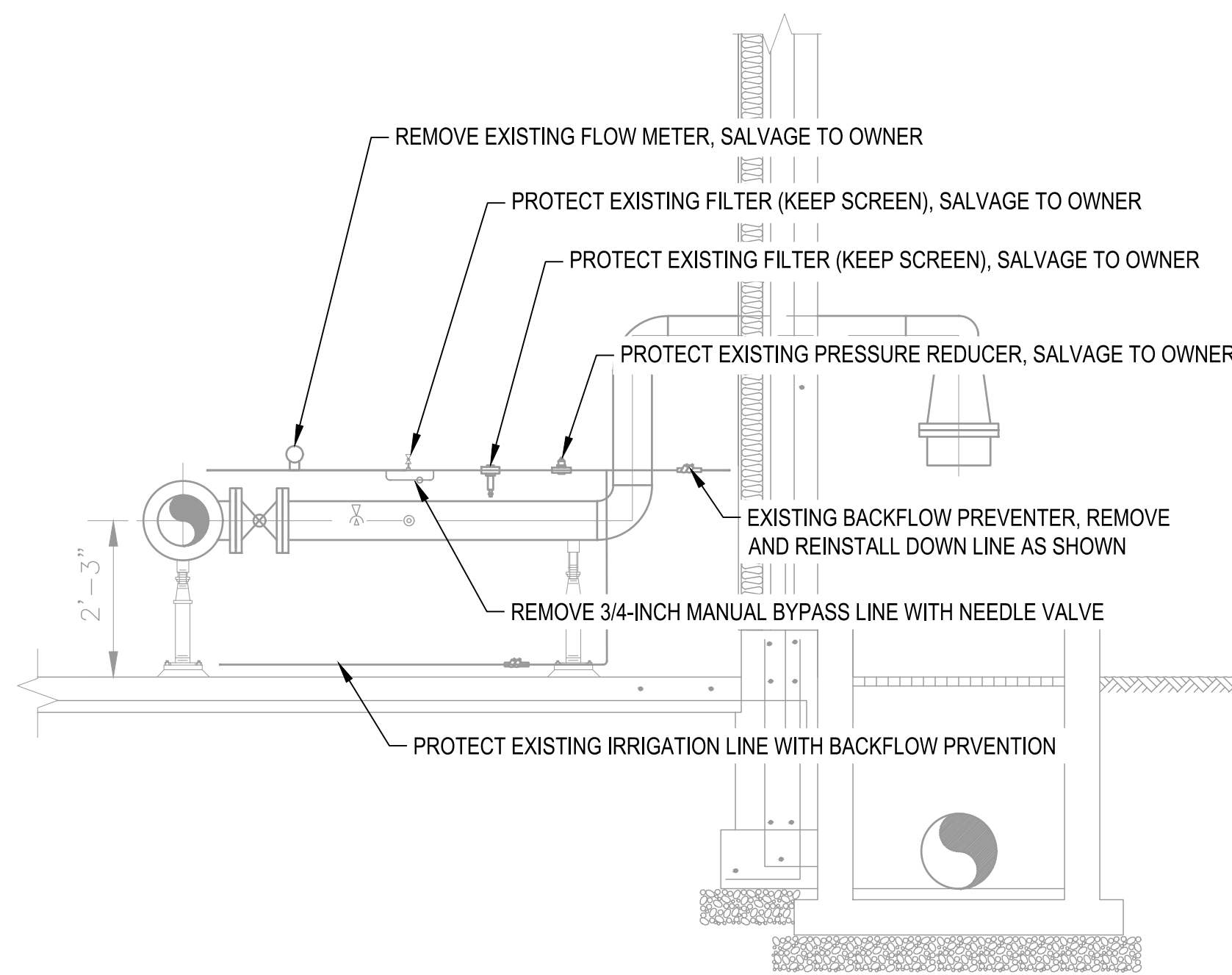

**B-B' SECTION VIEW**  
SCALE: SCALE

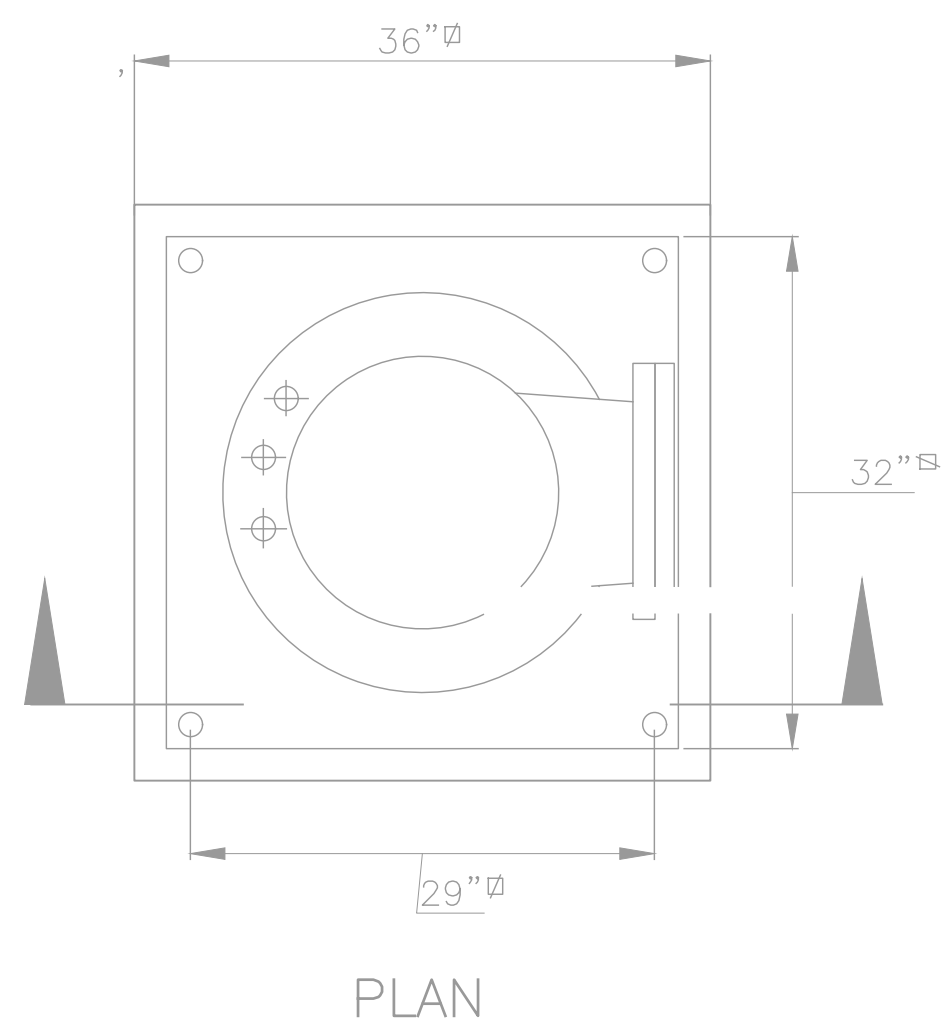

PLAN

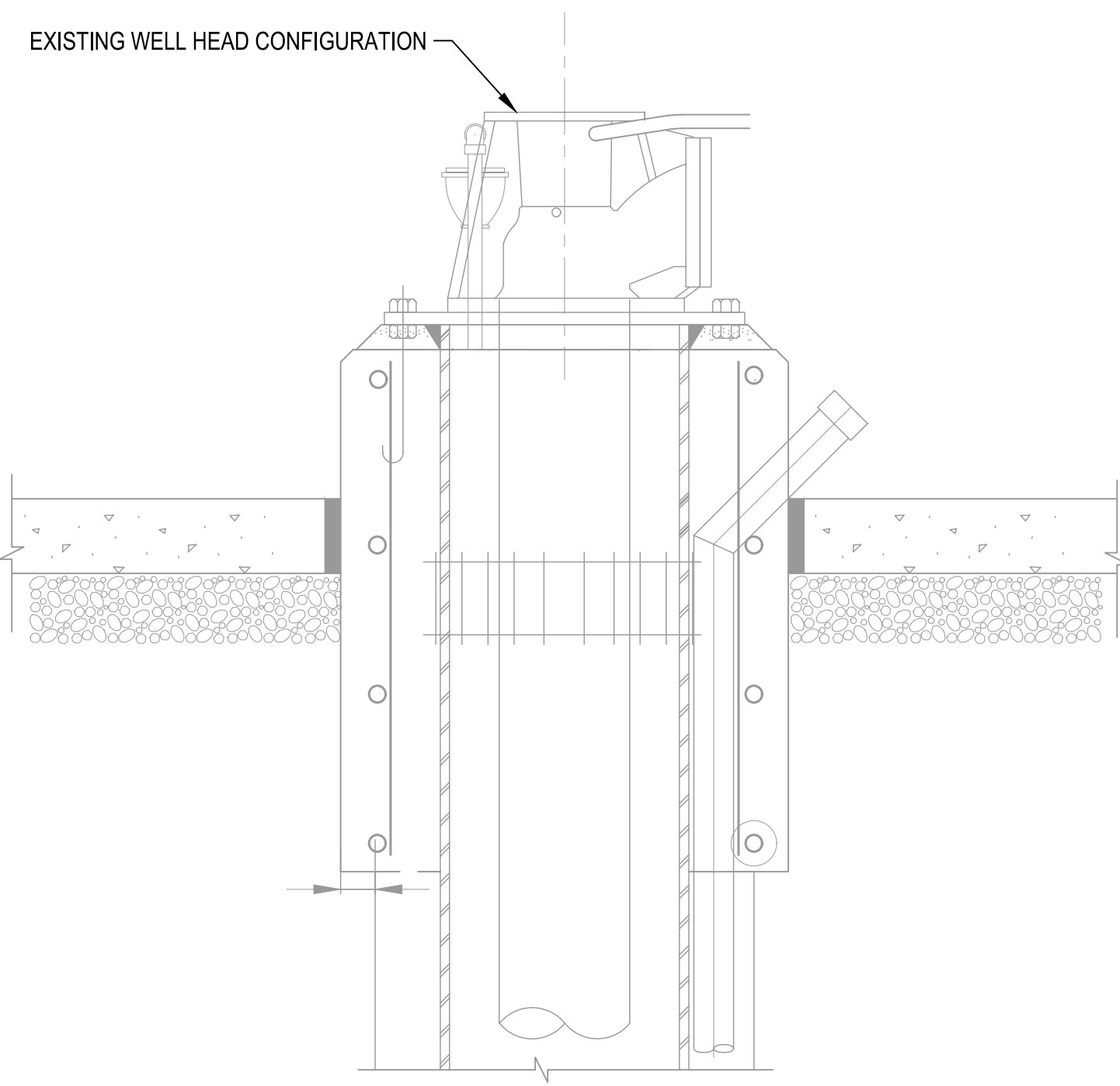

SECTION

**DW 6 WELLHEAD CONFIGURATION**  
SCALE: NONE

REV.#	BY	DATE	DESCRIPTION

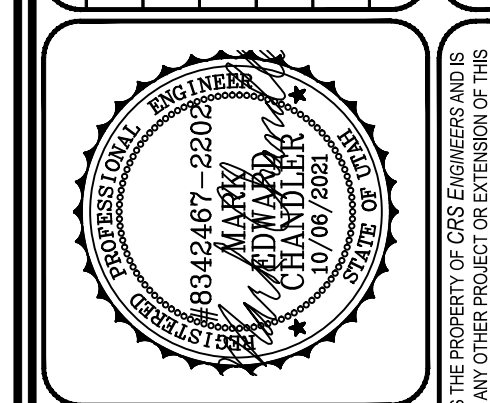

**CRS ENGINEERS**  
Answers to Infrastructure®

4246 S Riverboat Rd, Ste 200 | Salt Lake City, UT 84123 | P: 801.359.5565 | www.crsengineers.com

THE INFORMATION CONTAINED IN THESE DRAWINGS IS THE PROPERTY OF CRS ENGINEERS AND IS NOT TO BE REPRODUCED OR TRANSMITTED IN ANY FORM OR BY ANY MEANS, ELECTRONIC OR MECHANICAL, INCLUDING PHOTOCOPYING, RECORDING, OR BY ANY INFORMATION STORAGE AND RETRIEVAL SYSTEM, WITHOUT THE WRITTEN PERMISSION OF CRS ENGINEERS. PROJECT EXCEPT BY AGREEMENT WITH CRS ENGINEERS.

JORDAN VALLEY WATER CONSERVANCY DISTRICT  
**DEEP WELL 6 UNDERGROUND WELL IMPROVEMENTS**  
DEMOLITION SECTION & DETAILS

PROJECT NUMBER: 2020-0326	SHEET OF 5 OF 8	SHEET NUMBER: <b>CU102</b>
------------------------------	--------------------	-------------------------------

PROJECT MANAGER M. CHANDLER, P.E.	CHECKED BY C. HATCH	DRAWN BY C. HATCH	ISSUE DATE JANUARY 2022
--------------------------------------	------------------------	----------------------	----------------------------

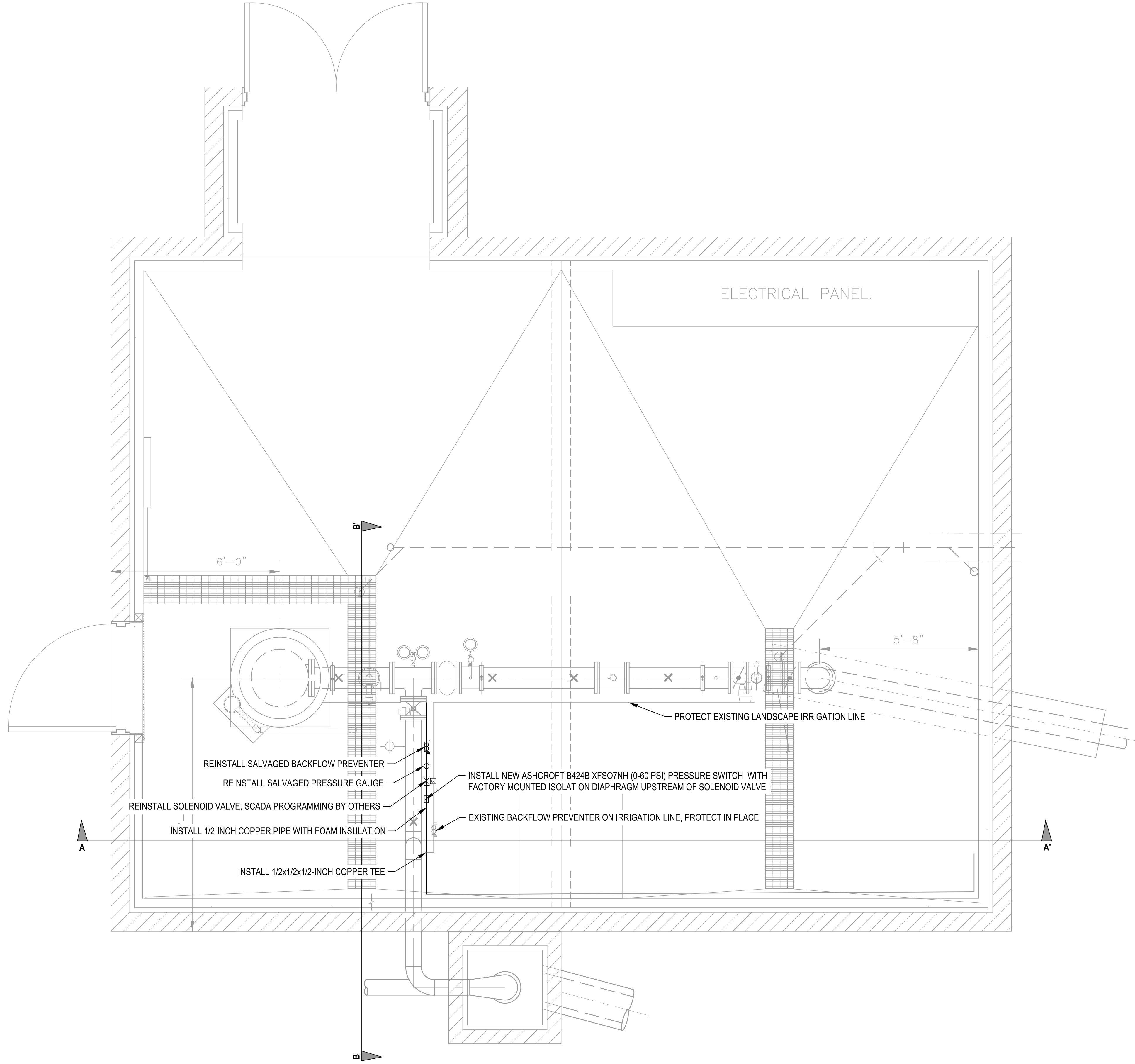

PROJECT NUMBER:  
2020-0326  
SHEET OF  
6 OF 8  
SHEET NUMBER:  
**CU103**

JORDAN VALLEY WATER CONSERVANCY DISTRICT  
**DEEP WELL 6 UNDERGROUND WELL IMPROVEMENTS**  
PRODUCT LUBE PIPING PLAN

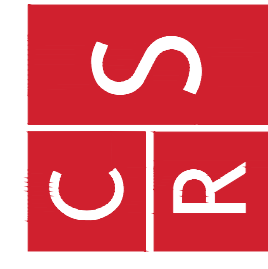

**CRS ENGINEERS**  
Answers to Infrastructure®

4246 S Riverboat Rd, Ste 200 | Salt Lake City, UT 84123 | P: 801.359.5565 | www.crsengineers.com

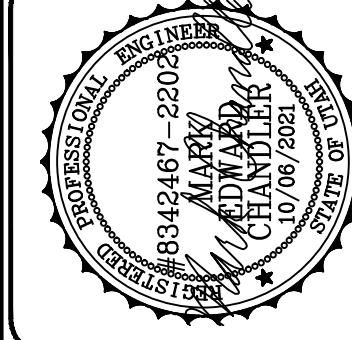

THE INFORMATION CONTAINED IN THIS DRAWING IS THE PROPERTY OF CRS ENGINEERS AND IS NOT TO BE REPRODUCED OR TRANSMITTED IN ANY FORM OR BY ANY MEANS, ELECTRONIC OR MECHANICAL, WITHOUT THE WRITTEN PERMISSION OF CRS ENGINEERS. PROJECT EXCEPT BY AGREEMENT WITH CRS ENGINEERS.

REV.#	BY	DATE	DESCRIPTION

  

PROJECT MANAGER M. CHANDLER, P.E.	CHECKED BY	DRAWN BY C. HATCH	ISSUE DATE JANUARY 2022
--------------------------------------	------------	----------------------	----------------------------



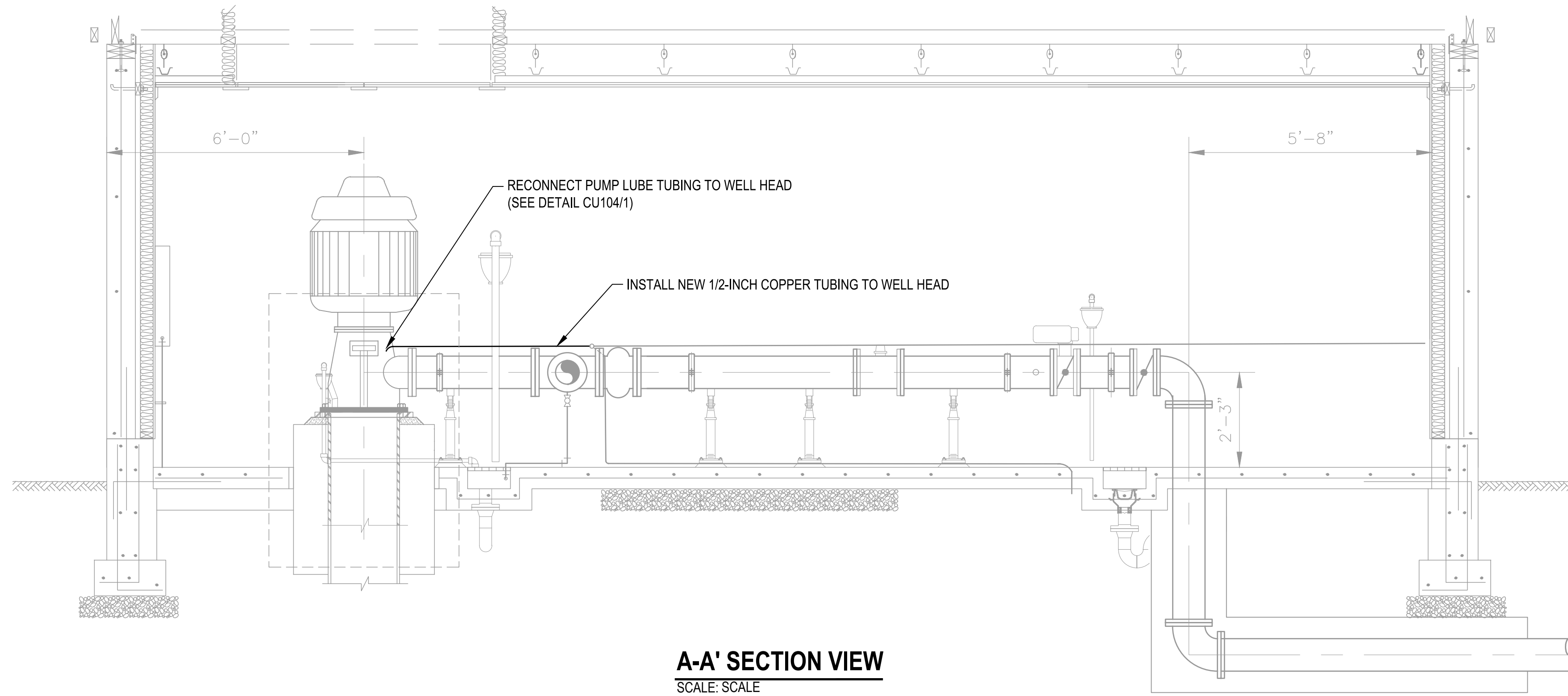

**A-A' SECTION VIEW**  
SCALE: SCALE

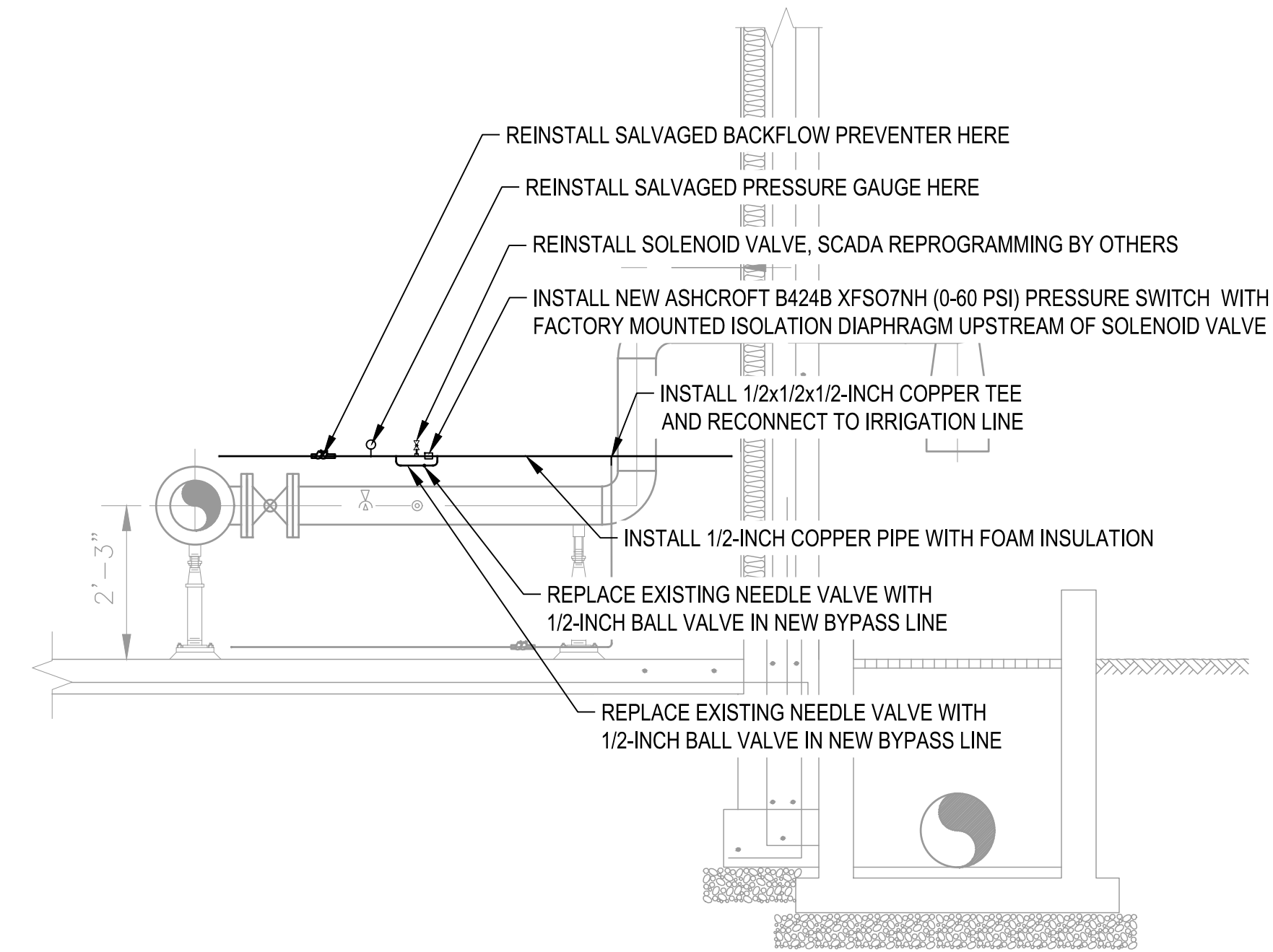

**B-B' SECTION VIEW**  
SCALE: SCALE

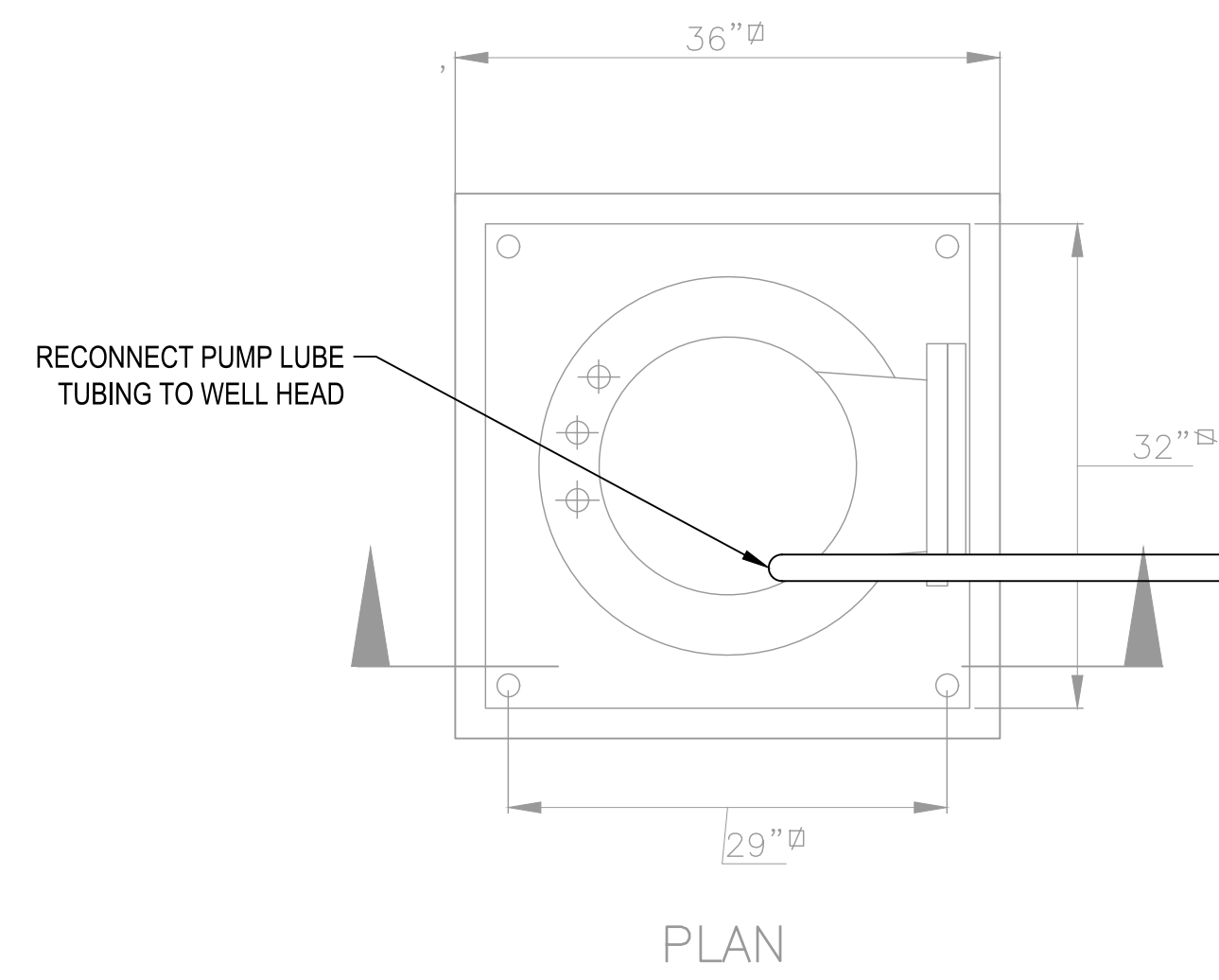

PLAN

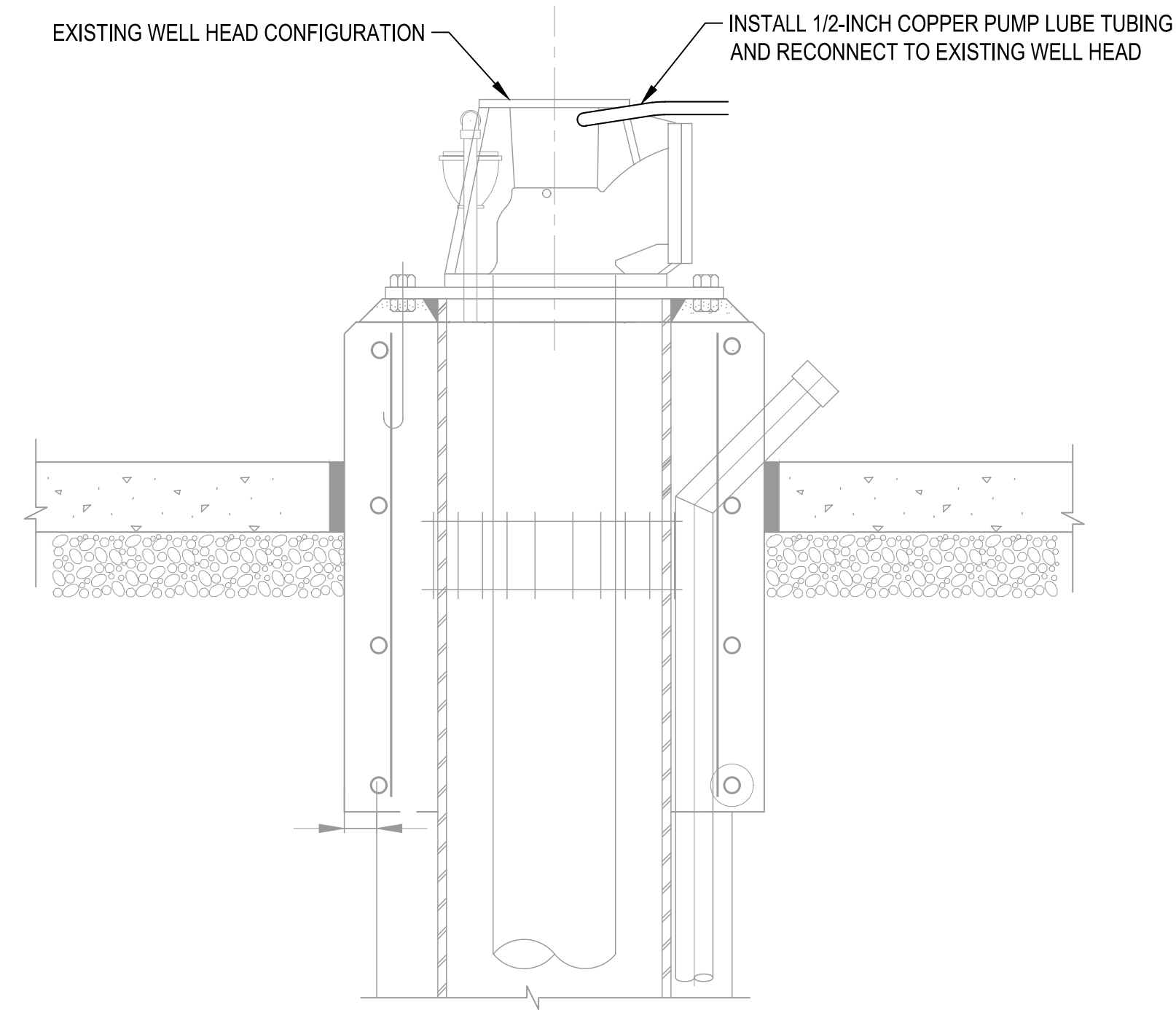

SECTION

**CU104 DW 6 WELLHEAD CONFIGURATION**  
SCALE: NONE

REV.#	BY	DATE	DESCRIPTION

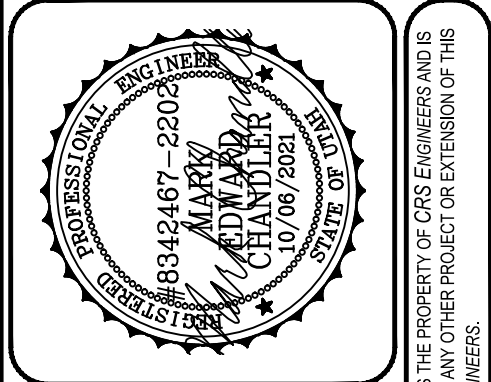

**CRS ENGINEERS**  
Answers to Infrastructure®

4246 S Riverboat Rd, Ste 200 | Salt Lake City, UT 84123 | P: 801.359.5565 | www.crsengineers.com

IF THE SCALE BAR AT LEFT DOES NOT MEASURE, INCH IN LENGTH, DO NOT USE. THE INFORMATION CONTAINED IN THESE DRAWINGS IS THE PROPERTY OF CRS ENGINEERS AND IS NOT BE LOANED, REPRODUCED, COPIED, REPRODUCED, OR TRANSMITTED IN ANY FORM OR BY ANY MEANS, WITHOUT THE WRITTEN PERMISSION OF CRS ENGINEERS. PROJECT EXCEPT BY AGREEMENT WITH CRS ENGINEERS.

JORDAN VALLEY WATER CONSERVANCY DISTRICT  
**DEEP WELL 6 UNDERGROUND WELL IMPROVEMENTS**  
PRODUCT LUBE PIPING SECTION & DETAILS

PROJECT NUMBER: 2020-0326	SHEET OF 7 OF 8	SHEET NUMBER: <b>CU104</b>
------------------------------	--------------------	-------------------------------



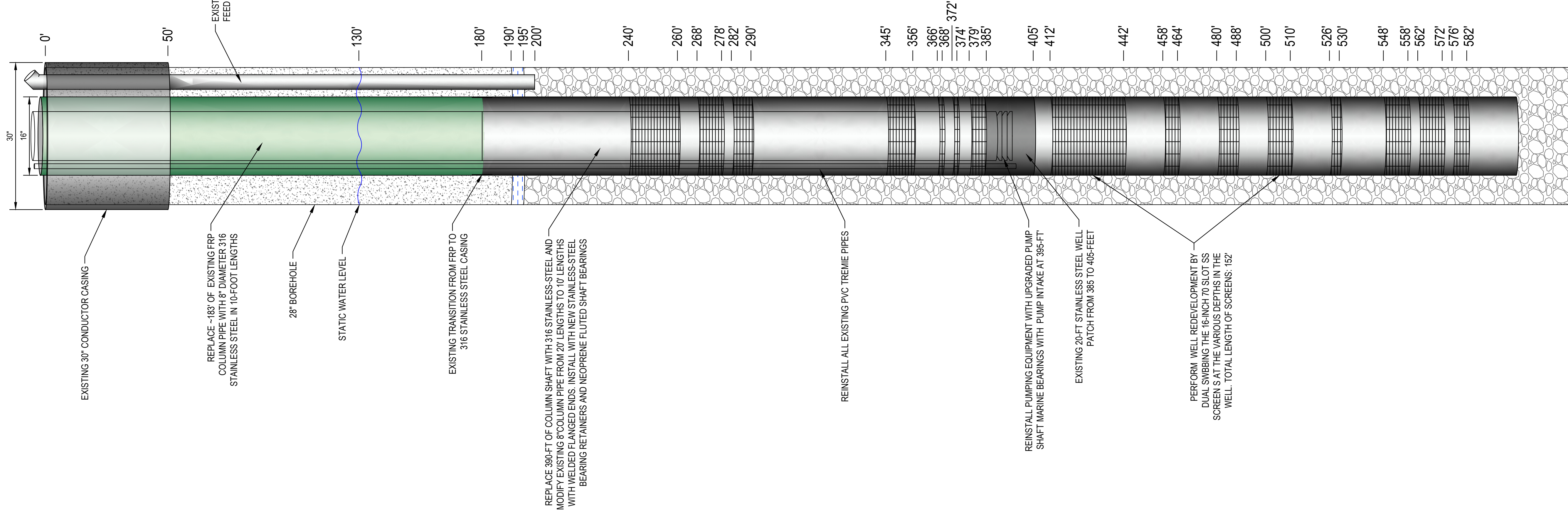

PROJECT MANAGER M. CHANDLER, P.E.	CHECKED BY	DRAWN BY C. HATCH	ISSUE DATE JANUARY 2022
--------------------------------------	------------	----------------------	----------------------------



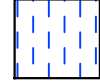
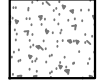

SCREEN DEPTH	SCREEN LENGTH
240-260 FEET	20 FEET
266-278 FEET	10 FEET
282-290 FEET	8 FEET
345-356 FEET	11 FEET
366-368 FEET	2 FEET
372-374 FEET	2 FEET
379-394 FEET	15 FEET
412-442 FEET	30 FEET
458-464 FEET	6 FEET
480-488 FEET	8 FEET
500-510 FEET	10 FEET
526-530 FEET	4 FEET
548-558 FEET	10 FEET
562-572 FEET	10 FEET
576-582 FEET	6 FEET
<b>TOTAL SCREEN:</b>	<b>152 FEET OF SCREEN</b>

**LEGEND**

-  6X9 GRAVEL PACK
-  BENTONITE SEAL
-  NEAT CEMENT SURFACE SEAL
-  0 SLOT CLOSED WRAP SCREEN
-  16-INCH 70 SLOT SS SCREEN
-  16-INCH FRP CASING

PROJECT NUMBER:  
2020-0326

SHEET OF  
8 8

SHEET NUMBER:  
**CU301**

**JORDAN VALLEY WATER CONSERVANCY DISTRICT  
DEEP WELL 6 UNDERGROUND WELL  
IMPROVEMENTS  
DW 6 WELL DIAGRAM**

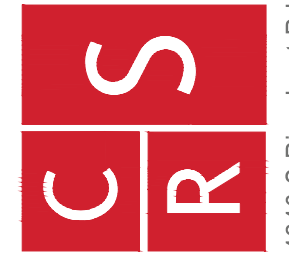

**CRS ENGINEERS**  
Answers to Infrastructure®

4246 S Riverboat Rd, Ste 200 | Salt Lake City, UT 84123 | P: 801.359.5565 | www.crsengineers.com

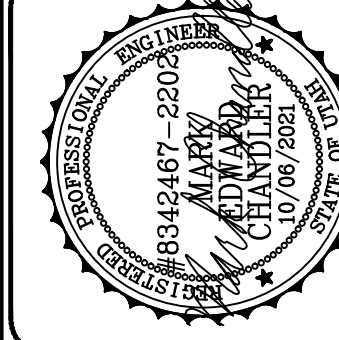

REV.#	BY	DATE	DESCRIPTION

PROJECT MANAGER  
M. CHANDLER, P.E.

CHECKED BY  
C. HATCH

DRAWN BY  
C. HATCH

ISSUE DATE  
JANUARY 2022

IF THE SCALE BAR LET DOES NOT MEASURE, INCH IN LENGTH, DO NOT USE IT. THE INFORMATION CONTAINED IN THIS DRAWING IS THE PROPERTY OF CRS ENGINEERS AND IS NOT TO BE REPRODUCED OR TRANSMITTED IN ANY FORM OR BY ANY MEANS, ELECTRONIC OR MECHANICAL, WITHOUT THE WRITTEN PERMISSION OF CRS ENGINEERS. PROJECT EXCEPT BY AGREEMENT WITH CRS ENGINEERS.